

LED Type Wafer Alignment Sensor

HD-T1 SERIES



HD-T1 SERIES



The use of a safe LED light beam now allows for high precision detection with a resolution of 30 μm **1.181 mil**

No safety measures are required at all

As a safe red LED is used as the light source, there is no need for time-consuming safety measures. The protective covers usually required when using laser beams are not needed, and FDA approval is not required in order to use this sensor in the US.

Easy installation

This unit is equipped with a one-touch connector to connect the sensor head to the controller. The amount of wiring is therefore minimized, resulting in easy maintenance.

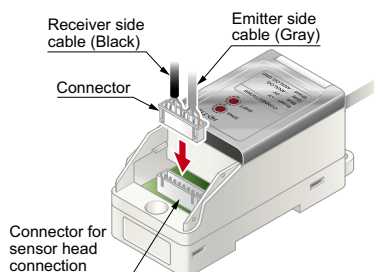

Low current consumption of 70 mA or less

The HD-T1 series has a maximum current consumption of only 70 mA, for both the sensor head and the controller. The current consumption is almost as low as that of photoelectric sensors.

High resolution of 30 μm 1.181 mil

Although the HD-T1 series uses a red LED for its light source, it has the same high level of performance as laser sensors, thus enabling high precision detection.

No need for beam axis alignment

As both the receiver and the emitter are integrated into a single unit, there is no need to perform any troublesome alignment of the beam axis. In addition, as the HD-T1 series can perform its detection function over a broad area - with both a sensing range and a sensing width of 30 mm **1.181 in**, this unit can be utilized for sensing wafers of many different sizes.

Adjustment functions for both span and shift have been incorporated

In addition to the span adjustment function, a convenient shift adjustment function has also been incorporated into the analog output (1 to 5 V). The shift adjustment function allows the analog voltage to be shifted by up to ± 0.5 V.

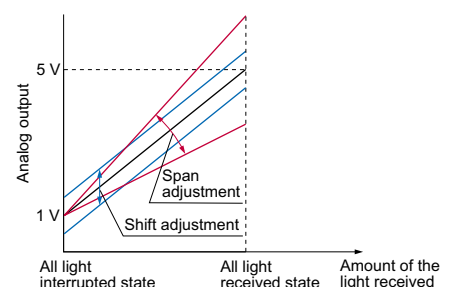

APPLICATIONS

Detecting wafer eccentricities or notches



ORDER GUIDE

Sensor head

Appearance	Sensing range	Sensing width	Model No.
	30 mm 1.181 in (fixed) (Note)	30 mm 1.181 in	HD-T1030

Note: The value is in a state that the sensor is mounted on the mounting base at the time of factory shipment.

Controller

Appearance	Model No.	Output
	HD-T1C	Analog voltage • Output voltage: 1 to 5 V

Make sure to use the sensor head and the controller together as a set.

SPECIFICATIONS

Sensor head

Model No.		HD-T1030
Item		HD-T1030
CE marking directive compliance		EMC Directive, RoHS Directive
Applicable controller		HD-T1C
Sensing width		30 mm 1.181 in (Linearity is specified at 28 mm 1.102 in width.)
Sensing range		30 mm 1.181 in (fixed) (Note 2)
Environmental resistance	Pollution degree	3 (Industrial environment)
	Protection	IP40 (IEC)
	Ambient temperature	0 to +40 °C +32 to +104 °F (No dew condensation), Storage: -20 to +55 °C -4 to +131 °F
	Ambient humidity	35 to 85 % RH, Storage: 35 to 85 % RH
	Ambient illuminance	Incandescent light: 3,000 lx or less at the light-receiving face, Fluorescent light: 3,000 lx or less at the light-receiving face
	Voltage withstandability	1,000 V AC for one min. between all supply terminals connected together and enclosure
	Insulation resistance	20 MΩ, or more, with 250 V DC megger between all supply terminals connected together and enclosure
	Vibration resistance	10 to 150 Hz frequency, 0.75 mm 0.030 in double amplitude in X, Y and Z directions for two hours each
	Shock resistance	490 m/s ² acceleration (50 G approx.) in X, Y and Z directions three times each
Emitting element		Red LED (Peak emission wavelength: 650 nm 0.026 mil)
Receiving element		Photodiode
Material		Enclosure: PEI, Front cover: Glass, Mounting base: Aluminum
Cable		Heat-resistant PVC cable, 0.5 m 1.640 ft long, with a connector at the end
Weight		Net weight: 150 g approx.

Notes: 1) Where measurement conditions have not been specified precisely, the conditions used were an ambient temperature of +20 °C **+68 °F**.

2) The value is in a state that the sensor is mounted on the mounting base at the time of factory shipment.

SPECIFICATIONS

Controller

Item	Model No.	HD-T1C
CE marking directive compliance		EMC Directive, RoHS Directive
Applicable sensor head		HD-T1030
Supply voltage		24 V DC $\pm 10\%$ Ripple P-P 10 % or less
Current consumption		70 mA or less (Including sensor head)
Analog output		Analog voltage <ul style="list-style-type: none"> • Output voltage: 1 ± 0.5 V (all light interrupted) to 5 ± 0.5 V (all light received) • Output impedance: 75Ω
	Response time	0.5 ms or less (8 V/ms or more)
	Resolution	$30 \mu\text{m}$ 1.181 mil (Note 2)
	Linearity	$\pm 1.0\%$ F.S. (at 28 mm 1.102 in sensing width of the sensing center) (Note 3)
	Temperature characteristics	$\pm 0.1\%$ F.S./ $^{\circ}\text{C}$ (at $24 \pm 2^{\circ}\text{C}$ 75.2 $\pm 35.6^{\circ}\text{F}$) (Note 3)
Span adjustment function		Span of the analog output voltage is adjusted. 15-turn endless adjuster
Shift adjustment function		Offset of the analog output voltage is adjusted. 15-turn endless adjuster
Warming-up period		30 min. or more
Environmental resistance	Pollution degree	3 (Industrial environment)
	Protection	IP40 (IEC)
	Ambient temperature	0 to $+40^{\circ}\text{C}$ +32 to +104 $^{\circ}\text{F}$ (No dew condensation), Storage: -20 to $+70^{\circ}\text{C}$ -4 to +158 $^{\circ}\text{F}$
	Ambient humidity	35 to 85 % RH, Storage: 35 to 85 % RH
	Voltage withstandability	1,000 V AC for one min. between all supply terminals connected together and enclosure
	Insulation resistance	20 M Ω , or more, with 250 V DC megger between all supply terminals connected together and enclosure
	Vibration resistance	10 to 150 Hz frequency, 0.75 mm 0.030 in double amplitude in X, Y and Z directions for two hours each
	Shock resistance	490 m/s ² acceleration (50 G approx.) in X, Y and Z directions three times each
Material		Enclosure: Heat-resistant ABS, Connector cover: Heat-resistant ABS, Adjuster cover: Polycarbonate
Cable		0.22 mm ² 3-core heat-resistant PVC cable, 0.3 m 0.984 ft long
Cable extension		Extension up to total 3 m 9.843 ft is possible with 0.3 mm ² , or more, heat-resistant PVC cable.
Weight		Net weight: 85 g approx.

Notes: 1) Where measurement conditions have not been specified precisely, the conditions used were an ambient temperature of $+20^{\circ}\text{C}$ **+68 $^{\circ}\text{F}$** .

2) Resolution refers to the peak to peak distance conversion value of analog output (in the frequency band below 20 MHz).

3) This is the representative example of measurement with a combination of sensor head and controller.

I/O CIRCUIT AND WIRING DIAGRAMS (Controller)

I/O circuit diagram

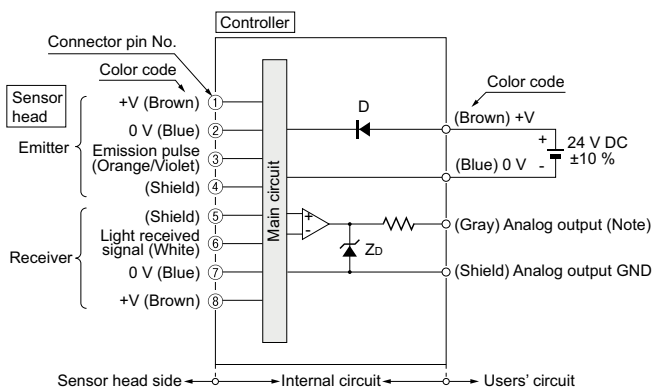

Terminal arrangement

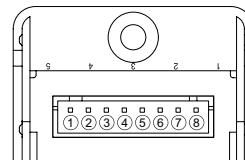

Terminal No.	Description	
①	+V	Emitter side
②	0 V	
③	Emission pulse	
④	Shield	
⑤	Shield	Receiver side
⑥	Light received signal	
⑦	0 V	
⑧	+V	

Note: Analog output does not incorporate a short-circuit protection circuit.
Do not connect it directly to a power supply or a capacity load.

Symbols ... D : Reverse supply polarity protection diode
ZD: Surge absorption zener diode

PRECAUTIONS FOR PROPER USE



- Never use this product as a sensing device for personnel protection.
- In case of using sensing devices for personnel protection, use products which meet laws and standards, such as OSHA, ANSI or IEC etc., for personnel protection applicable in each region or country.

- Make sure to use the sensor head and the controller together as a set.

Mounting

Sensor head

- Mount the sensor head using 2 pcs. M4 hexagon-socket-head bolts (purchase separately) with a tightening torque of 0.5 N·m or less.
- Do not remove the screws fixing the emitter / receiver and the mounting base. If removed, the output value will change.
- Do not fix with the screws, using the mounting hole on the side of emitter / receiver.

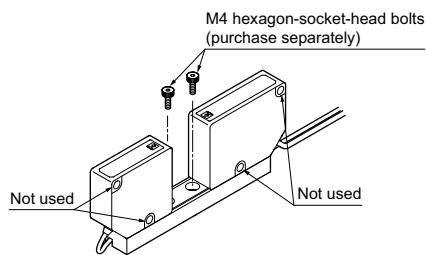

Controller

<In case of using DIN rail>

- ① Fit the front part of the mounting section of the unit on the 35 mm 1.378 in width DIN rail, pressing the stopper towards the arrow (the stopper is locked) shown in the right figure.
 - ② Press down the rear part of the mounting section of the unit on the 35 mm 1.378 in width DIN rail to fit it.
- * For removal, insert a flat-bladed screwdriver into the groove of the stopper and pull the handle backwards.

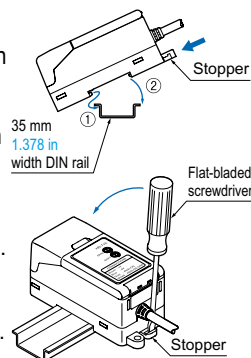

<In case of using screws>

- Mount using M4 pan head screws with a tightening torque of 1.2 N·m or less.

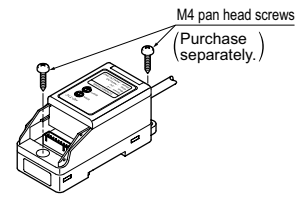

Wiring

- Analog output of controller does not incorporate a short-circuit protection circuit. Do not connect it directly to a power supply or a capacity load.
- Care should be taken that static electricity is not applied to the connector during wiring. It may damage the product.
- Take care that wrong wiring will damage the product.
- Cable extension is possible up to total 3 m 9.843 ft with 0.3 mm², or more, cable. Note that the cable length of the sensor head cannot be changed.
- Do not apply stress such as forced bending and pulling to the cable joint.
- Make sure to use an isolation transformer for the DC power supply. If an autotransformer (single winding transformer) is used, this product or the power supply may get damaged.
- In case a surge is generated in the used power supply, connect a surge absorber to the supply and absorb the surge.

Others

- Do not use during the initial transient time (0.5 sec. approx.) after the power supply is switched on.
- This product outputs according to the amount of LED light received. Optical power varies between the center and the periphery of sensing range, and note that dimensional accuracy cannot be assured.
- Do not allow any water, oil, fingerprints, etc., which may refract light, or dust, dirt, etc., which may block light, to stick to the emitting/receiving surfaces of the sensor head. In case they are present, wipe them with a clean, dust-free soft cloth or lens paper.
- If the sensing object is specular or transparent object, note that accurate measurement may not be possible.

DIMENSIONS (Unit: mm in)

The CAD data can be downloaded from our website.

HD-T1030

Sensor head

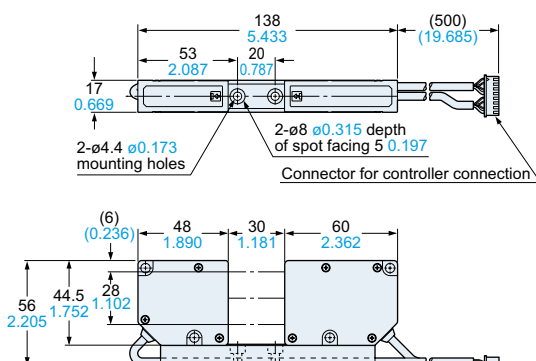

HD-T1C

Controller

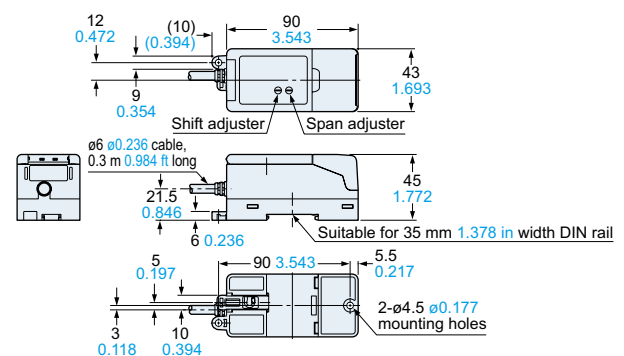

<When the cover is removed>

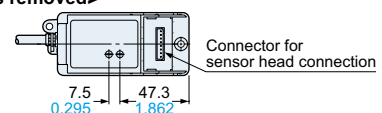

Disclaimer

The applications described in the catalog are all intended for examples only. The purchase of our products described in the catalog shall not be regarded as granting of a license to use our products in the described applications. We do NOT warrant that we have obtained some intellectual properties, such as patent rights, with respect to such applications, or that the described applications may not infringe any intellectual property rights, such as patent rights, of a third party.

Panasonic
INDUSTRY

Panasonic Industry Co., Ltd.

Industrial Device Business Division
7-1-1, Morofuku, Daito-shi, Osaka 574-0044, Japan
industrial.panasonic.com/ac/e/