

IGBT BASED DC SOLID STATE RELAY

- ▶ Latest IGBT technology generation.
- ▶ Ultra low drop out voltage at on-state (low power losses).
- ▶ Built-in protection against overvoltage and fasts transients bursts.
- ▶ Built-in protection against shorts-circuits of the load.
- ▶ Built-in over-temperature protection.
- ▶ Pluggable control connector with spring terminals

SDI1001700



Nominal Control voltage	24&48VDC
Nominal. output voltage	750VDC
Nom. load current with heatsink	100ADC

Load voltage range	Load current range	Control input voltage	Supply voltage range	Visualizations	Dimensions (WxHxD)	Weight
12 to 940VDC	0 à 100A (with heatsink)	24-48VDC	24-48VDC	3 LEDs : -SUPPLY (Green) -STATUS (Orange) -FAULT (Red)	157 x 68 x 83 (mm)	1050g

Fig. 1

INTERNAL DIAGRAM

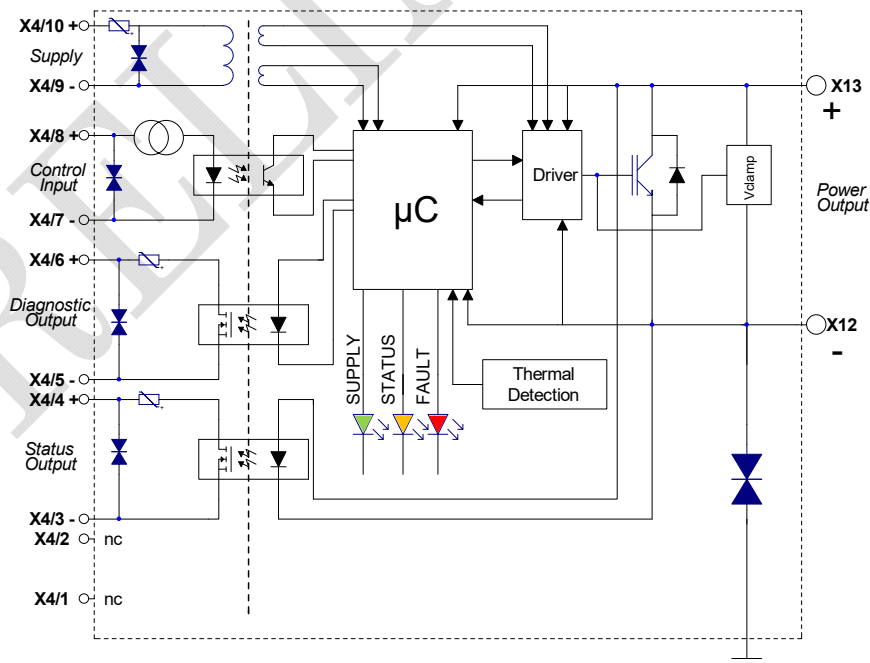

Proud to serve you

Fig. 2

EXAMPLES OF WIRING DIAGRAM

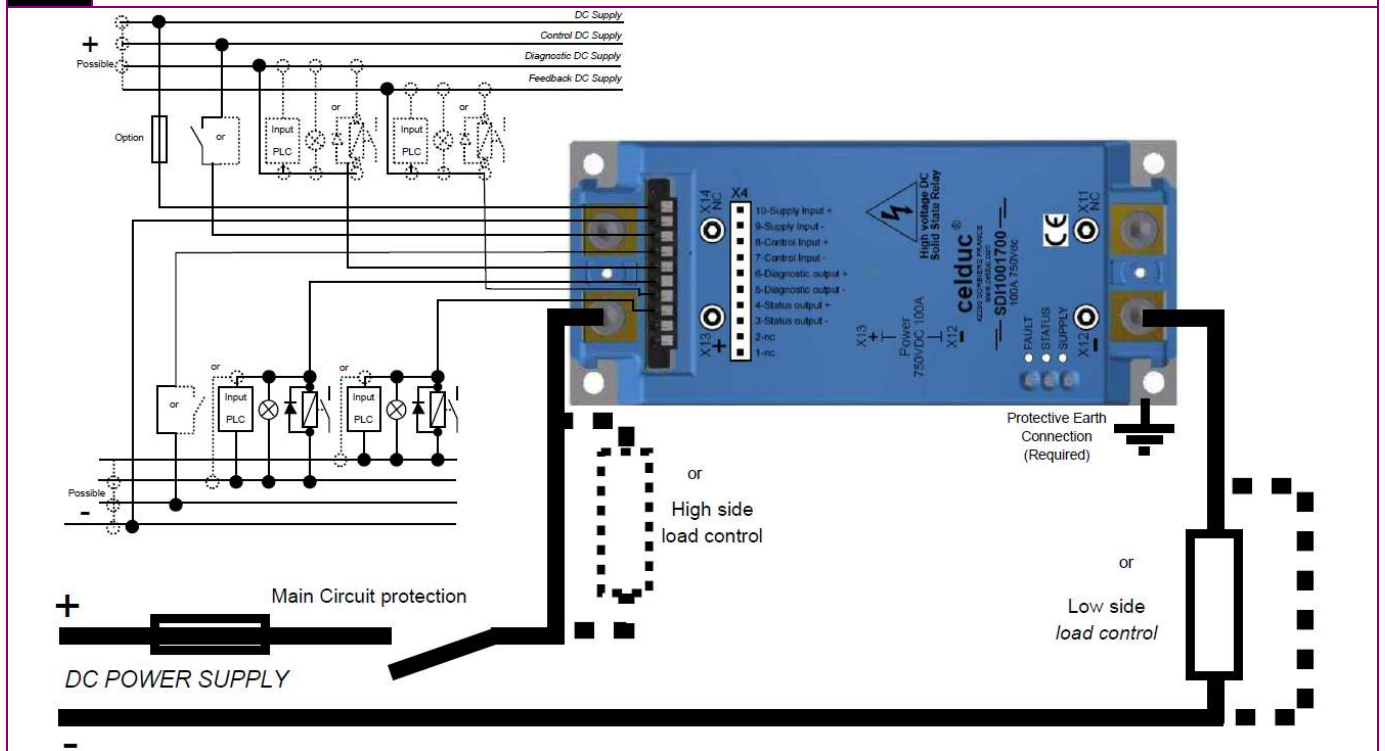

SUPPLY INPUT

	CHARACTERISTIC	LABEL	VALUE	INFO.
SUPPLY CIRCUIT	Marking		X4/10 & X4/9	
	Nom. supply voltage	Us	24 & 48Vdc	
	Min. supply voltage	Us min	16.8Vdc	
	Max. supply voltage	Us max	60Vdc	
	Max. peak voltage	Usp	67.2Vdc	@pulse<1s
	Typ. operating current	Is	<100mA	
	Max. reverse current	-Is	<1µA	
	Overvoltage protection		Transient voltage suppressor	
	Internal Overcurrent and shorts-circuits protection		Thermistor	
	Reverse polarity protection		YES	
	Under Voltage Lockout protection UVLO		YES	

Proud to serve you

CONTROL INPUT

INPUT CIRCUIT	CHARACTERISTIC	LABEL	VALUE	INFO.
	Marking		X4/8 & X4/7	
	Control voltage range	Uc	24 & 48Vdc	
	Current consumption	Ic	<5mA	See fig. 3
	Max. reverse current	-Ic	<1μA	
	Min. switch-on voltage	Uc_on_min	14.4V	
	Min. releasing voltage	Uc_off_min	4Vdc	
	Max. input voltage	Ucmax	60Vdc	
	Max. reverse voltage	-Ucmax	60Vdc	
Input impedance	Re	Current limitation		

Fig. 3

CONTROL INPUT CHARACTERISTICS

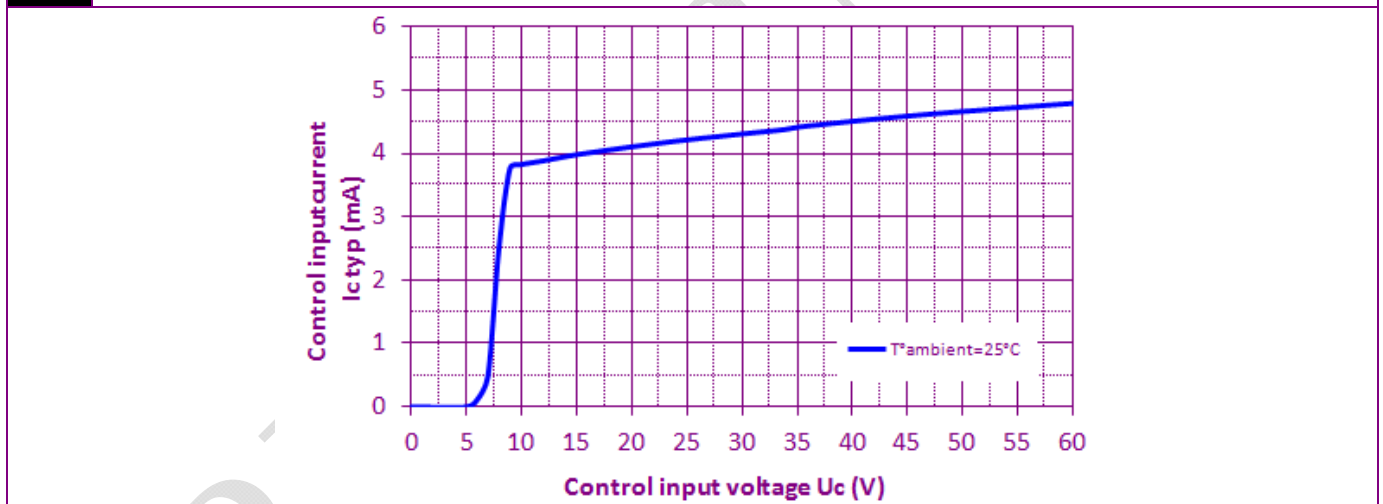

Proud to serve you

Data given at T_{ambient}=40°C and subject to modification without previous notice

POWER OUTPUT

CHARACTERISTIC	LABEL	VALUE	INFO.
Nom. power voltage	Ue	750Vdc	
Min. power voltage	Uemin	12Vdc	
Max permanent voltage	Umax1	940Vdc	
Non-permanent voltage	Umax2	1000Vdc	@pulse<5min
Repetitive peak voltage	Umax3	1270V	@pulse<20ms
Max. nominal currents	Ice	100A	See fig. 4 Values with heatsink
Min. nominal currents	Ice min	0.1A	
Non-repetitive IGBT peak overload current	Icepeak	330A	See fig. 8
Max. leakage current	Icelk	15µA	
On-state voltage	VCEsat	1.38V	See fig. 5 @Ie=100A Tj=125°C
Reverse voltage (internal diode)	-Ut	1.22V	See fig. 6 @Ie=100A Tj=125°C
Max. inductive load (load + line length)		1mH	See fig. 9 @Ie=100A Tjmax=125°C
Overvoltage protection		Activ Clamp Protection	
Shorts-circuits/Overload protection		Automatic Desaturation detection	
Nominal desaturation current detection	Ice desat	225A	@Tj=25°C
Min Desaturation detection time		7µs	
Max. single pulse avalanche energy	Eep	20J	@tpulse=1ms
Max. repetitive pulse avalanche energy	Eep	7J	@Ie=100A
Typ. output capacitance	Cout	1.65nf	@Uc=0
IGBT junction/case thermal resistance	Rthjc	0.054K/W	See fig. 7
Reverse diode junction/case thermal resistance	Rthjc	0.11K/W	See fig. 7
Built-in heatsink thermal resistance vertically mounted	Rthra	2.4K/W	@ΔTra=65°C
Heatsink thermal time constant	Tthra	30min	@ΔTra=65°C
Maximum junction temperature	Tjmax	105°C	@Ie=100A
Storage temperature	Tstg	-40->+85°C	
Operating temperature	Tamb	-40->+70°C	
Ambient humidity	Hr	5 à 95%	

Proud to serve you

Fig. 4

POWER DISSIPATION AND LOAD CURRENT LIMIT VS TEMPERATURE

Please refer to the installation notice for precautions about mounting the device on a heatsink.

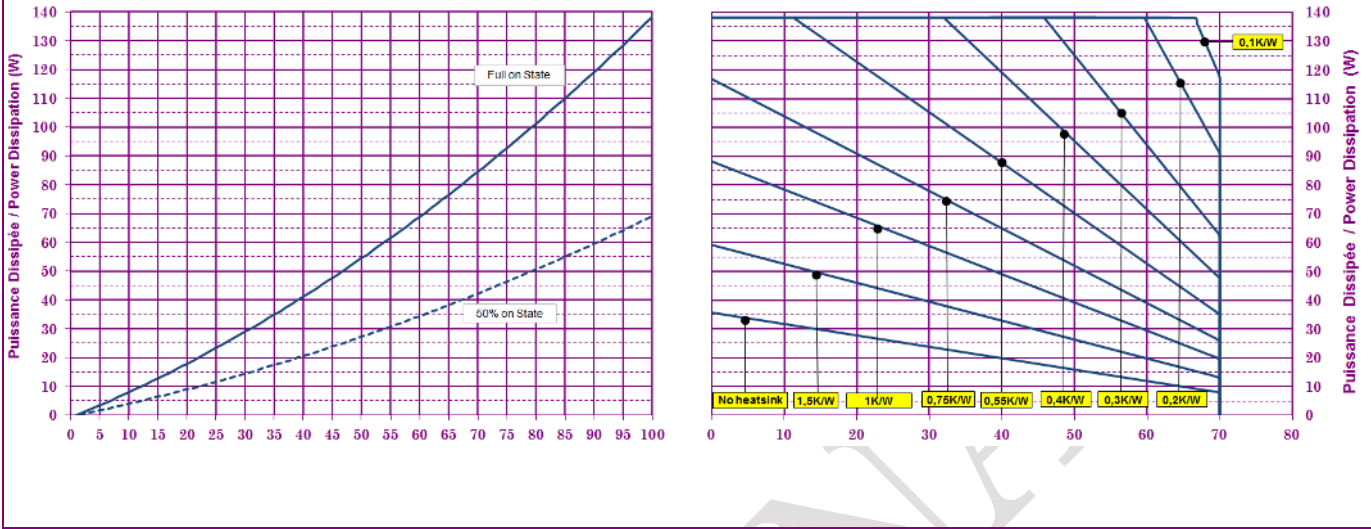

Fig. 5

IGBT DROP OUT VOLTAGE

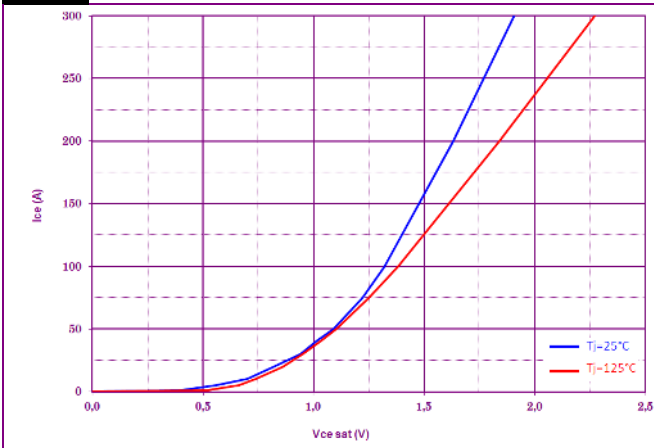

Fig. 6

REVERSE DIODE DROP OUT VOLTAGE

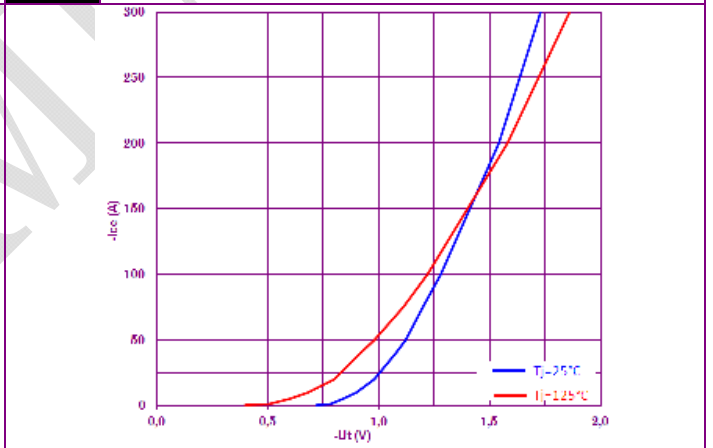

Fig. 7

POWER ELEMENT TRANSIENT THERMAL IMPEDANCE vs. PULSE DURATION

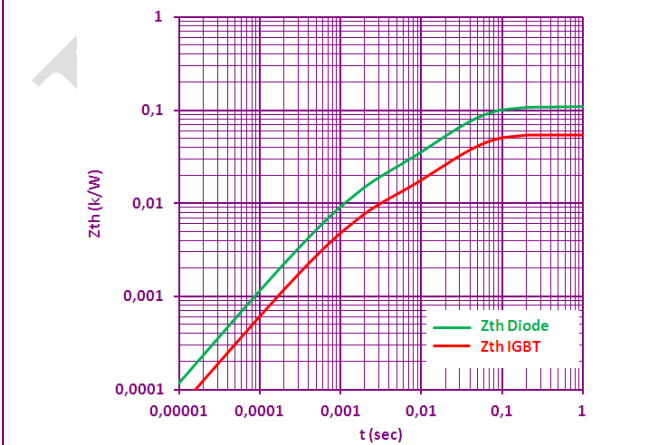
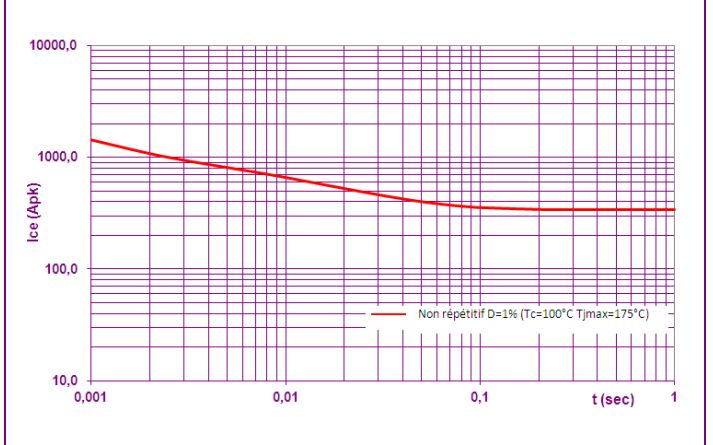

Fig. 8

ON-STATE PEAK OVERLOAD CURRENT vs. PULSE DURATION



Proud to serve you

Data given at T_{ambient}=40°C and subject to modification without previous notice

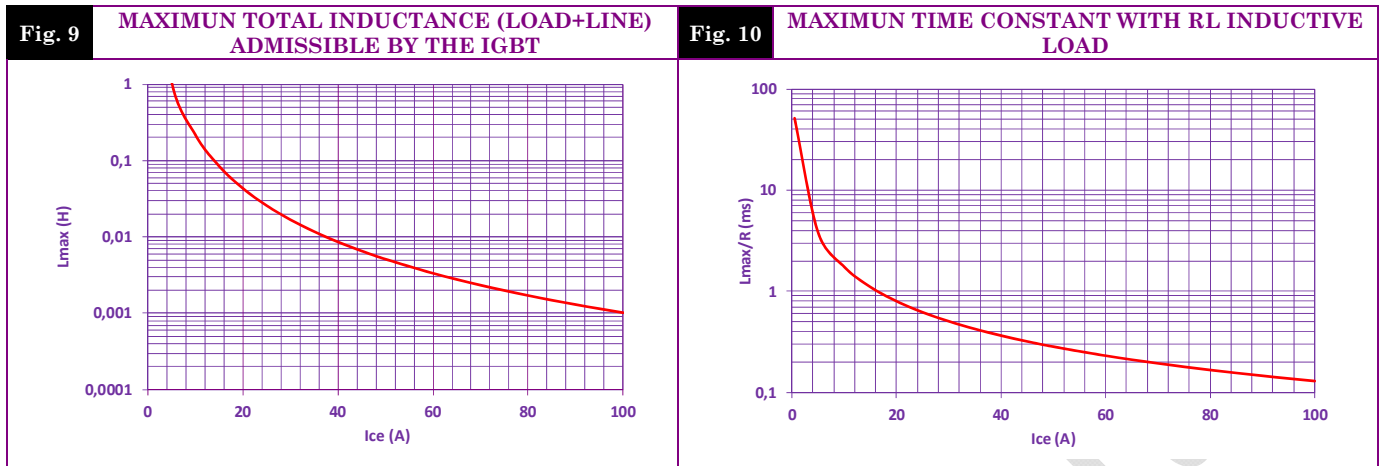

DIAGNOSTIC & STATUS OUTPUTS

CHARACTERISTIC	LABEL	VALUE	INFO.
Marking		X4/6 & X4/5 (Diagnostic Output) X4/4 & X4/3 (Status Output)	
Type of contact		Semiconductor (Photo-MOS) NO Contact ("Opened" without activation or supply)	
Nominal switching voltage		24 & 48Vdc	
Max. switching voltage		60Vdc	
Min. switching voltage		16.8Vdc	
Max. switching current		50mA	
Min. switching current		0.1mA	
Max. on-state resistance	Rds_on	35Ω	
Overvoltage protection		Transient voltage suppressor	
Overload and shorts-circuits protection		Thermistor	
Reverse polarity protection		YES	

DIAGNOSTIC & STATUS OUTPUTS

SUPPLY INPUT	CONTROL INPUT	MAIN VOLTAGE	LOAD CIRCUIT	RELAYS BASEPLATE TEMPERATURE	SUPPLY LED	STATUS LED	FAULT LED	DIAGNOSTIC OUTPUT	STATUS OUTPUT
0	x	x	x	x	○	○	○	Open	Open
UVLO	x	x	x	x	◐	○	○	Open	Open
1	0	YES	OK	<90°C	●	○	○	Open	Open
1	1	YES	OK	<90°C	●	●	○	Open	Closed
1	0	NO	OK	<90°C	●	○	◐	Closed	Open
1	0	YES	BREAKING	<90°C	●	●	◐	Closed	Open
1	1	YES	SHORT-CIRCUIT ^(*)	<90°C	●	○	◐	Closed	Open
1	x	x	x	>90°C	●	○	●	Closed	Open

LEGEND:

- Flashing ton=0,1s toff=0,1s
- Flashing ton=0,1s toff=2s
- Flashing ton=0,1s toff=0,1s

(*) After four Short-circuits and/or overload detection, the relay will be block for safety, this mode is indicated by a flashing chaser of leds, in this case the diagnostic output would be closed and the Status output would be open, to cancel this fault, you should reset the product with supply input (pin X4/10 et X4/9).

Proud to serve you

TIME CHARACTERISTICS

Fig. 2

TIME DIAGRAMS

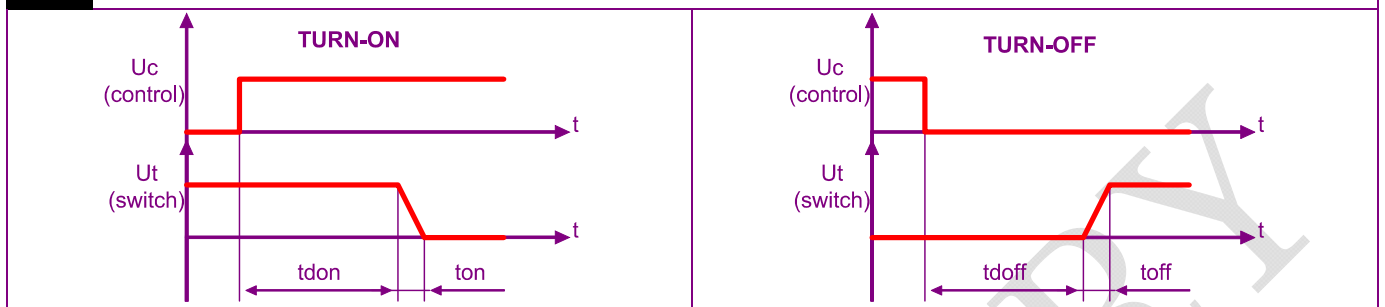

TIME CHARACT.	CHARACTERISTIC	LABEL	VALUE	INFO.
	Turn on time	ton	1µs	Rload=7.5Ω Lload=1mH Ue=750Vdc
	Turn on delay	tdon	1.5ms	
	Turn off time	toff	5µs	Rload=7.5Ω Lload=1mH Ue=750Vdc
	Turn off delay	tdoff	1.5ms	
Max. On-Off frequency	F(on-off)		1Hz	

GENERAL INFORMATION

WIRING	Connections	Power	Control
	Type	M6 Hexagonal screw	Cage spring with manual lever plug
	Tightening torque	3.75Nm	By pushing with DIN 5264 Screwdriver 0.4x2.5
	Recommended wiring type	round tabs, eyelet type, M6	1x1.5mm ² max

Plastic material housing	WELLAMID 6600 PA66 HWV0CP	
Mounting	4 screws M5	See mounting sheet
Noise level	No audible noise	
Weight	1050g	

STANDARDS

Proud to serve you

GENERAL	Standards		EN50155	
	Temperature class		TX	
	Protection level		IP00	
	CE marking		Yes	
	UL, cULUS and VDE approvals		Possible on request	
	Reliability		MTTF = 118 years MTTFd ≥ 24 years	ISO13849-1 @40°C/750Vdc and 50A

INSULATION	Standards		EN50124-1	
	Overvoltage categories		OV4	
	Pollution Degree		PD2	
	Rated impulse voltage between Input and Power outputs	Uni	8kV	
	Rated insulation voltage between Input and Power outputs	Unm	0.9kV	
	Rated impulse voltage between different signals of X4 connector (supply, control input, Diagnostic output and Status output)		2.5kV	
	Rated impulse voltage between Power output and ground (Aluminum baseplate)		4kV ^(*3)	

(*3) Warning: The rated impulse voltage test can damage the reliability of some components, we invite you to do this insulation test with reduced voltages (1500Vpk).

E.M.C. IMMUNITY	TYPE OF TEST	STANDARD	RESULTS	TESTS STANDARD
	E.S.D. (Electrostatic discharges)	EN50121-3-2		EN61000-4-2
	Radiated electromagnetic fields	EN50121-3-2		EN61000-4-3
	Fast transients bursts	EN50121-3-2		EN61000-4-4
	Electric chocks	EN50121-3-2		EN61000-4-5
	Radio-frequency fields	EN50121-3-2		EN61000-4-6

E.M.C. EMISSION	Radiated and conducted disturbances	EN50121-3-2		EN55011

OTHERS	Fire & smoke protection	EN45545-2	HL2 with requirement R22	
	Mechanical test Shocks and Vibrations	EN61373	PASS	

Proud to serve you

DIMENSIONS

Fig. 8

DIMENSIONS (in mm)

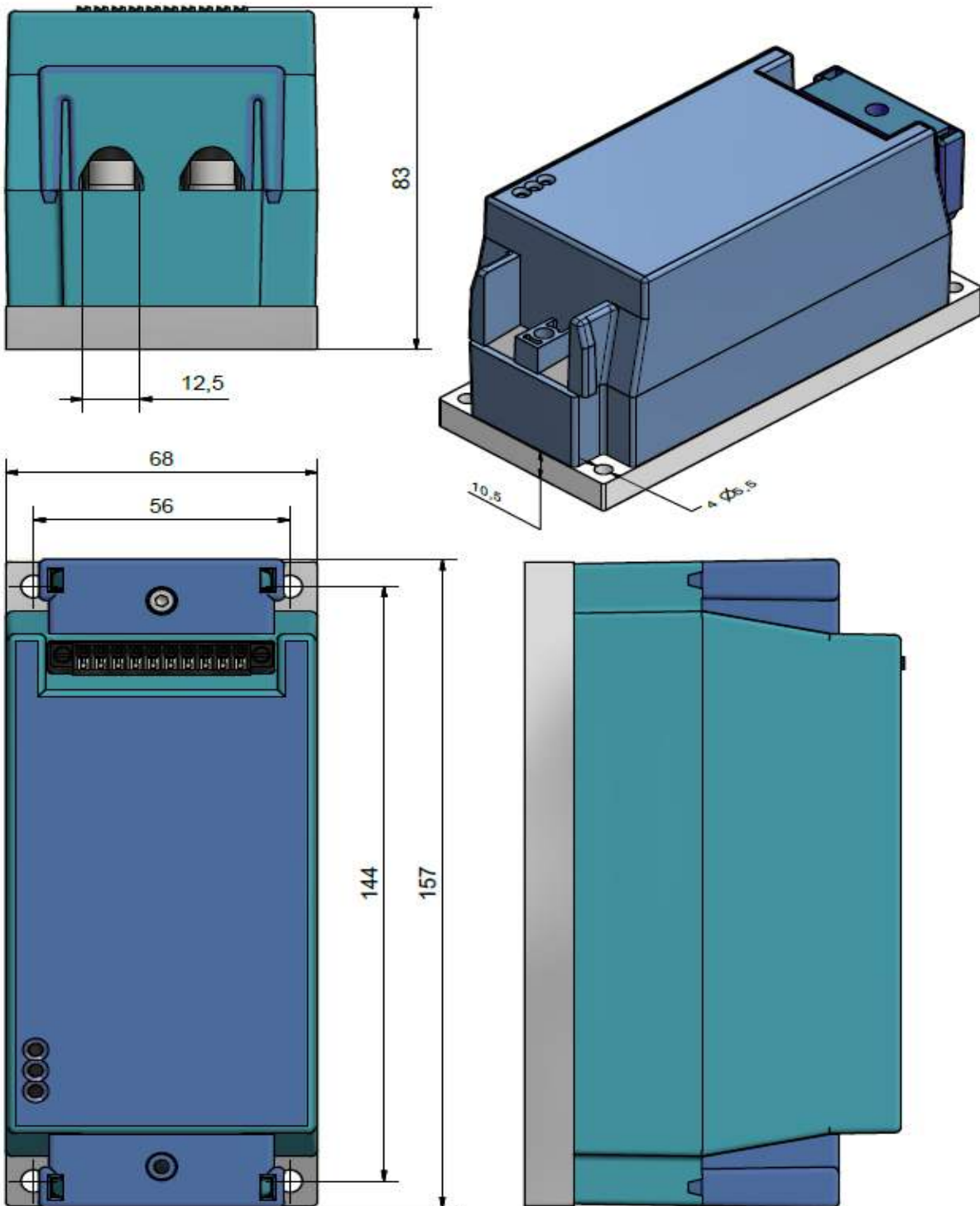

Proud to serve you

Data given at Tambient=40°C and subject to modification without previous notice

CONNECTIONS-WIRING

CONTROL CONNECTOR

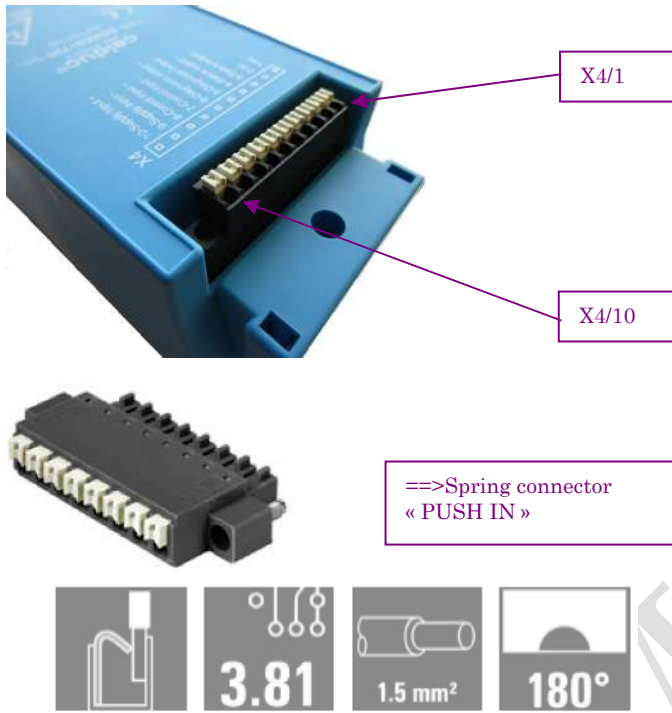

GROUND WIRING

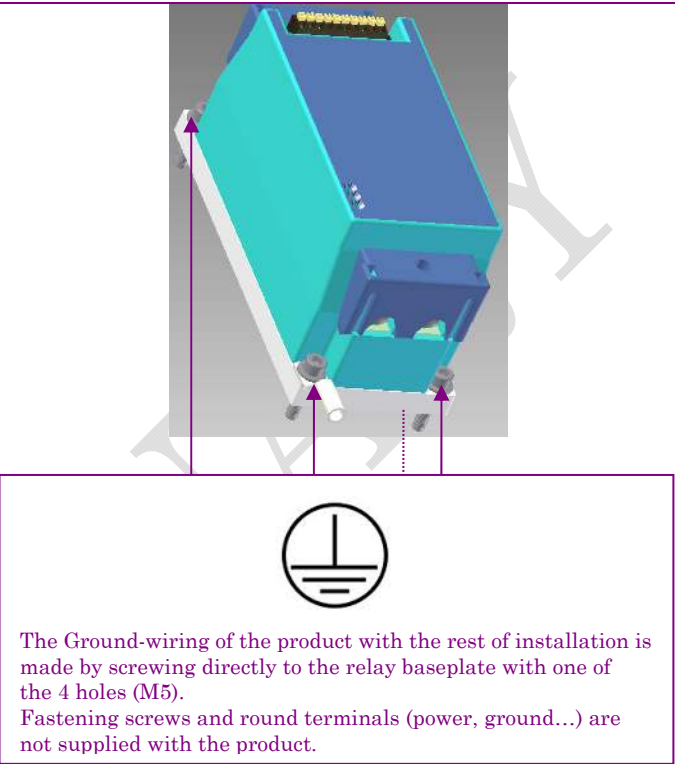

POWER WIRING

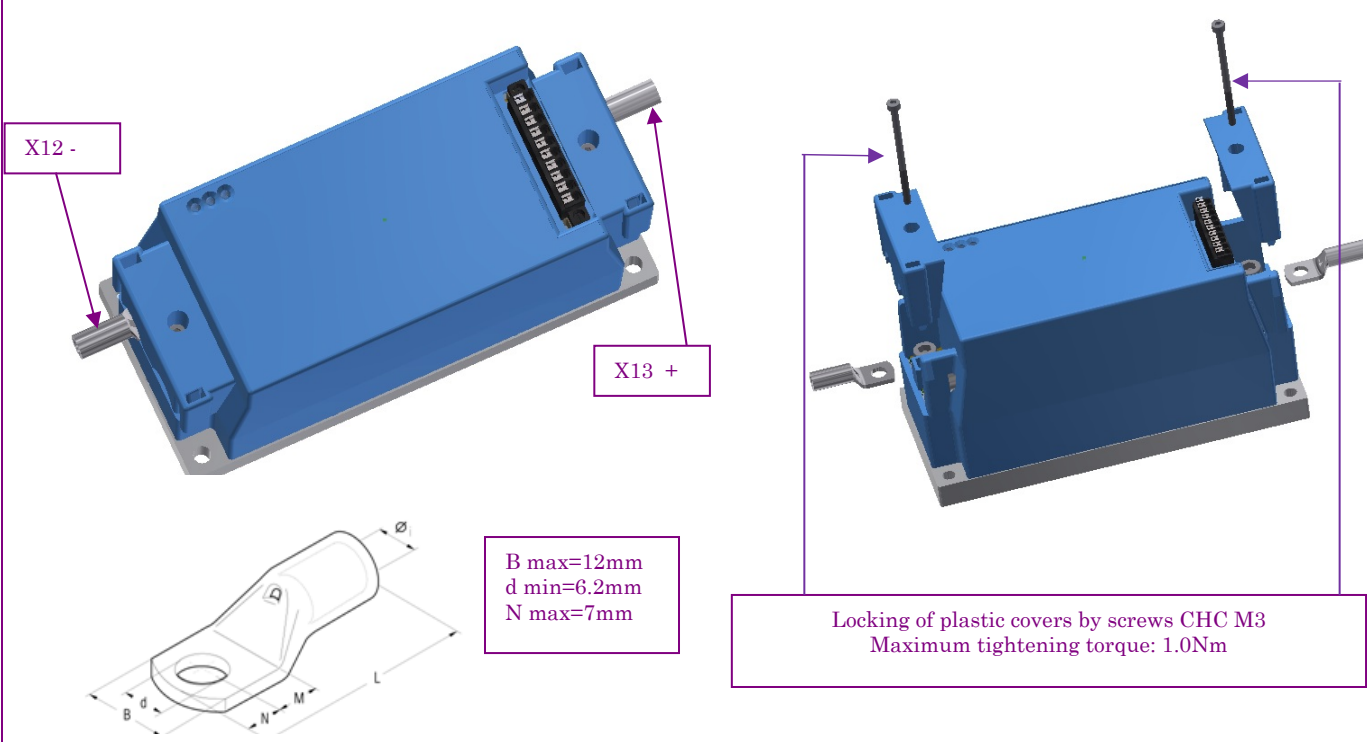

Proud to serve you

Data given at Tambient=40°C and subject to modification without previous notice

OPTIONS

Control connector with screws :

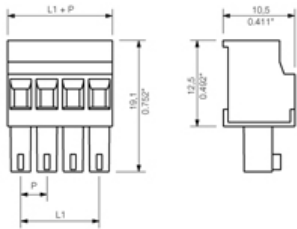
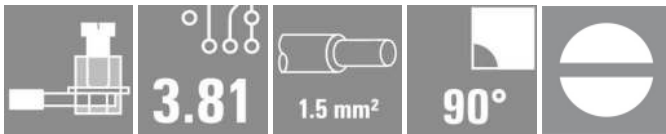

Connection kit for large cable ends :

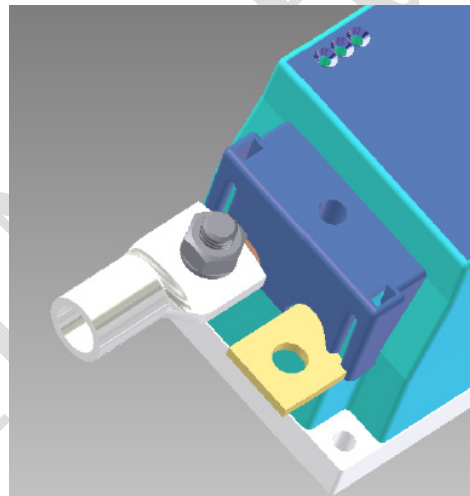
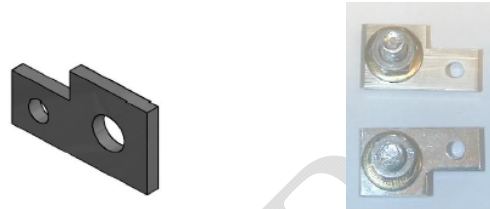

Please consult our website for other accessory references
(Heatsink, mounting adaptors, thermal grease...).