

APPROVAL SHEET

**WW20P, WW12P, WW10P, WW08P,
WW06P, WW04P**

±1%, ±5%

Thick Film High Power Current Sensing
Chip Resistors

Size 2010, 1206, 1210, 0805, 0603, 0402
(Automotive Grade Compliant)

*Contents in this sheet are subject to change without prior notice.

FEATURE

1. High power rating and compact size
2. Automotive AEC Q-200 Compliant
3. 100% CCD Visual inspection
4. RoHS compliant and Lead free products

APPLICATION

- Power supply
- PDA
- Digital meter
- Computer
- Automotives
- Battery charger
- DC-DC power converter

DESCRIPTION

The resistors are constructed in a high grade ceramic body (aluminum oxide). Internal metal electrodes are added at each end and connected by a resistive paste that is applied to the top surface of the substrate. The composition of the paste is adjusted to give the approximate resistance required and the value is trimmed to nominated value within tolerance which controlled by laser trimming of this resistive layer.

The resistive layer is covered with a protective coat. Finally, the two external end terminations are added. For ease of soldering the outer layer of these end terminations is a lead free tin alloy.

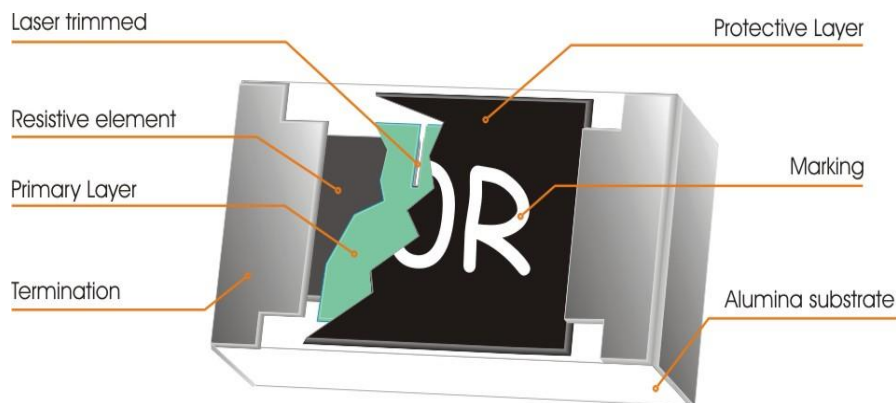

Fig 1. Construction of Chip-R

QUICK REFERENCE DATA

Item	General Specification					
Series No.	WW20P	WW10P	WW12P	WW08P	WW06P	WW04P
Size code	2010 (5025)	1210 (3225)	1206 (3216)	0805 (2012)	0603 (168)	0402 (1005)
Resistance Tolerance	±5%, ±1% (E24+E96)					
Resistance Range	0.010Ω ~ 0.976Ω	0.010Ω ~ 0.976Ω	0.047Ω ~ 0.976Ω	0.050Ω ~ 0.976Ω	0.100Ω ~ 0.976Ω	0.100Ω ~ 0.976Ω
TCR (ppm/°C)						
0.010 ~ 0.015R	0 ~ +1000	0 ~ +1000				
0.016 ~ 0.021R	0 ~ +800	0 ~ +800				
0.022 ~ 0.039R	0 ~ +600	0 ~ +600				
0.040 ~ 0.050R	0 ~ +400	0 ~ +500	0 ~ +400			
0.051 ~ 0.464R	0 ~ +200	0 ~ +250	0 ~ +200	0 ~ +200	0 ~ +250	0 ~ +300
0.470 ~ 0.976R	+/-100	+/-100	+/-100	+/-100	+/-100	0 ~ +200
Max. dissipation at T _{amb} =70°C	3/4 W	2/3W	1/2 W	1/3 W	1/4W	1/8W
Max. Operation Current	8.66 ~ 0.86A	8.12 ~ 0.81A	3.16 ~ 0.7A	2.56 ~ 0.57A	1.58 ~ 0.5A	1.11 ~ 0.35A
Operation Temperature	-55/+155°C					

MECHANICAL DATA (unit: mm)

Dimension	2010	1210	1206	0805	0603	0402
L	5.00 ± 0.20	3.10 ± 0.10	3.10 ± 0.10	2.00 ± 0.10	1.60 ± 0.10	1.00 ± 0.05
W	2.50 ± 0.20	2.60 ± 0.10	1.60 ± 0.10	1.25 ± 0.10	0.80 ± 0.10	0.50 ± 0.05
T	0.55 ± 0.10	0.55 ± 0.10	0.60 ± 0.15	0.50 ± 0.15	0.45 ± 0.15	0.35 ± 0.50
Tt	0.65 ± 0.25	0.50 ± 0.20	0.50 ± 0.20	0.40 ± 0.20	0.30 ± 0.10	0.20 ± 0.10
Tb	0.60 ± 0.25	0.50 ± 0.20	0.45 ± 0.20	0.40 ± 0.20	0.30 ± 0.20	0.25 ± 0.10

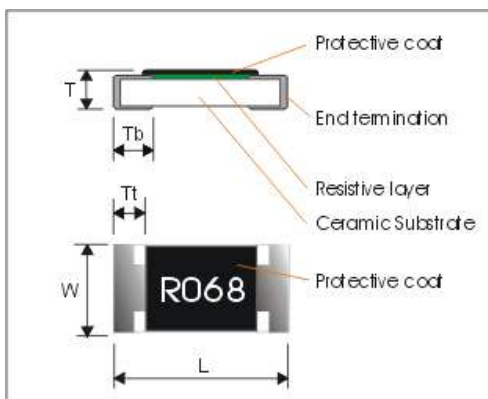

MARKING

For 0805/1206/1210/2010, each resistor is marked with a four-digit code on the protective coating to designate the nominal resistance value.

Example:

$$R100 = 0.10\Omega$$

$$R510 = 0.51\Omega$$

For 0603, each resistor is marked with a three-digit code on the protective coating to designate the nominal resistance value.

Example:

$$R10 = 0.10\Omega$$

$$R51 = 0.51\Omega$$

- 100m Ω -976m Ω , E96 series: The 1st two digit codes are referring to the code on the table, the 3rd code is the index of resistance value: "Z"(10⁻³)

(Example) "25Z" \rightarrow 178 [m Ω] \rightarrow 0.178[Ω]

"34Z" \rightarrow 221 [m Ω] \rightarrow 0.221[Ω]

- 1m Ω -99m Ω : The 3rd code is the index of resistance value: "M".

"M" = "m", means 1/1000

(Example) "75M" \rightarrow 75 [m Ω] \rightarrow 0.75[Ω]

"02M" \rightarrow 2 [m Ω] \rightarrow 0.02[Ω]

6.2.1 Symbol for E96 series of resistance value

E96	Symbol	E96	Symbol	E96	Symbol	E96	Symbol	E96	Symbol
100	01	162	21	261	41	422	61	681	81
102	02	165	22	267	42	432	62	698	82
105	03	169	23	274	43	442	63	715	83
107	04	174	24	280	44	453	64	732	84
110	05	178	25	287	45	464	65	750	85
113	06	182	26	294	46	475	66	768	86
115	07	187	27	301	47	487	67	787	87
118	08	191	28	309	48	499	68	806	88
121	09	196	29	316	49	511	69	825	89
124	10	200	30	324	50	523	70	845	90
127	11	205	31	332	51	536	71	866	91
130	12	210	32	340	52	549	72	887	92
133	13	215	33	348	53	562	73	909	93
137	14	221	34	357	54	576	74	931	94
140	15	226	35	365	55	590	75	953	95
143	16	232	36	374	56	604	76	976	96
147	17	237	37	388	57	619	77		
150	18	243	38	392	58	634	78		
154	19	249	39	402	59	649	79		
158	20	255	40	412	60	665	80		

For 0402, no marking is defined!

FUNCTIONAL DESCRIPTION

Product characterization

Standard values of nominal resistance are taken from the E96 & E24 series for resistors with a tolerance of $\pm 5\%$ & $\pm 1\%$. The values of the E24/E96 series are in accordance with "IEC publication 60063".

Derating curve

The power that the resistor can dissipate depends on the operating temperature; see Fig.3

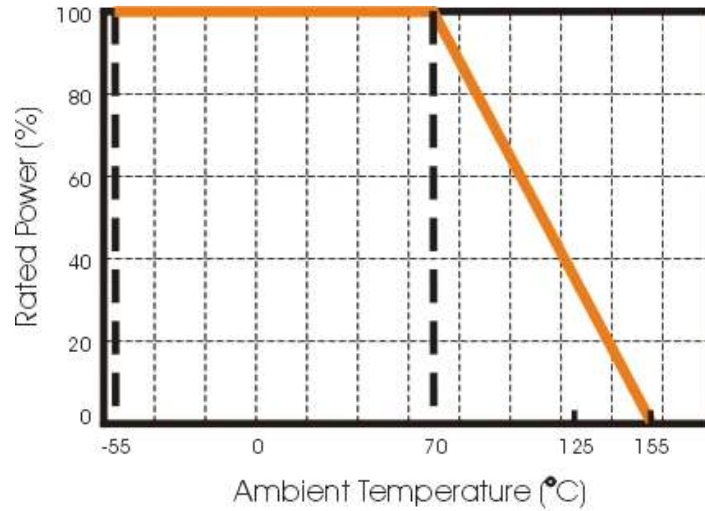

Fig 3. Max. dissipation in percentage of rated power as a function of the ambient temperature

MOUNTING

Due to their rectangular shapes and small tolerances, Surface Mountable Resistors are suitable for handling by automatic placement systems.

Chip placement can be on ceramic substrates and printed-circuit boards (PCBs).

Electrical connection to the circuit is by individual soldering condition.

The end terminations guarantee a reliable contact.

SOLDERING CONDITION

The robust construction of chip resistors allows them to be completely immersed in a solder bath of 260°C for 10 seconds. Therefore, it is possible to mount Surface Mount Resistors on one side of a PCB and other discrete components on the reverse (mixed PCBs).

Surface Mount Resistors are tested for solderability at 235°C during 2 seconds. The test condition for no leaching is 260°C for 30 seconds. Typical examples of soldering processes that provide reliable joints without any damage are given in Fig 4.

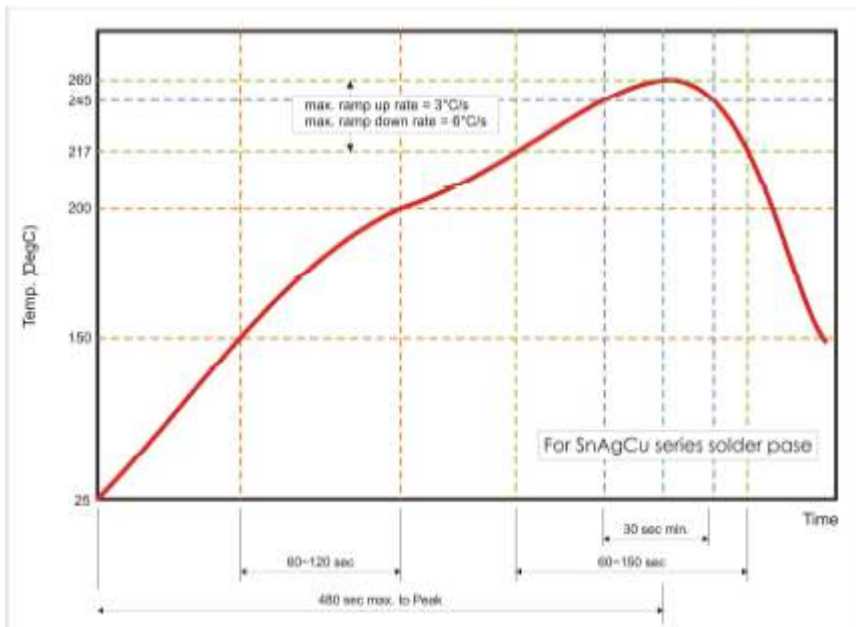

Fig 4. Infrared soldering profile for Chip Resistors

CATALOGUE NUMBERS

The resistors have a catalogue number starting with .

WW20	P	R100	J	T	L	J
Size code WW20 : 2010 WW10 : 1210 WW12 : 1206 WW08 : 0805 WW06 : 0603 WW04 : 0402	Type code P : Power	Resistance code E96 +E24: R is first digit followed by 3 significant digits. 0.10Ω = R100	Tolerance J : ±5% F : ±1%	Packaging code T : Reeled	Termination code L = Sn base (lead free)	Special code J = Automotive grade AEC Q-200 compliant, 100% CCD visual inspection

TEST AND REQUIREMENTS (AEC Q-200)

TEST	PROCEDURE / TEST METHOD	REQUIREMENT
High Temperature Exposure MIL-STD-202 Method 108	1000+48/-0 hours; without load in a temperature chamber controlled 155±2°C	ΔR/R max. ±3% No visible damage
Temperature cycling JESD22 Method JA-104	1000 cycles, -55°C ~ +125°C, dwell time 30min maximum.	ΔR/R max. ±1% No visible damage
Moisture Resistance MIL-STD-202 method 106	65±2°C, 80~100% RH, 10 cycles, 24 hours/ cycle	ΔR/R max. ±1% No visible damage
Bias Humidity MIL-STD-202 method 103	1000+48/-0 hours; 85°C, 85% RH, 10% of operation power.	ΔR/R max. ±3% No visible damage
Operational Life MIL-STD-202 method 108	1000+48/-0 hours; 35% of operation power, 125±2°C	ΔR/R max. ±3% No visible damage
Dimension JESD22 method JB-100	Verify physical dimensions (L, W, T, Tb, Tt)	Within the specified tolerance for WTC.
Resistance to Solvents : MIL-STD-202 Method 215	Solvent is Isopropyl alcohol, immersion 3mins at 25°C and brush 10 strokes with a toothbrush with a handle made of a non-reactive material (wet bristle), immersion and brush 3 times and then air blow dry.	ΔR/R max. ±1% No visible damage
Mechanical Shock MIL-STD-202 method 213	Test ½ Sine Pulse, Peak value: 100g, normal duration: 6ms, Velocity change:12.3ft/sec. 10 shocks in each direction, total 30 shocks.	ΔR/R max. ±1% No visible damage.
Vibration MIL-STD-202 method 204	Test 5g's for 20 min., 12 cycles each of 3 orientations.	ΔR/R max. ±1% No visible damage.
Thermal shock MIL-STD-202 method 107	Test -55 to 155°C/ dwell time 15min/ Max transfer time 20sec 300cycles	ΔR/R max. ±1% No visible damage
Resistance to soldering heat (R.S.H) MIL-STD-202 method 210	Un-mounted chips completely immersed for 10±1second in a SAC solder bath at 260°C±5°C	ΔR/R max. ±1% no visible damage
ESD AEC-Q200-002	Human body model 2Kohm, 150pF, Test voltage: 0402/0603: 1KV ; 0805 & above sizes: 4KV	ΔR/R max. ±3% No visible damage
Solderability J-STD-002	a) Bake the sample for 155°C dwell time 4hrs/ solder dipping 235°C/ 5sec. b) Steam the sample dwell time 8 hour/ solder dipping 215°C/ 5sec. c) Steam the sample dwell time 8 hour/ solder dipping 260°C/ 7sec.	95% coverage min., good tinning and no visible damage
Electrical Characteristics JISC5201-1: 1998 Clause 4.8	- DC resistance values measurement - Temperature Coefficient of Resistance (T.C.R) Natural resistance change per change in degree centigrade. $\frac{R_2 - R_1}{R_1(t_2 - t_1)} \times 10^6 \text{ (ppm/}^\circ\text{C)} \quad t_1 : 20^\circ\text{C}+5^\circ\text{C}-1^\circ\text{C}$ R ₁ : Resistance at reference temperature R ₂ : Resistance at test temperature +155°C	Within the specified tolerance Refer to "QUICK REFERENCE DATA"

Approval sheet

Bending strength AEC-Q200-005	Resistors mounted on a 90mm glass epoxy resin PCB(FR4),bending once 2mm for 60sec.	$\Delta R/R$ max. $\pm 1\%$ No visible damage
Adhesion AEC-Q200-006	Pressurizing force: 0402/0603: 10N 0805/1206/1210/2010: 17.7N Test time: 60 \pm 1sec.	$\Delta R/R$ max. $\pm 1\%$ No remarkable damage or removal of the terminations

PACKAGING

Tape specifications (unit: mm)

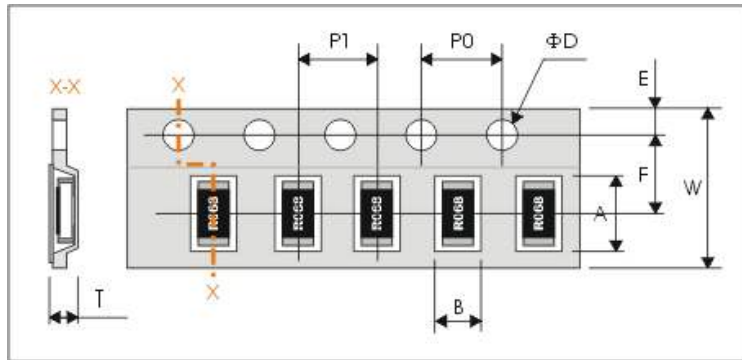

Type	A	B	W	F	E
WW20	5.50±0.20	2.80±0.20	12.00±0.30	5.50±0.1	1.75±0.10
WW12	3.60±0.20	2.00±0.20	8.00±0.30	3.50±0.2	1.75±0.10
WW10	3.50±0.20	2.85±0.20	8.00±0.30	3.50±0.2	1.75±0.10
WW08	2.40±0.20	1.65±0.20	8.00±0.30	3.50±0.2	1.75±0.10
WW06	1.90±0.20	1.10±0.20	8.00±0.30	3.50±0.2	1.75±0.10
WW04	1.20±0.20	0.70±0.20	8.00±0.30	3.50±0.2	1.75±0.10

Type	P1	P0	ΦD	T
WW20	4.00±0.10	4.00±0.10	Φ1.50 ^{+0.1} _{-0.0}	Max. 1.2
WW12	4.00±0.10	4.00±0.10		Max. 1.0
WW10	4.00±0.10	4.00±0.10		Max. 1.2
WW08	4.00±0.10	4.00±0.10		Max. 1.0
WW06	4.00±0.10	4.00±0.10		0.65±0.05
WW04	2.00±0.10	4.00±0.10		0.40±0.05

Reel dimensions

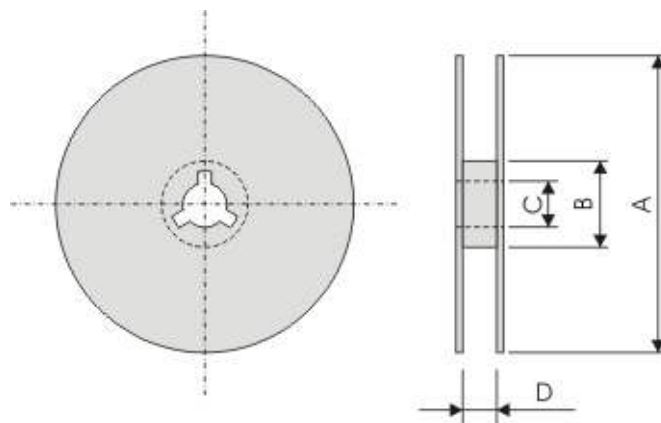

(unit : mm)	A	B	C	D
WW20	Φ178.0±2.0	Φ60.0±1.0	13.0±0.2	14±0.2
WW12/ 10/ 08/ 06/ 04	Φ178.0±2.0	Φ60.0±1.0	13.0±0.2	9.0±0.5

Taping Quantity

- WW20 by plastic tape taping 4,000 pcs per reel.
- WW12, WW10, WW08, WW06 by paper tape taping 5,000 pcs per reel
- WW04 by paper tape taping 10,000 pcs per reel
-