

CMS100N03H8-HF

**N-Channel
RoHS Device
Halogen Free**

Features

- Low on-resistance.
- Low miller charge.
- Low input capacitance.
- 100% EAS and Rg guaranteed.
- Green device available.

Mechanical data

- Case: PR-PAK

Circuit Diagram

- G : Gate
- S : Source
- D : Drain

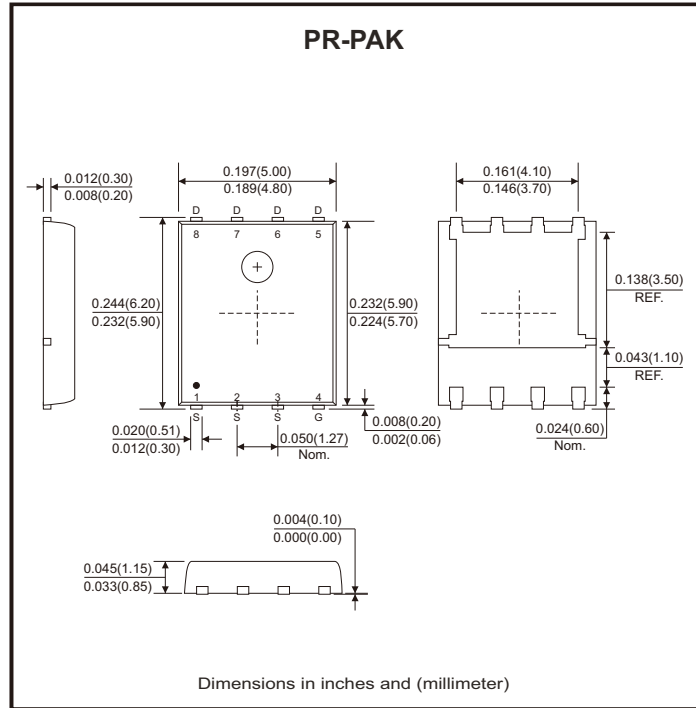
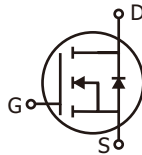

Maximum Ratings

Parameter	Conditions	Symbol	Value	Unit
Drain-source voltage		V_{DS}	30	V
Gate-source voltage		V_{GS}	± 20	V
Continuous drain current (Note 1)	$T_c = 25^\circ\text{C}$	I_D	100 (Note 3)	A
	$T_c = 70^\circ\text{C}$	I_D	80	
Pulsed drain current (Note 1)		I_{DM}	500	A
Continuous drain current	$T_A = 25^\circ\text{C}$	I_D	38	A
	$T_A = 70^\circ\text{C}$	I_D	30	
Total power dissipation	$T_c = 25^\circ\text{C}$	P_D	83	W
	$T_A = 25^\circ\text{C}$	P_D	3.6	
Single pulse avalanche energy, $L=0.1\text{mH}$		E_{AS}	151	mJ
Single pulse avalanche current, $L=0.1\text{mH}$		I_{AS}	55	A
Operating junction and storage temperature range		T_J, T_{STG}	-55 to +150	$^\circ\text{C}$
Thermal resistance junction-ambient (Note 2)	Steady state	$R_{\theta JA}$	35	$^\circ\text{C/W}$
Thermal resistance junction-case (Note 2)	Steady state	$R_{\theta JC}$	1.5	$^\circ\text{C/W}$

Notes: 1. The data tested by pulsed, pulse width $\leq 300\mu\text{s}$, duty cycle $\leq 2\%$.

2. $R_{\theta JA}$ is the sum of the junction-to-case and case-to-ambient thermal resistance where the case thermal reference is defined as the solder mounting surface of the drain pins. $R_{\theta JC}$ is guaranteed by design while $R_{\theta CA}$ is determined by the user's board design. $R_{\theta JA}$ shown below for single device operation on FR-4 in still air.

3. Package limitation current is 100A.

Company reserves the right to improve product design, functions and reliability without notice.

REV:A

Electrical Characteristics (at $T_J=25^{\circ}\text{C}$ unless otherwise noted)

Parameter	Symbol	Conditions	Min	Typ	Max	Unit
Drain-source breakdown voltage	BV_{DSS}	$V_{GS} = 0V, I_D = 250\mu A$	30			V
Gate threshold voltage	$V_{GS(th)}$	$V_{DS} = V_{GS}, I_D = 250\mu A$	1.2		2.5	
Gate-source leakage current	I_{GSS}	$V_{GS} = \pm 20V$			± 100	nA
Drain-source leakage current	I_{DSS}	$V_{DS} = 24V, V_{GS} = 0V$			1	μA
Static drain-source on-resistance (Note 1)	$R_{DS(on)}$	$V_{GS} = 10V, I_D = 30A$		1.5	1.8	m Ω
		$V_{GS} = 4.5V, I_D = 15A$		2.1	2.4	
Total gate charge (Note 1)	Q_g	$I_D = 30A, V_{DS} = 15V, V_{GS} = 10V$		82		nC
Gate-source charge	Q_{gs}			24		
Gate-drain ("miller") charge	Q_{gd}			5		
Turn-on delay time (Note 1)	$t_{d(on)}$	$V_{DS} = 15V, I_D = 30A,$ $V_{GS} = 10V, R_G = 3\Omega$		22		nS
Rise time	t_r			7		
Turn-off delay time	$t_{d(off)}$			100		
Fall time	t_f			18		
Input capacitance	C_{iss}	$V_{GS} = 0V, V_{DS} = 15V, f = 1MHz$		4222		pF
Output capacitance	C_{oss}			889		
Reverse transfer capacitance	C_{rss}			389		
Gate resistance	R_g	$f = 1MHz$			3.0	Ω
Source-drain diode						
Diode forward voltage (Note 1)	V_{SD}	$I_S = 30A, V_{GS} = 0V$			1.3	V
Reverse recovery time	t_{rr}	$I_F = 30A, dI/dt = 100A/\mu s$ $T_J = 25^{\circ}\text{C}$		32		nS
Reverse recovery charge	Q_{rr}			120		nC
Guaranteed avalanche characteristics						
Single pulse avalanche energy (Note 2)	EAS	$V_{DD} = 20V, L = 0.1mH, I_{AS} = 45A$	101			mJ

Notes: 1. The data tested by pulsed, pulse width $\leq 300\mu s$, duty cycle $\leq 2\%$.

2. The min. value is 100% EAS tested guarantee.

Rating and Characteristic Curves (CMS100N03H8-HF)

Fig.1 - Typical Output Characteristics

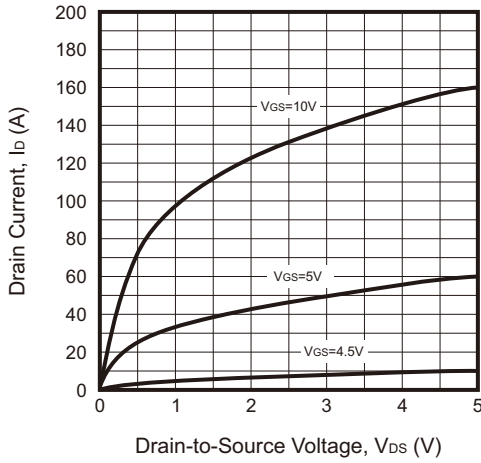

Fig.2 - On-Resistance vs. G-S Voltage

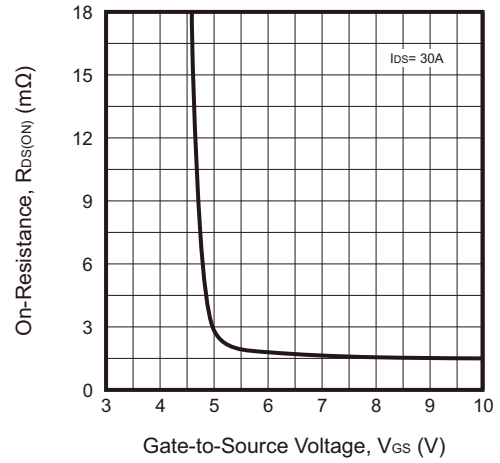

Fig.3 - On-Resistance vs. Drain Current

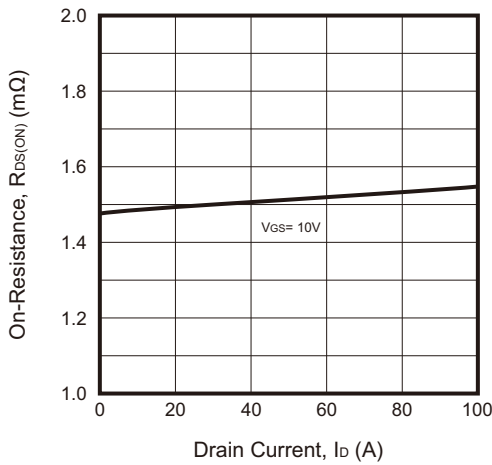

Fig.4 - Normalized $R_{DS(ON)}$ vs. T_J

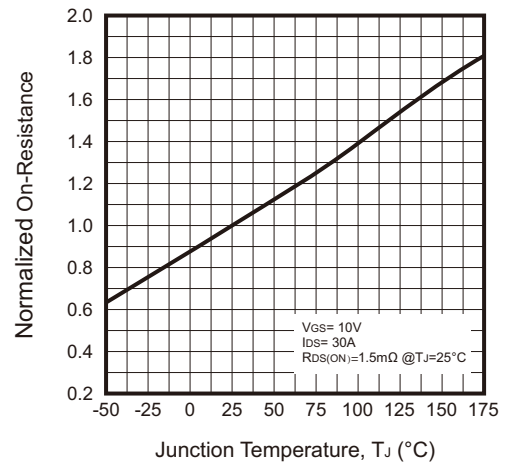

Fig.5 - Normalized $V_{GS(th)}$ vs. T_J

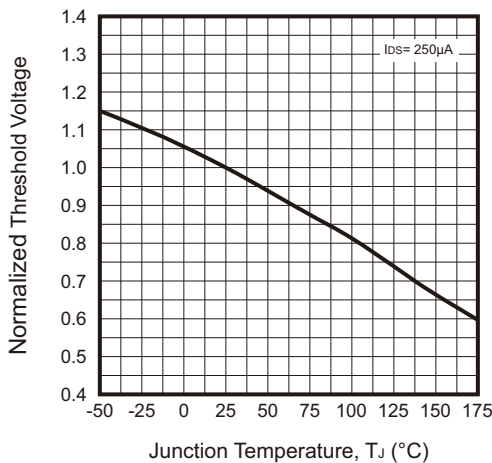
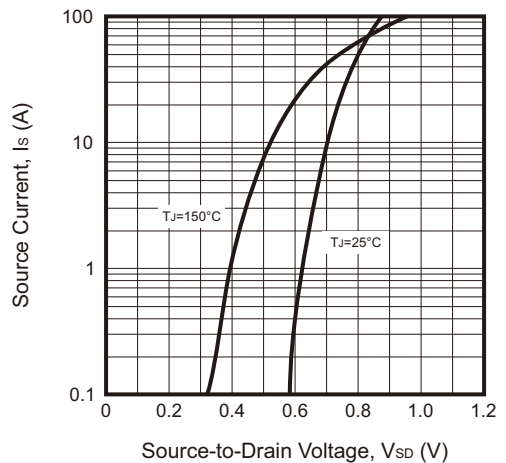

Fig.6 - Forward Characteristics of Reverse



Rating and Characteristic Curves (CMS100N03H8-HF)

Fig.7 - Gate Charge Characteristics

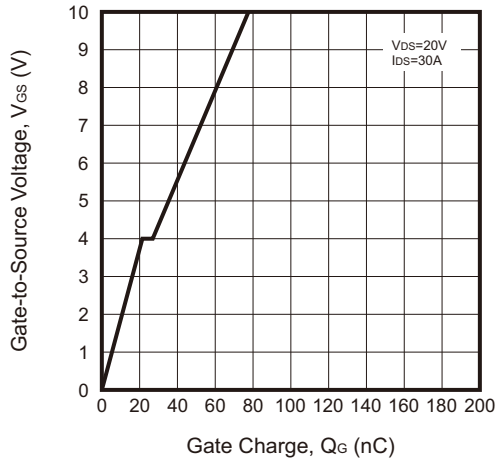

Fig.8 - Capacitance Characteristics

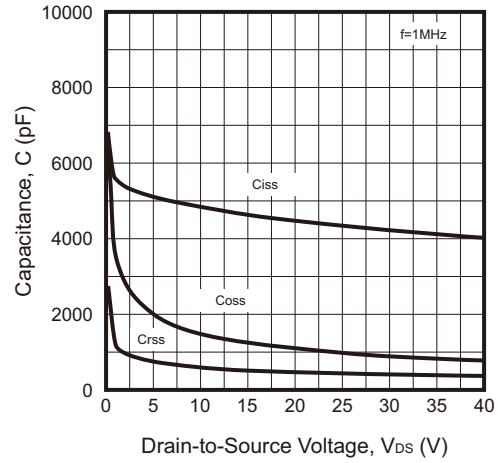

Fig.9 - Safe Operating Area

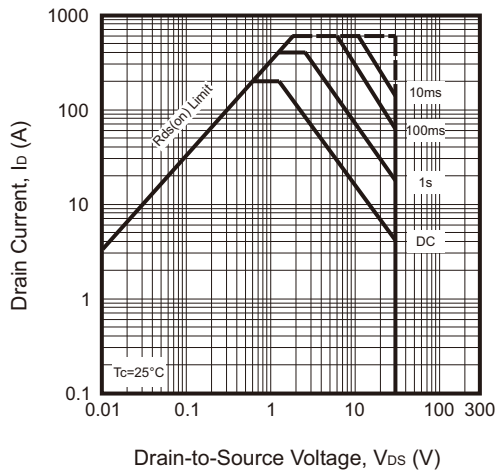

Fig.10 - Power Dissipation

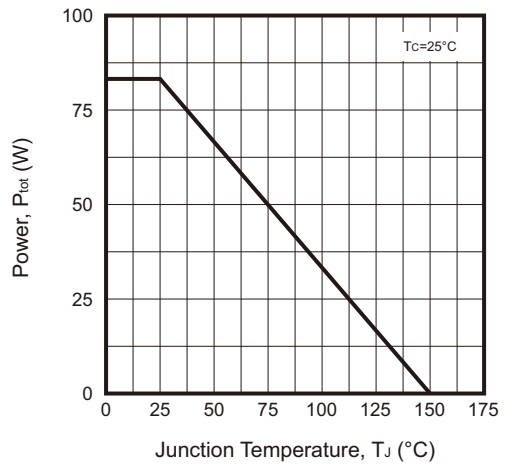
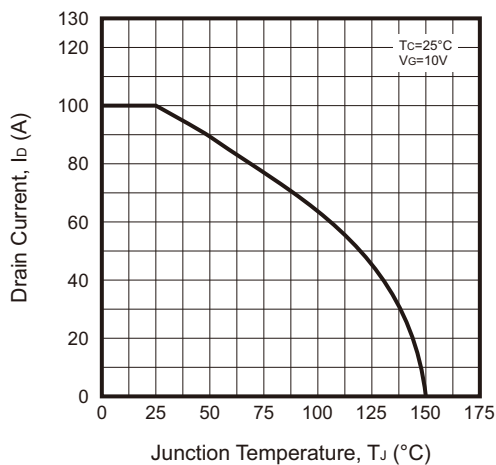
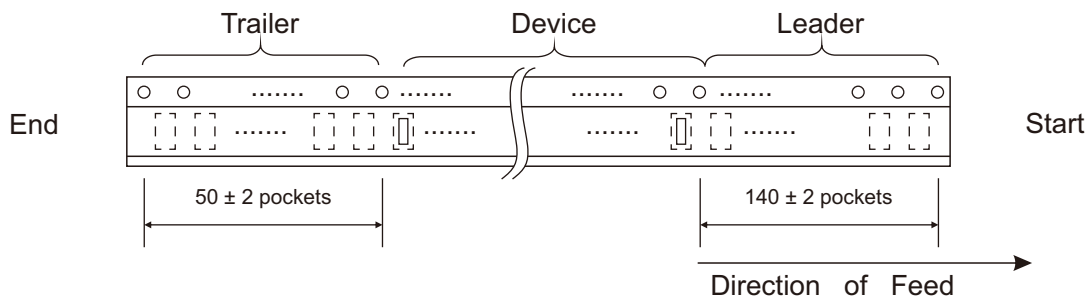
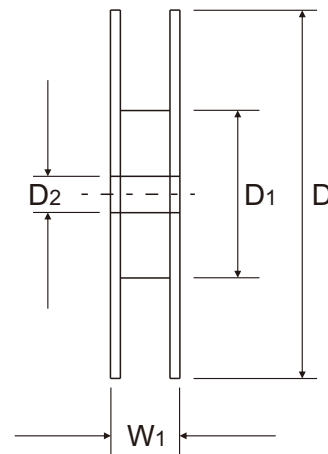
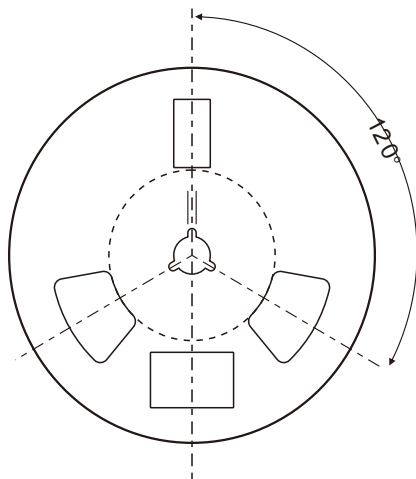
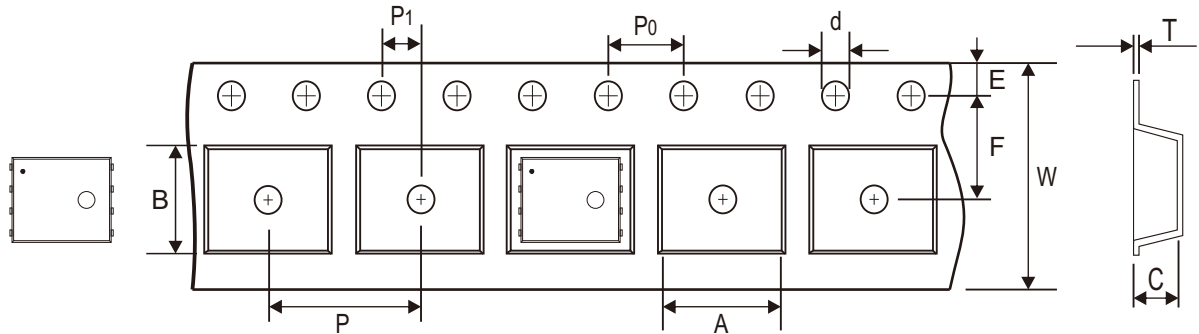

Fig.11 - Drain Current vs. T_J



Reel Taping Specification



PR-PAK	SYMBOL	A	B	C	d	D	D1	D2
	(mm)	6.50 ± 0.10	5.30 ± 0.10	1.40 ± 0.10	1.50 + 0.10 - 0.00	330.00 ± 1.00	178.00 + 0.00 - 2.00	13.00 min.
	(inch)	0.256 ± 0.004	0.209 ± 0.004	0.055 ± 0.004	0.059 + 0.004 - 0.000	12.992 ± 0.039	7.008 + 0.000 - 0.079	0.512 min.

PR-PAK	SYMBOL	E	F	P	P0	P1	T	W	W1
	(mm)	1.75 ± 0.10	5.50 ± 0.05	8.00 ± 0.10	4.00 ± 0.10	2.00 ± 0.05	0.30 ± 0.05	12.00 ± 0.30	18.40 ref.
	(inch)	0.069 ± 0.004	0.217 ± 0.002	0.315 ± 0.004	0.157 ± 0.004	0.079 ± 0.002	0.012 ± 0.002	0.472 ± 0.012	0.724 ref.

Company reserves the right to improve product design , functions and reliability without notice. REV:A

Marking Code

Part Number	Marking Code
CMS100N03H8-HF	30N07 XXXX

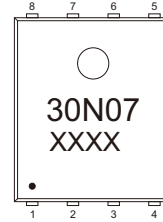

XXXX = Control code

Suggested PAD Layout

SIZE	PR-PAK	
	(mm)	(inch)
A	1.27	0.050
B	0.61	0.024
C	4.42	0.174
D	1.27	0.050
E	6.61	0.260
F	4.32	0.170
G	4.52	0.178
H	3.81	0.150
I	3.91	0.154

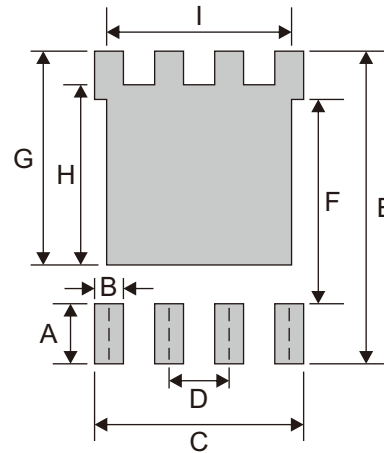

Note: 1. The pad layout is for reference purposes only.

Standard Packaging

Case Type	REEL PACK	
	REEL (pcs)	Reel Size (inch)
PR-PAK	3,000	13