

**SECTION B-B
END VIEW**

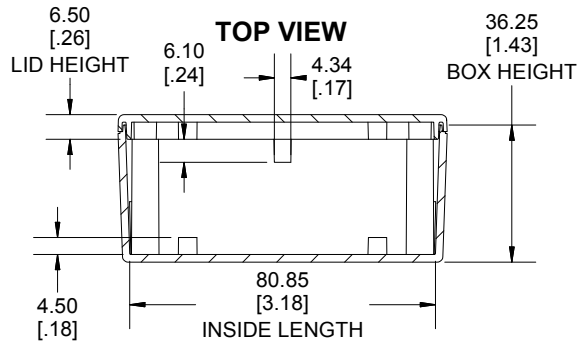

**SECTION A-A
SIDE VIEW**

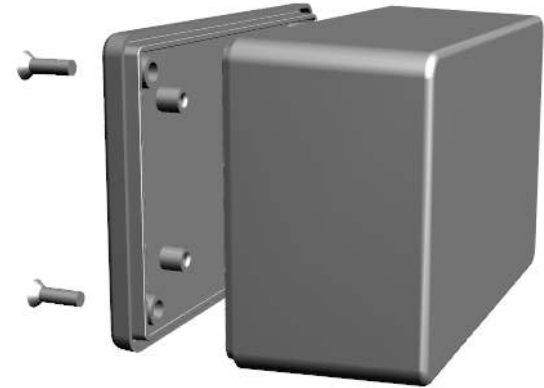
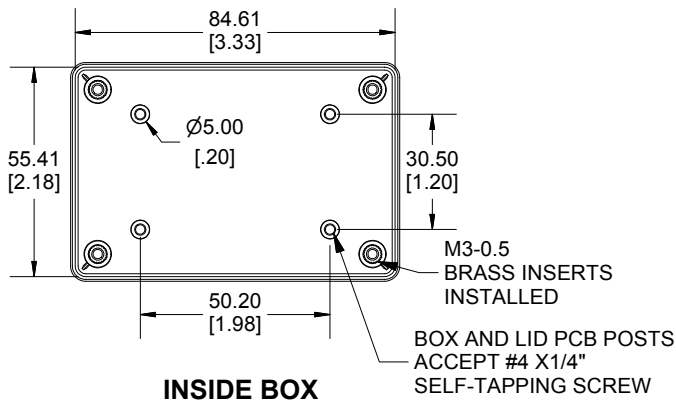
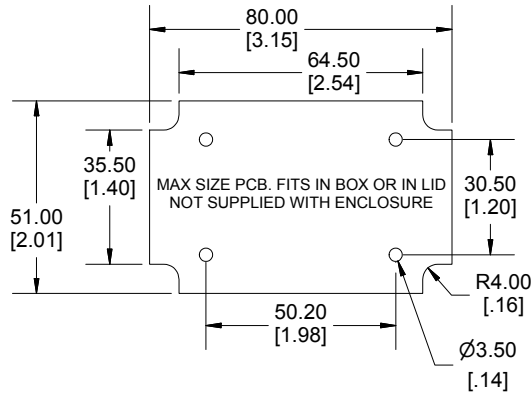

INSIDE BOX

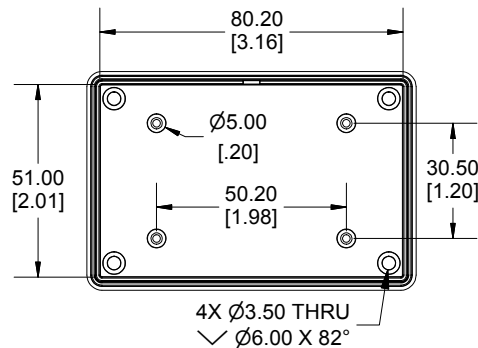

INSIDE LID

Enclosures can be Factory Modified (Milling, Drilling, Printing etc.)
Contact Factory mjm@hammondmfg.com for quotes
Solid models of this enclosure available in STEP or IGES.
(Part number and text placement/orientation on our products are subject to change, we do not recommend using them as a locating reference for modification purposes)

NOTE

Purchased assembly includes box, lid, 4 cover screws and installed brass inserts.
Enclosure molded from FRABS UL 94-V0 Plastic.
Other materials / colours available consult factory.

Recommended Torque : (43-50) Ozf.in / (30-35) cNm

PART NUMBERS

| 1591XXL Enclosure | |
|------------------------------------|-----------------------|
| Black Textured Enclosure | 1591XLEK |
| Gray Textured Enclosure | 1591XLGY |
| ACCESSORIES | |
| Black Cover Screws [M3-0.5 X10mm] | 1591MS100BK (Pkg 100) |
| Plated Cover Screws [M3-0.5 X10mm] | 1591MS100 (Pkg 100) |
| P.C. Board Screws | 1593ATS60 (Pkg 50) |
| [#4 x 1/4" self-tapping (6.4mm)] | 1593ATS100 (Pkg 100) |

**HAMMOND
MANUFACTURING®**
1591XXL
www.hammondmfg.com

Dimensions:
mm
[inches]