

L712RAH

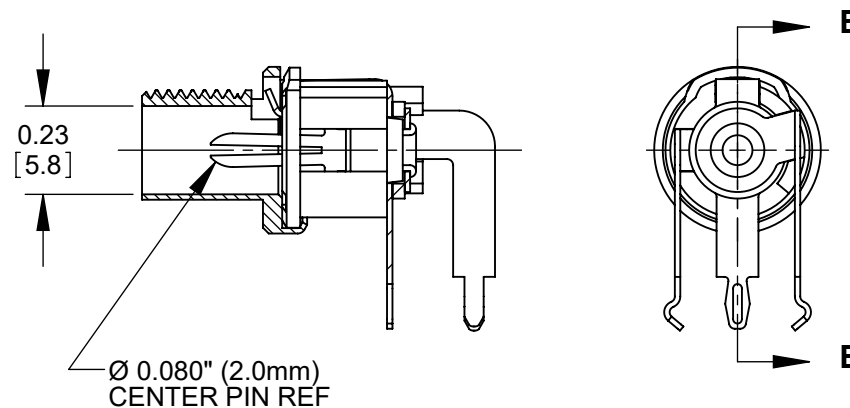

L722RAH

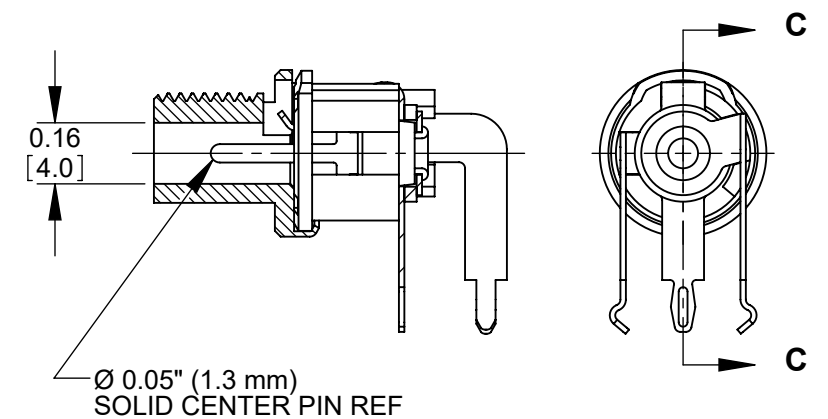

L732RAH

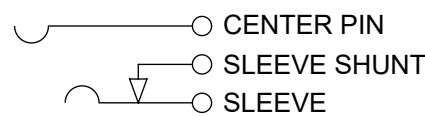
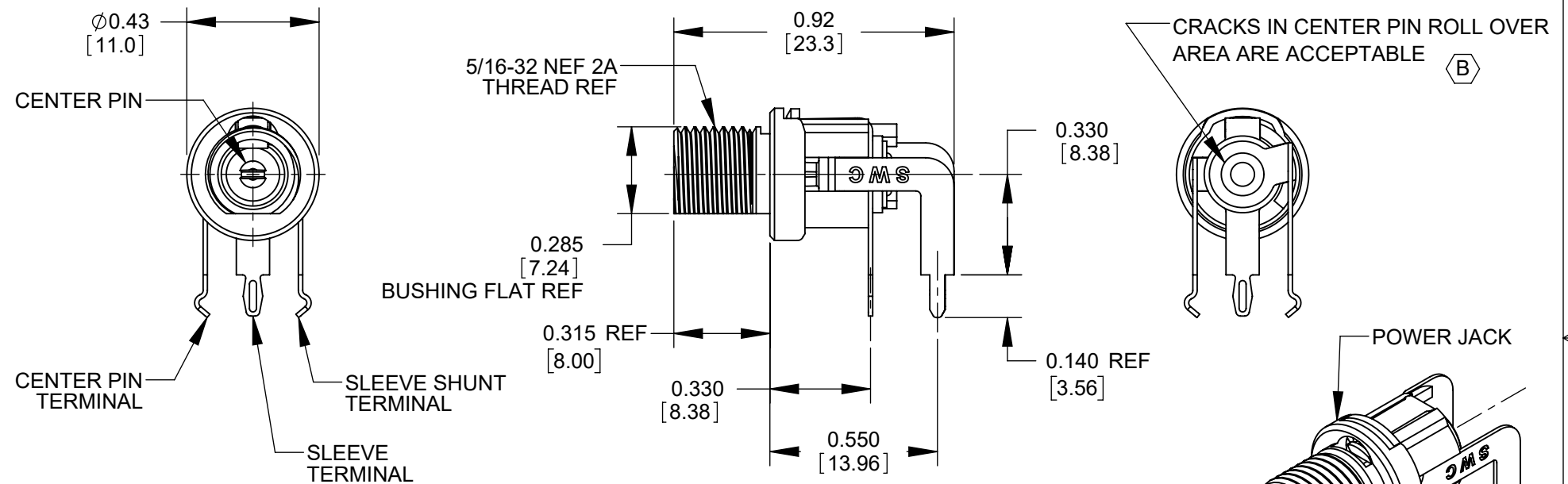
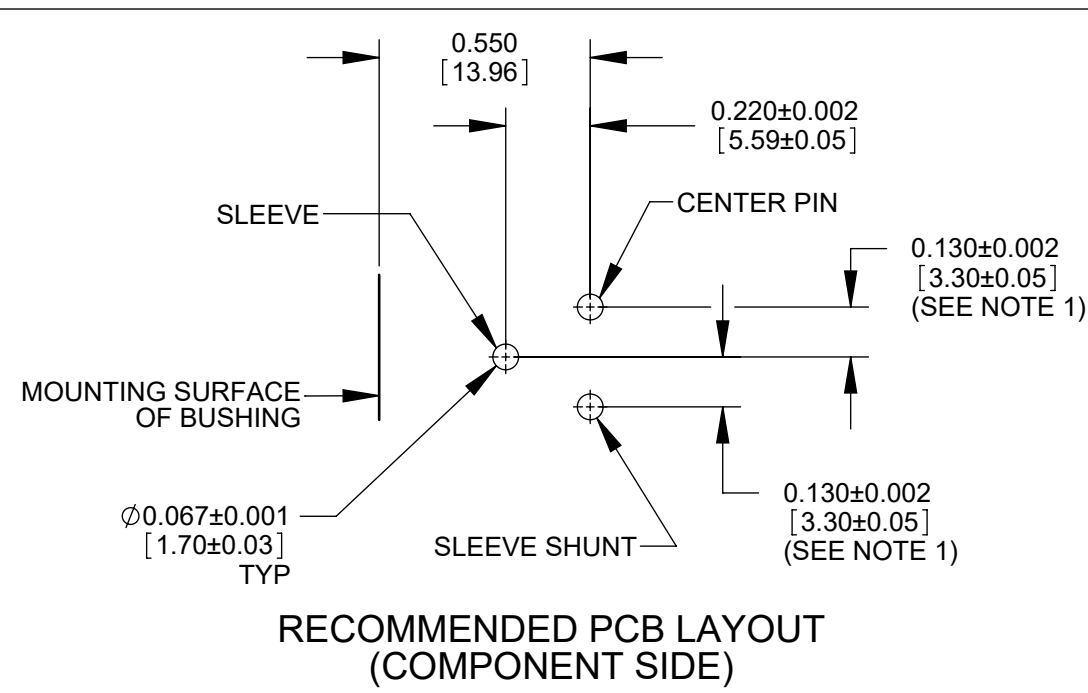

SCHEMATIC

NOTES:

- FOR HAND INSERTION USE SPACING 0.130 [3.30]
FOR AUTOMATED INSERTION USE SPACING 0.135 [3.43]
- DIMENSIONS SHOWN FOR REFERENCE ONLY.
- HEX NUT AND FLAT WASHER SUPPLIED UNASSEMBLED.
- MATERIAL:**
HOUSING, HEX NUT - COPPER ALLOY, NICKEL PLATED
INSULATOR HOUSING - THERMOPLASTIC, WHITE
TERMINAL INSULATORS - PHENOLIC
FLAT WASHER - STEEL, NICKEL PLATED
PIN, SPRING, TERMINALS - COPPER ALLOY, SILVER PLATED
- IT IS RECOMMENDED THAT THE JACK MOUNTING NUT BE TIGHTENED SNUG BY HAND BEFORE APPLYING A FINAL TIGHTENING TORQUE OF 8-10 LB-IN USING HAND TOOLS ONLY. POWER DRIVER OR IMPACT DRIVERS ARE NOT RECOMMENDED.
- THESE PRODUCTS ARE RoHS COMPLIANT

REV	ECO NUMBER	DATE	BY	APVD
B	28397	06/11/21	PC	TJK
A	27941	09/06/17	PC	TJK

UNLESS OTHERWISE SPECIFIED

- ALL DIMENSIONS IN INCHES [mm]
- TWO PLACE DECIMALS ±0.02 [0.5]
- THREE PLACE DECIMALS ±0.005 [0.13]

DO NOT SCALE DRAWING

THIS DRAWING DESCRIBES A DESIGN CONSIDERED PROPRIETARY IN NATURE, DEVELOPED AND MANUFACTURED BY SWITCHCRAFT INC. AND IS RELEASED ON A CONFIDENTIAL BASIS FOR IDENTIFICATION PURPOSES ONLY.

SIZE	WIDTH	MULT	LBS/M	TEMPER
FINISH		MATERIAL		
SPEC No.		SPEC No.		
FIRST USED ON		SCALE 2:1		
DATE DRAWN	BY	CHKD	APVD	Switchcraft [®]
6/28/16	PNK	PNK 6/28/16	SRC 6/28/16	
NAME HT POWER JACKS L7_2RAH SERIES, RoHS				PART No. L712RAH L722RAH L732RAH
REVISIONS				REV B

CUSTOMER DRAWING