

Tension/compression force transducer

With thin-film technology to 500 kN

Models F2301 standard, F23C1 ATEX, F23S1 safety version

WIKA data sheet FO 51.17



for further approvals,
see page 4

Applications

- Industrial weighing technology
- Machine building and plant construction, manufacturing automation
- Theatre and stage construction
- Chemical and petrochemical industries
- Crane systems and hoists

Special features

- Measuring ranges 0 ... 1 kN to 0 ... 500 kN
[0 ... 224.8 lbf to 0 ... 112,404 lbf]
- Stainless steel version (corrosion-resistant)
- Integrated amplifier
- High long-term stability, high shock and vibration resistance
- Good reproducibility, easy installation



Tension/compression force transducer, model F2301

Description

The tension/compression force transducers are suitable for static and dynamic measuring requirements in the direct force flow. They serve for determining tension and/or compression forces in diverse application areas.

These force transducers are very often used in linear drives as well as in the areas of special machine construction, laboratory technology and stage construction. The force transducers are also perfectly suited for hoists and crane systems. The corresponding technical and regional approvals of these force transducers are, of course, available as options.

The force transducers are made of high-strength, corrosion resistant stainless steel 1.4542, whose properties are particularly suitable for the transducer's application area. As output signals, the common active current and voltage outputs are available (4 ... 20 mA, 0 ... 10 V). Redundant output signals and CAN protocols are possible.

The tension/compression force transducers can be integrated into a certified WIKA overload protection with model ELMS1 (DIN EN ISO 13849-1 with PL d/Cat. 3).

Specifications per VDI/VDE/DKD 2638

Model	F2301	F23S1
Rated force F_{nom} kN	1, 2, 3, 5, 10, 20, 30, 50, 100, 200, 300, 500	3, 5, 10, 20, 30, 50, 100
Rated force F_{nom} lbf	225; 450; 674; 1,124; 2,248; 4,496; 6,744; 11,240; 22,481; 44,962; 67,443; 112,404	674; 1,124; 2,248; 4,496; 6,744; 11,240; 22,481
Relative linearity error $d_{lin}^{1)}$	$\pm 0.5 \% F_{nom}$	
Relative reversibility error v	$< 0.1 \% F_{nom}$	
Temperature effect on		
the characteristic value TK_c	$0.2 \% F_{nom} / 10 \text{ K}$	$0.4 \% F_{nom} / 10 \text{ K}$
the zero signal TK_0	$0.2 \% F_{nom} / 10 \text{ K}$	$0.4 \% F_{nom} / 10 \text{ K}$
Force limit F_L	$150 \% F_{nom}$	
Breaking force F_B	$300 \% F_{nom}$	
Permissible vibration loading F_{rb}	$50 \% F_{nom}$ (in accordance with DIN 50100)	
Rated displacement (typical) s_{nom}		
$< 10 \text{ kN}$ [$< 2,248 \text{ lbf}$]	$< 0.02 \text{ mm}$ [$< 0.00079 \text{ in}$]	
$< 100 \text{ kN}$ [$< 22,481 \text{ lbf}$]	$< 0.2 \text{ mm}$ [$< 0.0079 \text{ in}$]	
Rated temperature range $B_{T, nom}$	$-20 \dots +80 \text{ }^\circ\text{C}$ [$-4 \dots +176 \text{ }^\circ\text{F}$]	
Operating temperature range $B_{T, G}$	<ul style="list-style-type: none"> ■ $-30 \dots +80 \text{ }^\circ\text{C}$ [$-22 \dots +176 \text{ }^\circ\text{F}$] ■ $-40 \dots +80 \text{ }^\circ\text{C}$ [$-40 \dots +176 \text{ }^\circ\text{F}$] 	$-30 \dots +80 \text{ }^\circ\text{C}$ [$-22 \dots +176 \text{ }^\circ\text{F}$]
Storage temperature range $B_{T, S}$	$-40 \dots +85 \text{ }^\circ\text{C}$ [$-40 \dots +185 \text{ }^\circ\text{F}$]	
Electrical connection	<ul style="list-style-type: none"> ■ Circular connector M12 x 1, 5-pin ■ CANopen[®], 5-pin 	2-connector variant, 4-pin
Characteristic value range B_C (Output signal)	<ul style="list-style-type: none"> ■ 4 ... 20 mA, 2-wire ■ 4 ... 20 mA, 3-wire ■ DC 0 ... 10 V, 3-wire ■ Optional redundant signal ■ CANopen[®] <p>Protocol in accordance with CiA[®] 301, instrument profile CiA[®] 404, communication services LSS (CiA[®] 305), configuration of the instrument address and baud rate Sync/Async, Node/Lifeguarding, heartbeat; zero point and span $\pm 10 \%$ adjustable via entries in the object directory ²⁾</p>	<ul style="list-style-type: none"> ■ Redundant, opposing ■ 4 ... 20 mA, 3-wire / 20 ... 4 mA, 3-wire <p>Version in accordance with requirements for functional safety per machinery directive 2006/42/EC.</p>
Insulation resistance	$> 2 \text{ G}\Omega$	
Current/power consumption	<ul style="list-style-type: none"> ■ Current output 4 ... 20 mA 2-wire: Signal current ■ Current output 4 ... 20 mA 3-wire: $< 8 \text{ mA}$ ■ Voltage output: $< 8 \text{ mA}$ ■ CANopen[®]: $< 1 \text{ W}$ 	Current output 4 ... 20 mA: Signal current
Supply voltage U_B	<ul style="list-style-type: none"> ■ DC 9 ... 36 V for current output ■ DC 13 ... 36 V for voltage output ■ DC 9 ... 36 V for CANopen[®] 	DC 10 ... 30 V for current output
Load	<ul style="list-style-type: none"> ■ $\leq (U_B - 10 \text{ V}) / 0.024 \text{ A}$ for current output ■ $> 25 \text{ k}\Omega$ for voltage output 	<ul style="list-style-type: none"> ■ $\leq (U_B - 10 \text{ V}) / 0.020 \text{ A}$ (channel 1) for current output ■ $\leq (U_B - 7 \text{ V}) / 0.020 \text{ A}$ (channel 2) for current output
Ingress protection (per IEC/EN 60529)		IP67
Unplugged state	IP66, IP67	
Plugged-in state	IP68, IP69, IP69K	
Electrical protection	Reverse polarity protection, overvoltage and short-circuit resistance	
Vibration resistance	20 g, 100 h, 50 ... 150 Hz (per DIN EN 60068-2-6)	
Shock resistance	DIN EN 60068-2-27	
Immunity	In accordance with DIN EN 61326-1/DIN EN 61326-2-3 (optional EMC-strengthened versions)	

1) Relative linearity error is specified in accordance with Directive VDI/VDE/DKD 2638 chapter 3.2.6.

2) Protocol in accordance with CiA[®] 301, instrument profile CiA[®] 404, communication service LSS (CiA[®] 305).

CANopen[®] and CiA[®] are registered community trademarks of CAN in Automation e. V.

Specifications per VDI/VDE/DKD 2638

Model	F23C1 ATEX/IECEx EX ib 1)	F2301 Signal jump
Rated force F_{nom} kN	1, 2, 3, 5, 10, 20, 30, 50, 100	
Rated force F_{nom} lbf	225; 450; 674; 1,124; 2,248; 4,496; 6,744; 11,240; 22,481	
Relative linearity error d_{lin} 2)	$\pm 0.5\% F_{nom}$	
Relative reversibility error v	$< 0.1\% F_{nom}$	
Temperature effect on		
the characteristic value TK_C	$0.4\% F_{nom} / 10\text{ K}$	$0.2\% F_{nom} / 10\text{ K}$
the zero signal TK_0	$0.4\% F_{nom} / 10\text{ K}$	$0.2\% F_{nom} / 10\text{ K}$
Force limit F_L	$150\% F_{nom}$	
Breaking force F_B	$300\% F_{nom}$	
Permissible vibration loading F_{rb}	$\pm 50\% F_{nom}$ (in accordance with DIN 50100)	
Rated displacement (typical) s_{nom}		
< 10 kN [$< 2,248\text{ lbf}$]	$< 0.02\text{ mm}$ [$< 0.00079\text{ in}$]	
< 100 kN [$< 22,481\text{ lbf}$]	$< 0.2\text{ mm}$ [$< 0.0079\text{ in}$]	
Rated temperature range $B_{T, nom}$	$-20 \dots +80\text{ }^\circ\text{C}$ [$-4 \dots +176\text{ }^\circ\text{F}$]	
Operating temperature range $B_{T, G}$	Ex II 2G Ex ib IIC T4 Gb $-25\text{ }^\circ\text{C} < T_{amb} < +85\text{ }^\circ\text{C}$ Ex II 2G Ex ib IIC T3 Gb $-25\text{ }^\circ\text{C} < T_{amb} < +100\text{ }^\circ\text{C}$ Ex I M2 Ex ib I Mb $-25\text{ }^\circ\text{C} < T_{amb} < +85\text{ }^\circ\text{C}$ Ex II 2G Ex ib IIC T4 Gb $-40\text{ }^\circ\text{C} < T_{amb} < +85\text{ }^\circ\text{C}$ Ex I M2 Ex ib I Mb	$-30 \dots +80\text{ }^\circ\text{C}$ [$-22 \dots +176\text{ }^\circ\text{F}$]
Storage temperature range $B_{T, S}$	$-40 \dots +85\text{ }^\circ\text{C}$ [$-40 \dots +185\text{ }^\circ\text{F}$]	
Electrical connection	Circular connector M12 x 1, 4-pin	
Characteristic value range B_C (Output signal)	4 ... 20 mA, 2-wire	<ul style="list-style-type: none"> ■ 4 ... 16 mA, 2-wire 3) ■ DC 2 ... 8 V, 3-wire 3)
Insulation resistance	$> 2\text{ G}\Omega$	
Current/power consumption	Current output 4 ... 20 mA 2-wire: Signal current	<ul style="list-style-type: none"> ■ Current output 4 ... 20 mA 2-wire: Signal current ■ Current output 4 ... 20 mA 3-wire: $< 8\text{ mA}$ ■ Voltage output: $< 8\text{ mA}$
Supply voltage UB	DC 10 ... 30 V for current output	<ul style="list-style-type: none"> ■ DC 10 ... 30 V for current output ■ DC 14 ... 30 V for voltage output
Load	<ul style="list-style-type: none"> ■ $\leq (UB - 10\text{ V}) / 0.024\text{ A}$ for current output ■ $> 25\text{ k}\Omega$ for voltage output 	
Ingress protection (per IEC/EN 60529)	IP67	
Electrical protection	Reverse polarity protection, overvoltage and short-circuit resistance	
Vibration resistance	20 g, 100 h, 50 ... 150 Hz (per DIN EN 60068-2-6)	
Immunity	In accordance with DIN EN 61326-1/DIN EN 61326-2-3 (optional EMC-strengthened versions)	

1) The force transducers with ignition protection type "ib" should only be powered using galvanically isolated power inserters.



2) Relative linearity error is specified in accordance with Directive VDI/VDE/DKD 2638 chapter 3.2.6.

3) Other signal jumps are realisable on request.





Options

- Certificates, strength verifications, 3D/CAD files (STEP, IGES) on request

Approvals

Logo	Description	Region
	EU declaration of conformity EMC directive	European Union
	UKCA EMC directive	United Kingdom

Optional approvals

Logo	Description	Region
	ATEX directive ¹⁾ Hazardous areas Ex ib Ex II 2G Ex ib IIC T4 Gb $-25\text{ °C} < T_{\text{amb}} < +85\text{ °C}$ Ex II 2G Ex ib IIC T3 Gb $-25\text{ °C} < T_{\text{amb}} < +100\text{ °C}$ Ex I M2 Ex ib I Mb $-25\text{ °C} < T_{\text{amb}} < +85\text{ °C}$ Ex II 2G Ex ib IIC T4 Gb $-40\text{ °C} < T_{\text{amb}} < +85\text{ °C}$ I M2 Ex ib I Mb ²⁾	European Union
	IECEX ¹⁾ Hazardous areas Ex ib Ex ib IIC T4/T3 Gb $-25\text{ °C} < T_{\text{amb}} < +85\text{ °C}$ Ex ib IIC T4 Gb $-25\text{ °C} < T_{\text{amb}} < +100\text{ °C}$ Ex ib I Mb $-25\text{ °C} < T_{\text{amb}} < +85\text{ °C}$ Ex ib IIC T4 Gb $-40\text{ °C} < T_{\text{amb}} < +85\text{ °C}$	International
	UL Component approval	USA and Canada
	EAC	Eurasian Economic Community

1) Only applies to model F23C1.

2) Only available with cable connection.

Dimensions in mm [in]

Model F2301 version to 30 kN [6,744 lbf]

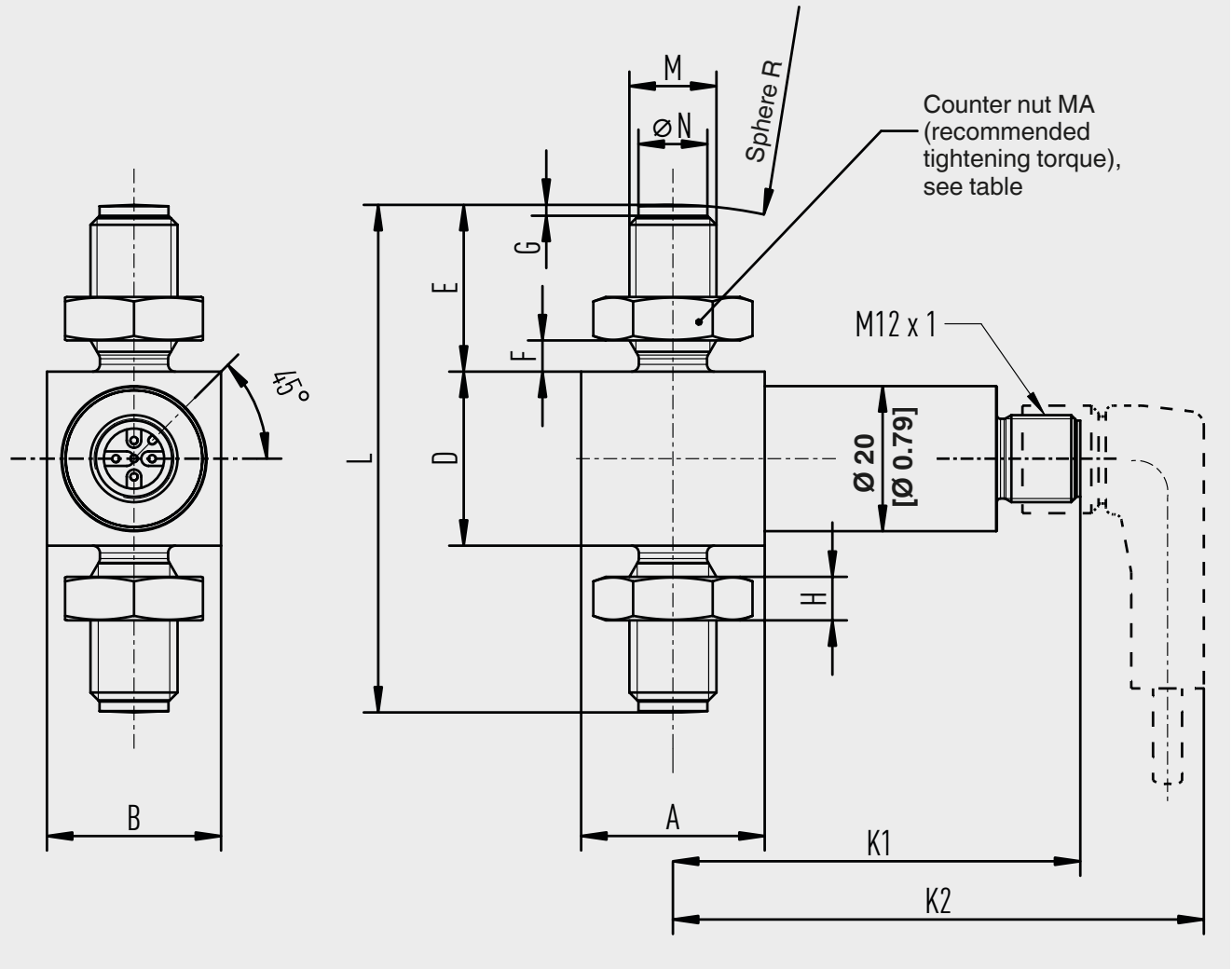

Rated force in kN	Dimensions in mm															MA (Nm)
	A	B	D	E	F	G	H	K1	K2	L	M	ØN -0.1	Sphere R	Rated displacement		
1, 2, 3	25.3	24	24	23	4.3	1.5	6	56	76	70	M12	9.5	60	< 0.02	15	
5	25.3	24	24	23	4.3	1.5	6	56	76	70	M12	9.5	60	< 0.02	15	
10	25.3	24	31	23	4.3	1.5	6	56	76	77	M12	9.5	80	< 0.02	15	
20	25.3	26	35	34	3.8	2	10	56	76	103	M20 x 1.5	17	100	< 0.2	60	
30	26	27	44	34	3.8	2	10	56.5	76.5	112	M20 x 1.5	17	120	< 0.2	60	

Rated force in lbf	Dimensions in inch															MA (Nm)
	A	B	D	E	F	G	H	K1	K2	L	M	ØN -0.0039	Sphere R	Rated displacement		
225, 450, 674	0.99	0.99	0.99	0.9	0.17	0.06	0.24	2.2	2.99	2.75	M12	0.37	2.36	< 0.00079	15	
1,124	0.99	0.99	0.99	0.9	0.17	0.06	0.24	2.2	2.99	2.75	M12	0.37	2.36	< 0.00079	15	
2,248	0.99	0.99	0.99	0.9	0.17	0.06	0.24	2.2	2.99	3.03	M12	0.37	3.15	< 0.00079	15	
4,496	0.99	1	1.37	1.34	0.15	0.08	0.39	2.2	2.99	4.05	M20 x 1.5	0.67	3.94	< 0.0079	60	
6,744	1.02	1.06	1.73	1.34	0.15	0.08	0.39	2.22	3.01	4.41	M20 x 1.5	0.67	4.72	< 0.0079	60	

Dimensions in mm [in]

Model F2301 version from 50 kN [11,240 lbf]

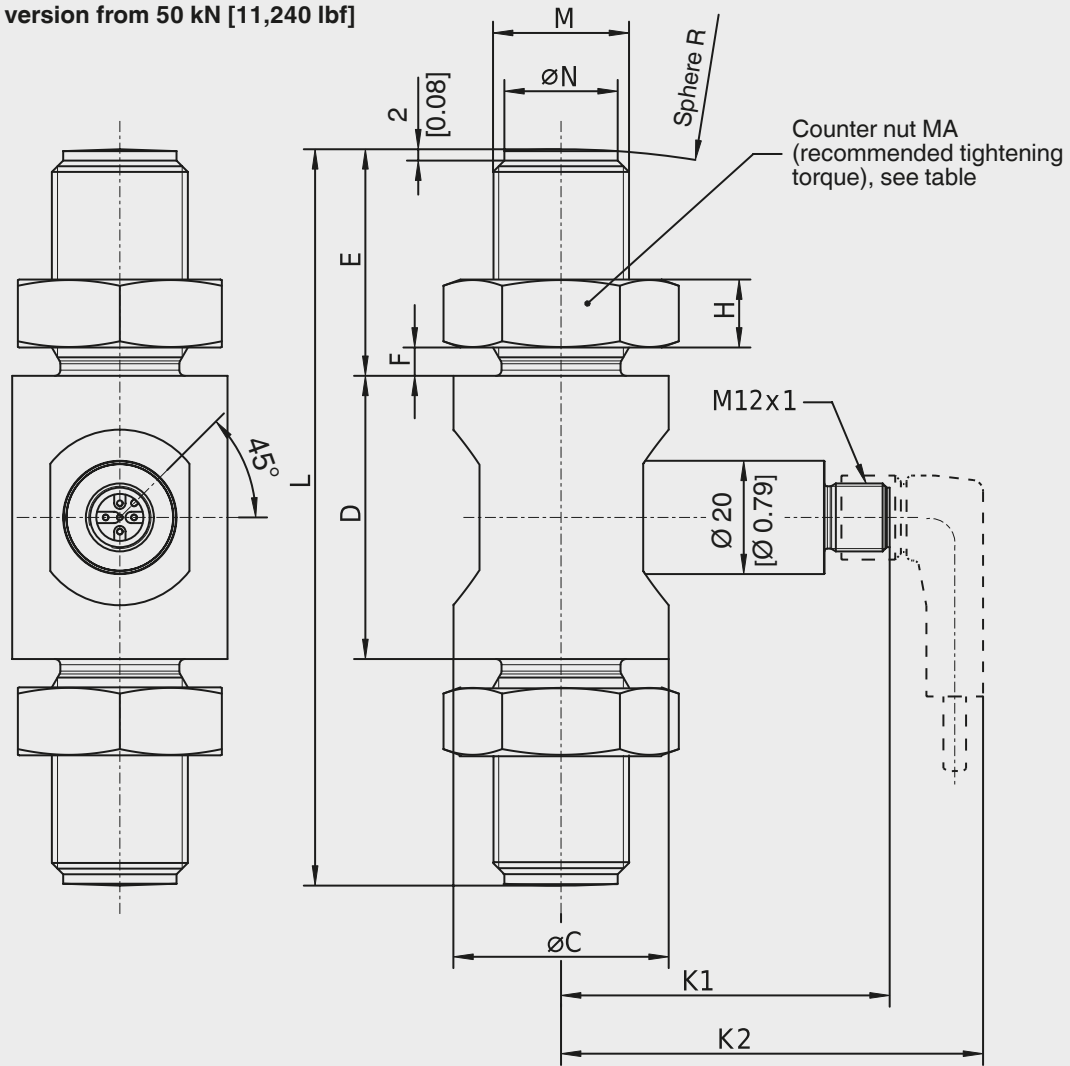

Rated force in kN	Dimensions in mm													MA (Nm)
	$\varnothing C$	D	E	F	G	H	K1	K2	L	M	$\varnothing N_{-0.1}$	Sphere R	Rated displacement	
50	38	50	40	5	2	12	58	68	130	M24 x 2	20	150	< 0.2	110
100	46	54	71	7.5	3	19.5	62.5	82.5	196	M39 x 3	34	200	< 0.2	390
200	67	67	82	7.5	3	22.5	73	93	231	M45 x 3	40	250	< 0.2	495
300	73	73	98	14	3	28	49	69	269	M56 x 4	50	300	< 0.2	640
500	94	94	113	17	3	32	59	79	320	M64 x 4	58	400	< 0.2	760

Rated force in lbf	Dimensions in inch													MA (Nm)
	$\varnothing C$	D	E	F	G	H	K1	K2	L	M	$\varnothing N_{-0.0039}$	Sphere R	Rated displacement	
11,240	1.5	1.97	1.57	0.2	0.08	0.47	2.28	2.68	5.12	M24 x 2	0.79	5.9	< 0.0079	110
22,481	1.81	2.16	2.8	0.3	0.12	0.76	2.46	3.25	7.72	M39 x 3	1.34	7.87	< 0.0079	390
44,962	2.64	2.64	3.23	0.3	0.12	0.88	2.87	3.66	9.09	M45 x 3	1.57	9.84	< 0.0079	495
67,443	2.87	2.87	3.86	0.55	0.12	1.1	1.93	2.72	10.6	M56 x 4	1.97	11.8	< 0.0079	640
112,404	3.7	3.7	4.45	0.67	0.12	1.26	2.32	3.11	12.6	M64 x 4	2.28	15.75	< 0.0079	760

Dimensions in mm [in]

Model F23C1 version to 30 kN [6,744 lbf]

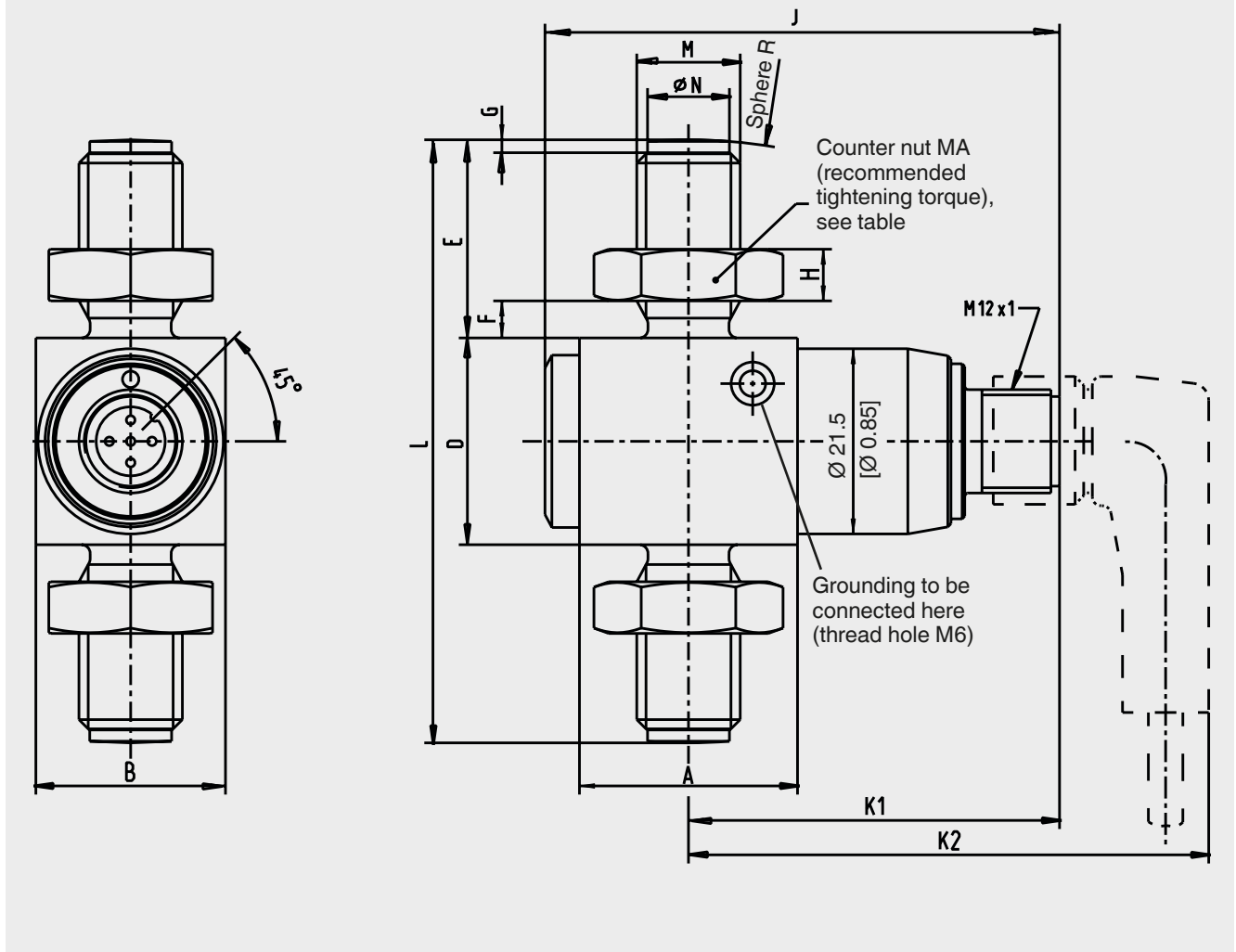

Rated force in kN	Dimensions in mm																MA (Nm)
	A	B	D	E	F	G	H	J	K1	K2	L	M	ØN -0.1	Sphere R	Rated displacement		
1, 2, 3	25.3	22	24	23	4.3	1.5	6	59.7	43	63	70	M12	9.5	60	< 0.02	15	
5	25.3	22	24	23	4.3	1.5	6	59.7	43	63	70	M12	9.5	60	< 0.02	15	
10	25.3	22	31	23	4.3	1.5	6	59.7	43	63	77	M12	9.5	80	< 0.02	15	
20	25.3	26	33	34	3.8	2	10	59.7	43	63	101	M20 x 1.5	17	100	< 0.2	60	
30	27.6	27.5	40	34	3.8	2	10	61.5	44	64	108	M20 x 1.5	17	120	< 0.2	60	

Rated force in lbf	Dimensions in inch																MA (Nm)
	A	B	D	E	F	G	H	J	K1	K2	L	M	ØN -0.0039	Sphere R	Rated displacement		
225, 450 674	0.99	0.87	0.99	0.9	0.17	0.06	0.24	2.35	1.7	2.48	2.75	M12	0.37	2.36	< 0.00079	15	
1,124	0.99	0.87	0.99	0.9	0.17	0.06	0.24	2.35	1.7	2.48	2.75	M12	0.37	2.36	< 0.00079	15	
2,248	0.99	0.87	0.99	0.9	0.17	0.06	0.24	2.35	1.7	2.48	3.03	M12	0.37	3.15	< 0.00079	15	
4,496	0.99	1	1.3	1.34	0.15	0.08	0.39	2.35	1.7	2.48	3.98	M20 x 1.5	0.67	3.94	< 0.0079	60	
6,744	1.09	1.08	1.57	1.34	0.15	0.08	0.39	2.42	1.73	2.52	4.25	M20 x 1.5	0.67	4.72	< 0.0079	60	

Dimensions in mm [in]

Model F23C1 version from 50 kN [11,240 lbf]

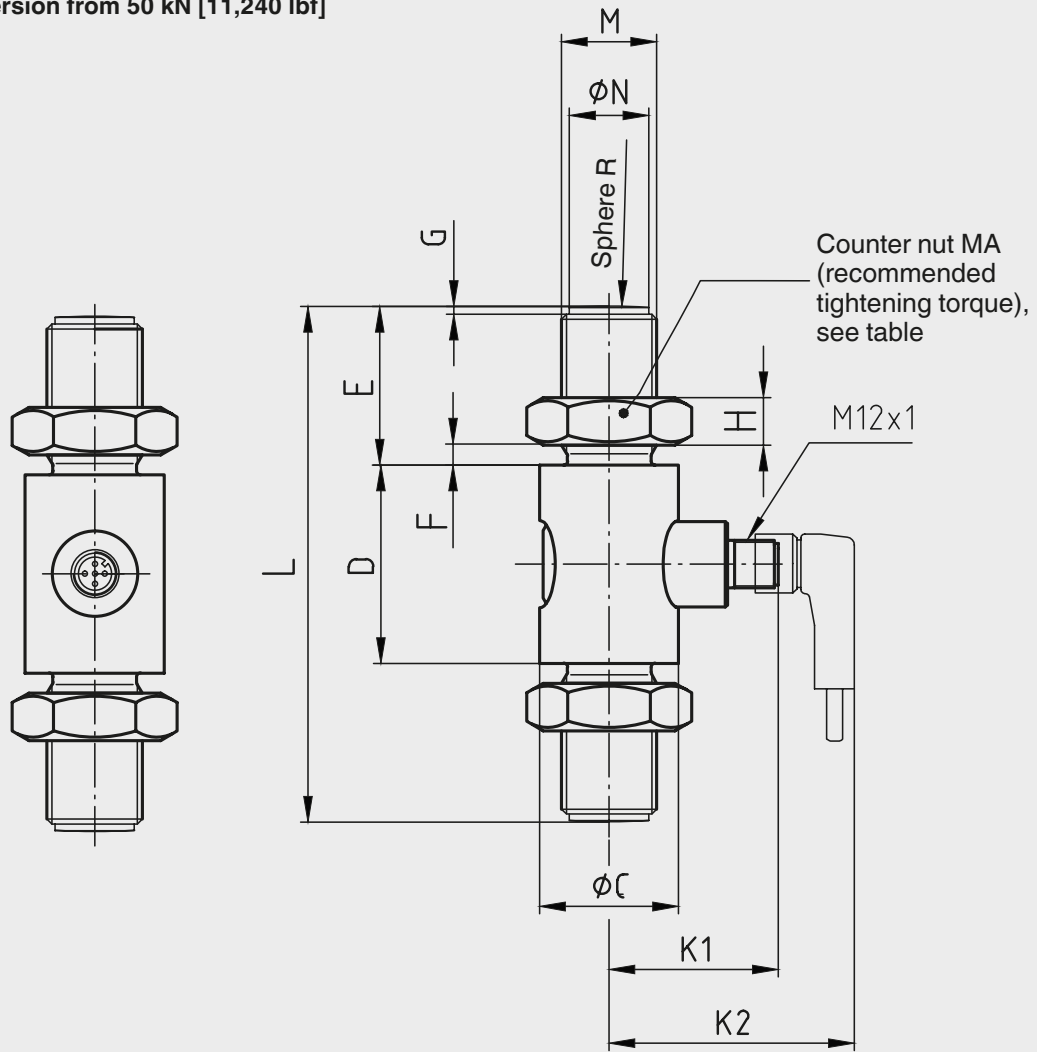

Rated force in kN	Dimensions in mm													MA (Nm)
	ØC	D	E	F	G	H	K1	K2	L	M	ØN _{-0.1}	Sphere R	Rated displacement	
50	35	50	40	5	2	12	43	62	130	M24 x 2	20	150	< 0.2	110
100	54	54	68	10	3	19.5	44	64	190	M39 x 3	34	200	< 0.2	390
200	67	67	82	12	3	22.5	45	65	231	M45 x 3	40	250	< 0.2	495
300	73	73	98	14	3	28	49	69	269	M56 x 4	50	300	< 0.2	640
500	94	94	113	17	3	32	59	79	320	M64 x 4	58	400	< 0.2	760

Rated force in lbf	Dimensions in inch													MA (Nm)
	ØC	D	E	F	G	H	K1	K2	L	M	ØN _{-0.0039}	Sphere R	Rated displacement	
11,240	1.38	1.97	1.57	0.2	0.08	0.47	1.7	2.44	5.12	M24 x 2	0.79	5.9	< 0.0079	110
22,481	2.16	2.16	2.68	0.39	0.12	0.76	1.73	2.52	7.48	M39 x 3	1.34	7.87	< 0.0079	390
44,962	2.64	2.64	3.23	0.47	0.12	0.88	1.77	2.56	9.09	M45 x 3	1.57	9.84	< 0.0079	495
67,443	2.87	2.87	3.86	0.55	0.12	1.1	1.93	2.72	10.6	M56 x 4	1.97	11.8	< 0.0079	640
112,404	3.7	3.7	4.45	0.67	0.12	1.26	2.32	3.11	12.6	M64 x 4	2.28	15.75	< 0.0079	760

Dimensions in mm [in]

Model F2301 with signal jump, version to 30 kN [6,744 lbf]

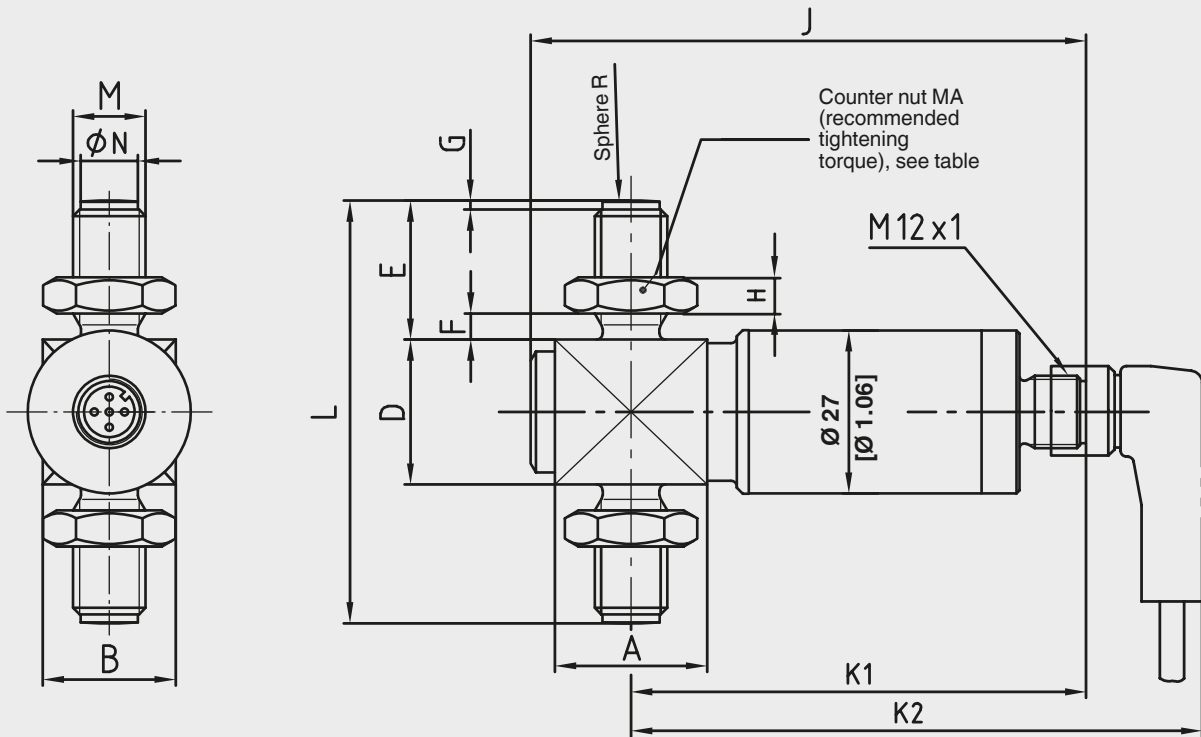

Rated force in kN	Dimensions in mm															MA (Nm)
	A	B	D	E	F	G	H	J	K1	K2	L	M	N _{-0.1}	Sphere R		
5	25.2	22	24	23	4.3	1.5	6]	89	72	91.5	70	M12	9.5	60	15	
10	25.2	22	31	23	4.3	1.5]	6	89	72]	91.5	77	M12	9.5	80	15	
20	25.2	26	33	34	3.8]	2	10	91.5	73	91.5	101	M20 x 1.5	17	100	60	
30	27.5	27.5	40	34	3.8	2	10	91.5	73	92.5	108	M20 x 1.5	17	120	60	

Rated force in lbf	Dimensions in inch															MA (Nm)
	A	B	D	E	F	G	H	J	K1	K2	L	M	ØN _{-0.0039}	Sphere R		
1,124	0.99	0.87	0.94	0.9	0.17	0.06	0.24	3.5	2.83	3.6	2.75	M12	0.37	2.36	15	
2,248	0.99	0.87	1.22	0.9	0.17	0.06	0.24	3.5	2.83	3.6	3.03	M12	0.37	3.15	15	
4,496	0.99	1.02	1.3	1.34	0.15	0.08	0.39	3.6	2.87	3.6	3.98	M20 x 1.5	0.67	3.94	60	
6,744	1.08	1.08	1.57	1.34	0.15	0.08	0.39	3.6	2.87	3.6	4.25	M20 x 1.5	0.67	4.72	60	

Dimensions in mm [in]

Model F2301 with signal jump, version to 50 kN [11,240 lbf]

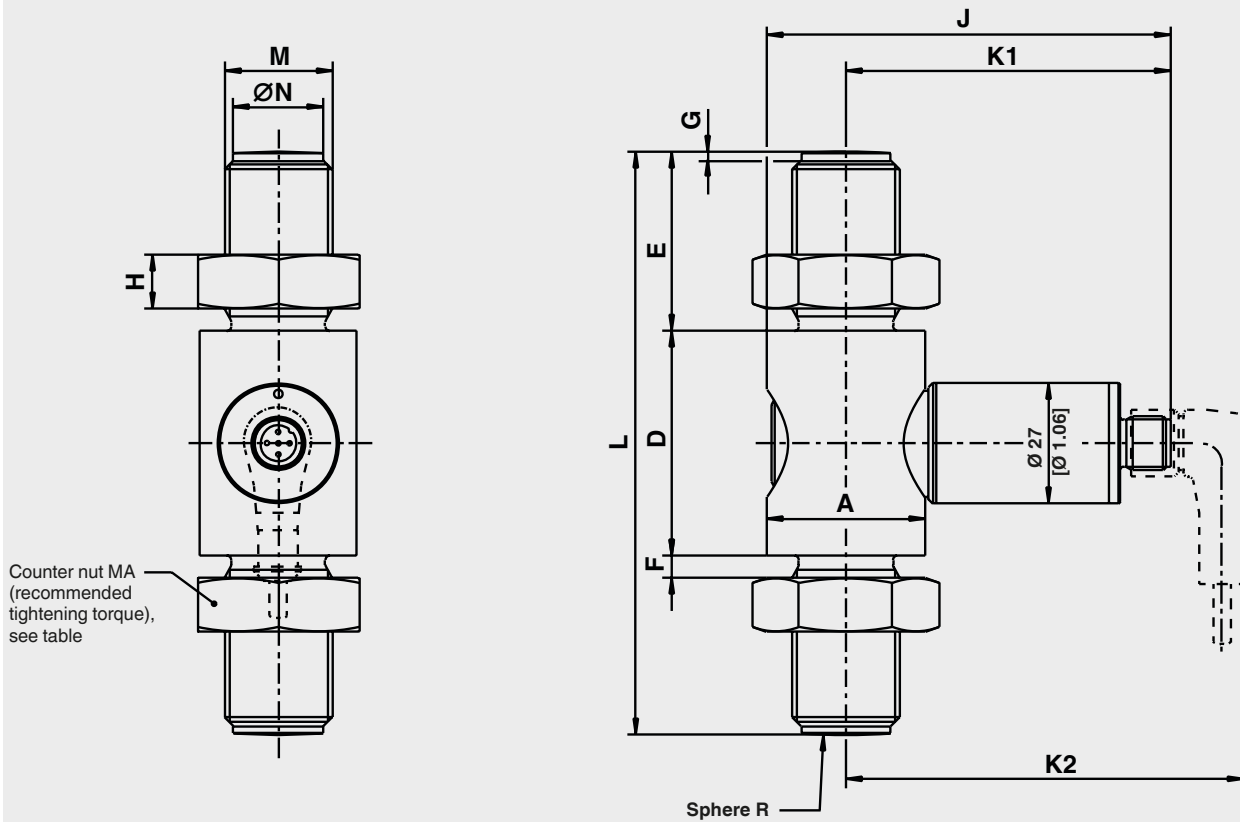

Rated force in kN	Dimensions in mm														MA (Nm)
	ØA	D	E	F	G	H	J	K1	K2	L	M	Ø N _{-0.1}	Sphere R	Rated displacement	
50	35	50	40	5	2	12	91.5	73	90.2	130	M24 x 2	20	150	< 0.2	110
100	54	54	68	10	3.7	19.5	91.5	71	91	197	M39 x 3	34	200	< 0.2	390

Rated force in lbf	Dimensions in inch														MA (Nm)
	ØA	D	E	F	G	H	J	K1	K2	L	M	ØN _{-0.0039}	Sphere R	Rated displacement	
11,240	1.38	1.97	1.57	0.2	0.08	0.47	3.6	2.87	3.55	5.12	M24 x 2	0.79	5.9	< 0.0079	110
22,481	2.16	2.16	2.68	0.39	0.15	0.76	3.6	2.79	3.58	7.75	M39 x 3	1.34	7.87	< 0.0079	390

Dimensions in mm [in]

Model F23S1 version from 3 kN [674 lbf]

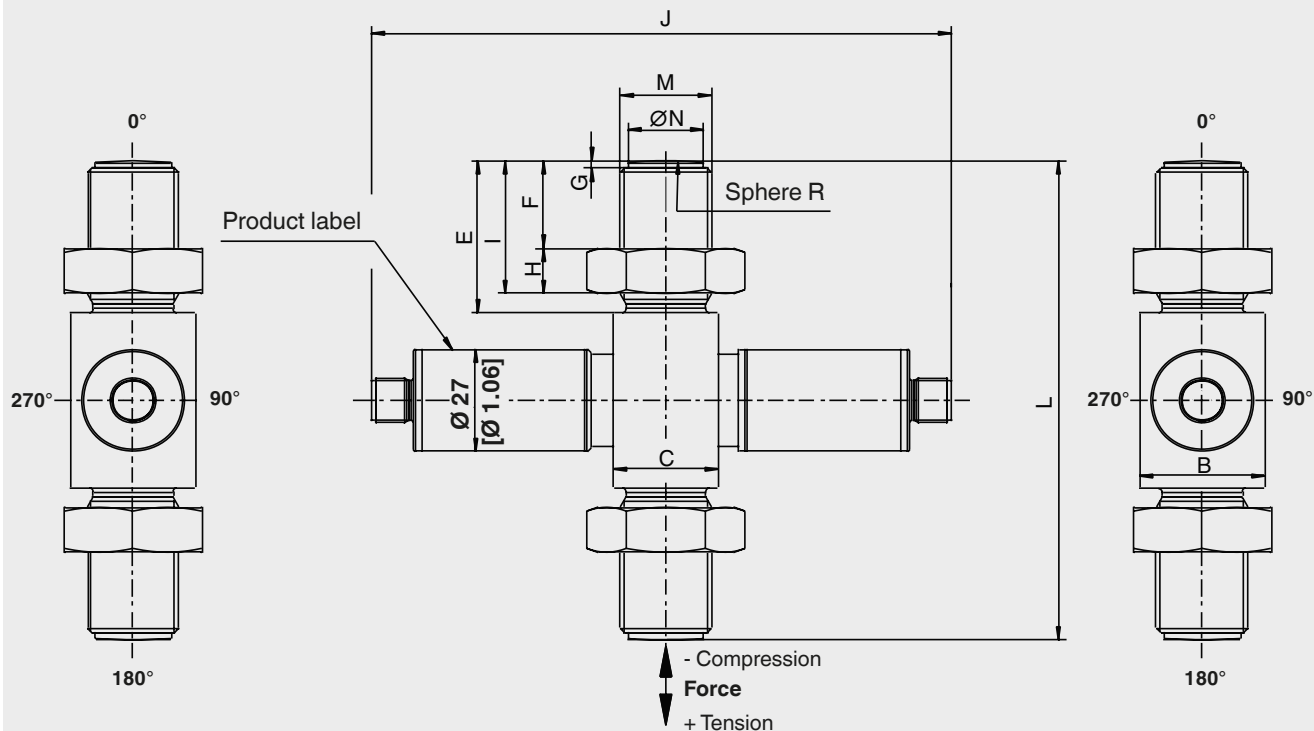

Rated force in kN	Dimensions in mm											
	B	C	E	F	G	H	I	J	L	M	Ø N -0.1	Sphere R
3-7	22	25.3	23	12.7	1.5	6	18.7	152.5	75	M12	9.5	60
6-13	25.3	25.3	26	13.5	1.5	8	21.5	152.5	85	M16 x 1.5	13	80
12-26	27.5	27.6	34	20.2	2	10	30.2	152.5	108	M20 x 1.5	17	120
18-40	33	27.6	40	23	2	12	35	152.5	126	M24 x 2	20	120
31-70	40	40	48	25	2	15	40	157.4	154	M30 x 2	26	150
67-151	60	60	78	47.8	3	19.7	67.5	177.4	223	M42 x 2	38	250

Rated force in lbf	Dimensions in inch											
	B	C	E	F	G	H	I	J	L	M	Ø N _{-0.0039}	Sphere R
674.48-1,574	0.87	0.99	0.9	0.5	0.06	0.27	0.736	6	2.95	M12	0.37	2.36
1,349-2,923	0.99	0.99	1	0.53	0.06	0.315	0.85	6	3.35	M16 x 1.5	0.51	3.15
2,698-5,845	1.08	1.09	1.34	0.79	0.079	0.39	1.19	6	4.25	M20 x 1.5	0.67	4.72
4,047-8,992	1.3	1.09	1.57	0.9	0.079	0.47	1.38	6	4.96	M24 x 2	0.79	4.72
6,969-15,737	1.57	1.57	1.89	0.98	0.079	0.59	1.57	6.2	6.06	M30 x 2	1.02	5.9
15,062-33,946	2.36	2.36	3.07	1.88	0.19	0.78	2.66	6.98	8.78	M42 x 2	1.5	9.84

Dimensions in mm [in]

Accessory: Swivel heads in accordance with DIN ISO 12240-4

Ø -D1 = 12 ... 25 mm [0.47 ... 0.98 in] - dimension range K

Ø -D2 = 40 ... 80 mm [1.57 ... 3.15 in] - dimension range E

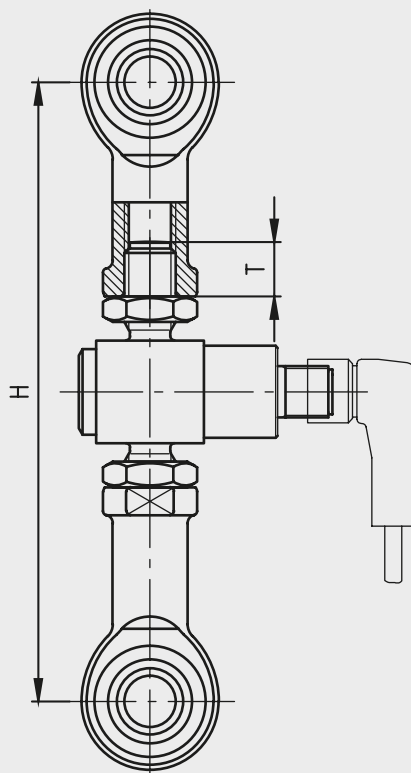
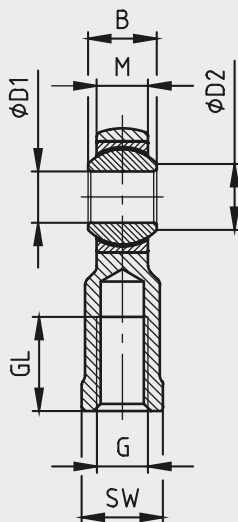
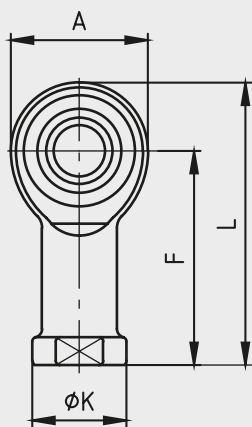

Rated force in kN	Dimensions in mm													Weight in kg
	A	B	ØD ₁	ØD ₂	F	G	GL	H	ØK	L	M	SW	T	
1, 2, 3, 5	32	16	12 H7	15.4	50	M12	22	148 ±3	22	55	12	19	9.5	0.115
10	32	16	12 H7	15.4	50	M12	22	155 ±3	22	55	12	19	9.5	0.115
20	50	25	20 H7	24.3	77	M20 x 1.5	33	219 ±4	34	102	18	32	16	0.415
30	50	25	20 H7	24.3	77	M20 x 1.5	33	226 ±4	34	102	18	32	16	0.415
50	60	31	25 H7	29.6	94	M24 x 2	42	276 ±4	42	124	22	36	19.5	0.750
100	92]	28	40 _{-0.012}	45	142	M39 x 3	65	405 ±7	65	188	23	55	31	2
200	112	35	50 _{-0.012}	56	160	M45 x 3	68	466 ±13	75	216	30	65	36	3.5
300	160	49	70 _{-0.015}	77.9	200	M56 x 4	80	568 ±11	98	280	42	85	45	8.6
500	180	55	80 _{-0.015}	89.4	230	M64 x 4	85	665 ±13	110	320	47	100	51	12

Rated force in lbf	Dimensions in inch													Weight in lbs
	A	B	ØD ₁	ØD ₂	F	G	GL	H	ØK	L	M	SW	T	
225, 450, 674, 1,124	1.26	0.63	0.47 H7	0.61	1.97	M12	0.87	5.83 ±0.12	0.87	2.16	0.47	0.75	0.37	0.115 0.254
2,248	1.26	0.63	0.47 H7	0.61	1.97	M12	0.87	6.10 ±0.12	0.87	2.16	0.47	0.75	0.37	0.254
4,496	1.97	0.98	0.79 H7	0.96	3.03	M20 x 1.5	1.3	8.62 ±0.16	1.34	4.02	0.71	1.26	0.63	0.915
6,744	1.97	0.98	0.79 H7	0.96	3.03	M20 x 1.5	1.3	8.88 ±0.16	1.34	4.02	0.71	1.26	0.63	0.915
11,240	2.36	1.22	0.98 H7	1.16	3.7	M24 x 2	1.65	10.87 ±0.16	1.65	4.88	0.87	1.42	0.77	1.653
22,481	3.62	1.10	1.57 _{-0.0005}	1.77	5.59	M39 x 3	2.56	15.94 ±0.28	2.56	7.4	0.9	2.16	1.22	4.41
44,962	4.41	1.38	1.97 _{-0.0005}	2.2	6.3	M45 x 3	2.68	18.35 ±0.51	2.95	8.5	1.18	2.56	1.48	7.72
67,443	6.3	1.93	2.75 _{-0.0006}	3.07	7.87	M56 x 4	3.15	22.36 ±0.43	3.86	11	1.65	3.35	1.77	18.96
112,404	7.09	2.16	3.15 _{-0.0006}	3.52	9.05	M64 x 4	3.35	26.18 ±0.51	4.33	12.6	1.85	3.94	2.01	26.45

Pin assignment of analogue output

Abbreviations, definitions

Signal	Description
UB	Voltage source for sensor
UB+	Sensor-supply voltage (+)
UB-	Sensor-supply voltage (-)
S+	Output signal (+)
S-	Output signal (-)
0V	0V-Potential

Signal	Description
(A)	Ammeter
(V)	Voltmeter
(+)	Voltage source
—	Switch
(⊕)	Shield [grounding]

Output 4...20 mA, 2-wire

Connector M12 x 1, 5-pin

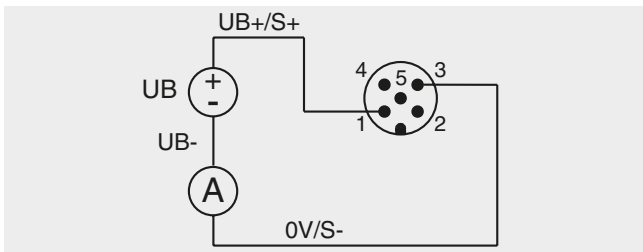

Signal	4 ... 20 mA, 2-wire	Cable colour
UB+/S+	1	Brown
0V/S-	3	Black
Shield (⊕)	Case / connector	--

Cable colours only apply when using the WIKA standard cable, e.g. item no.: 14259454

Output 4...20 mA, 3-wire

Connector M12 x 1, 5-pin

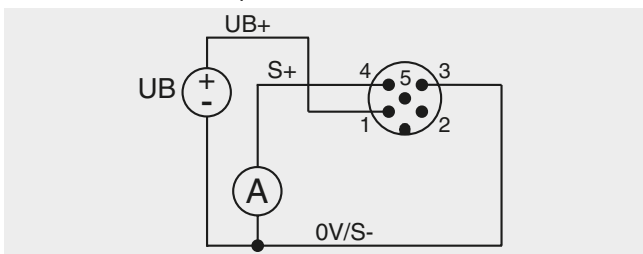

Signal	4 ... 20 mA, 3-wire	Cable colour
UB+	1	Brown
S+	4	Black
0V/S-	3	Blue
Shield (⊕)	Case / connector	--

Cable colours only apply when using the WIKA standard cable, e.g. item no.: 14259454

Output 0...10 V, 3-wire

Connector M12 x 1, 5-pin

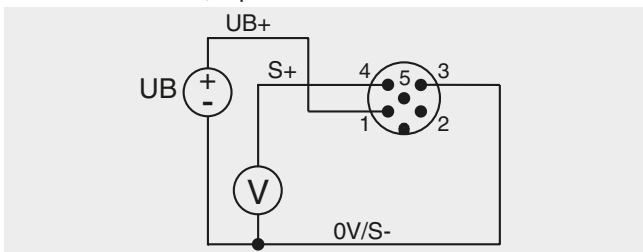

Signal	0 ... 10 V, 3-wire	Cable colour
UB+	1	Brown
S+	4	Black
0V/S-	3	Blue
Shield (⊕)	Case / connector	--

Cable colours only apply when using the WIKA standard cable, e.g. item no.: 14259454

Output 4...20 mA, 2-wire for ATEX Ex ib

Connector M12 x 1, 4-pin

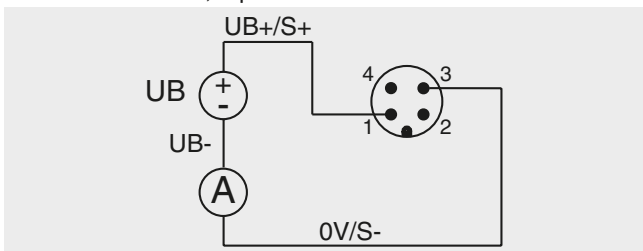

Signal	ATEX/IECEX Ex d 4 ... 20 mA, 2-wire	Cable colour
UB+/S+	1	Brown
0V/S-	3	Blue
Shield (⊕)	Case / connector	--

Cable colours only apply when using the WIKA standard cable, e.g. item no.: 14259454

Abbreviations, definitions

Signal	Description
UB	Voltage source for sensor
UB+	Sensor-supply voltage (+)
UB-	Sensor-supply voltage (-)
UR	Voltage source for den signal jump
UR+	Signal jump-supply voltage (+)
UR-	Signal jump-supply voltage (-)
S+	Output signal (+)
S-	Output signal (-)
0V	0V-Potential

Signal	Description
(A)	Ammeter
(V)	Voltmeter
(+)	Voltage source
⌵	Switch
(⊕)	Shield [grounding]

Output 4 ... 20 mA, 2-wire with signal jump

Circular connector M12 x 1, 4-pin

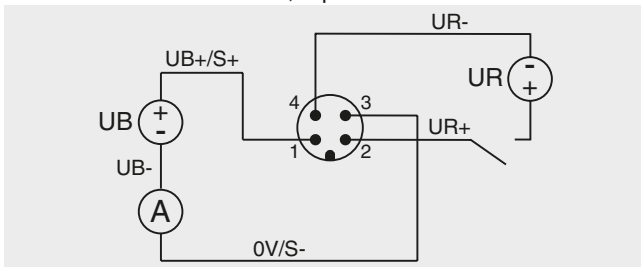

Signal	4 ... 20 mA, 2-wire	Cable colour
UB+/S+	1	Brown
0V/S-	3	Blue
UR+	2	White
UR-	4	Black
Shield (⊕)	Case / connector	--

Cable colours only apply when using the WIKA standard cable, e.g. item no.: 14259454

Output 4 ... 20 mA, 3-wire with signal jump

Circular connector M12 x 1, 4-pin

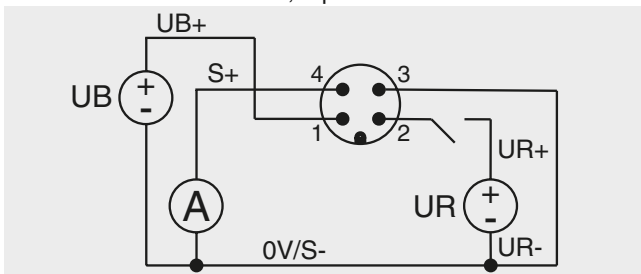

Signal	4 ... 20 mA, 3-wire	Cable colour
UB+	1	Brown
0V/S-	3	Blue
UR+	2	White
UR-	3	Blue
S+	4	Black
Shield (⊕)	Case / connector	--

Cable colours only apply when using the WIKA standard cable, e.g. item no.: 14259454

Output 0...10 V, 3-wire with signal jump

Circular connector M12 x 1, 4-pin

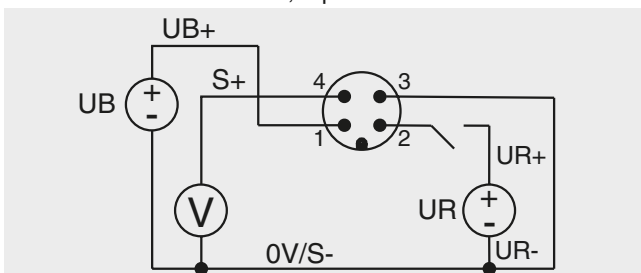

Signal	0 ... 10 V, 3-wire	Cable colour
UB+	1	Brown
0V/S-	3	Blue
UR+	2	White
UR-	3	Blue
S+	4	Black
Shield (⊕)	Case / connector	--

Cable colours only apply when using the WIKA standard cable, e.g. item no.: 14259454

Abbreviations, definitions

Signal	Description
UB	Voltage source for sensor
UB+	Sensor-supply voltage (+)
UB-	Sensor-supply voltage (-)
UR	Voltage source for den signal jump
UR+	Signal jump-supply voltage (+)
UR-	Signal jump-supply voltage (-)
S+	Output signal (+)
S-	Output signal (-)
CH1	Channel1
CH2	Channel2
CH1+2	Channel1 und channel2
0V	0V-Potential

Signal	Description
A	Ammeter
V	Voltmeter
+	Voltage source
—	Switch
⊕	Shield [grounding]

Output 4 ... 20 mA, 2-wire redundant with 1x connector

Circular connector M12 x 1, 5-pin

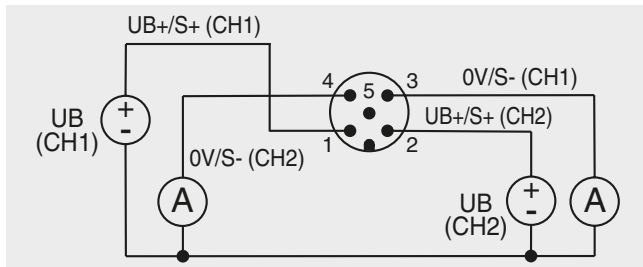

Signal	4 ... 20 mA, 2-wire	Cable colour
UB+/S+ (CH1)	1	Brown
UB+/S+ (CH2)	2	White
0V/S- (CH1)	3	Blue
0V/S- (CH2)	4	Black
Shield ⊕	Case / connector	--

Cable colours only apply when using the WIKA standard cable, e.g. item no.: 14259454

Output 4 ... 20 mA, 3-wire redundant with 1 connector

Circular connector M12 x 1, 5-pin

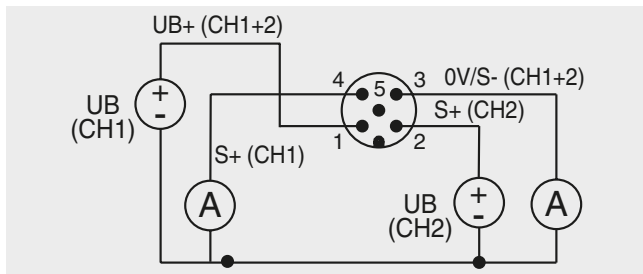

Signal	4 ... 20 mA, 3-wire	Cable colour
UB+ (CH1+2)	1	Brown
0V/S- (CH1+2)	3	Blue
S+ (CH1)	4	Black
S+ (CH2)	2	White
Shield ⊕	Case / connector	--

Cable colours only apply when using the WIKA standard cable, e.g. item no.: 14259454

Output 0...10 V, 3-wire redundant with 1 connector

Circular connector M12 x 1, 5-pin

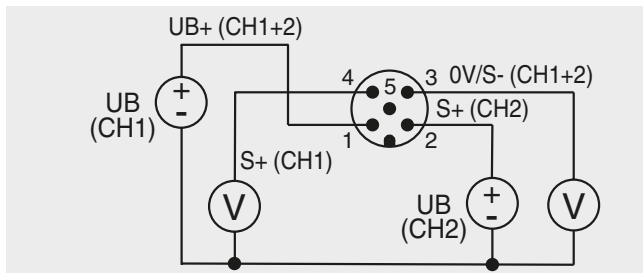

Signal	0 ... 10 V, 3-wire	Cable colour
UB+ (CH1+2)	1	Brown
0V/S- (CH1+2)	3	Blue
S+ (CH1)	4	Black
S+ (CH2)	2	White
Shield ⊕	Case / connector	--

Cable colours only apply when using the WIKA standard cable, e.g. item no.: 14259454

Abbreviations, definitions

Signal	Description
UB	Voltage source for sensor
UB+	Sensor-supply voltage (+)
UB-	Sensor-supply voltage (-)
S+	Output signal (+)
S-	Output signal (-)
CH1	Channel1
CH2	Channel2
CH1+2	Channel1 und channel2
0V	0V-Potential

Signal	Description
(A)	Ammeter
(V)	Voltmeter
(+)	Voltage source
⌵	Switch
(⊕)	Shield [grounding]

Output 4 ... 20 mA, 3-wire redundant opposing with 2x connectors

Circular connector M12 x 1, 4-pin

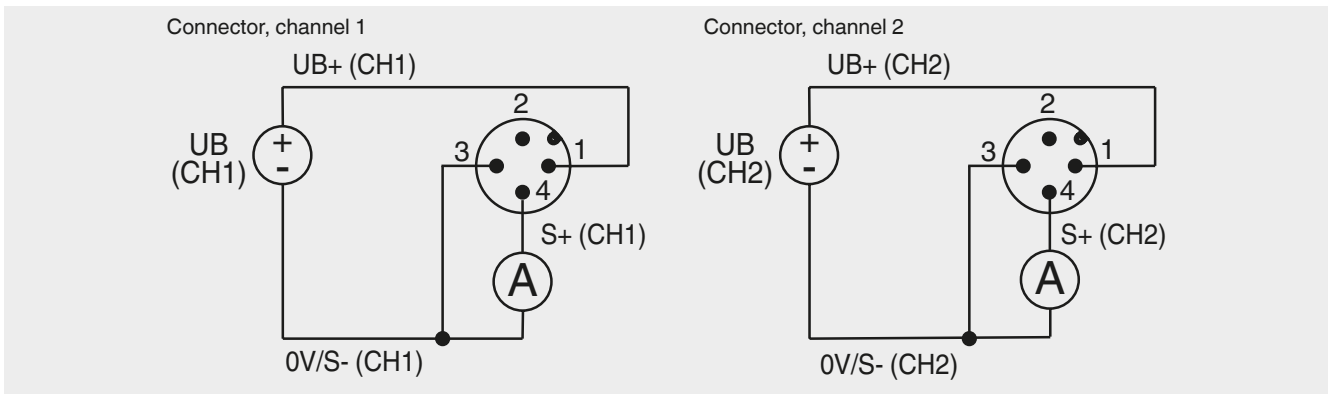

Circular connector M12 x 1, 4-pin

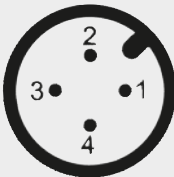

4 ... 20 mA, 3-wire redundant opposing

Signal	Connector, channel 1	Connector, channel 2	Cable colour
UB+	1	1	Brown
0V/S-	3	3	Blue
S+	4	4	Black
Shield (⊕)	Case / connector	Case / connector	--

Cable colours only apply when using the WIKA standard cable, e.g. item no.: 14259454

2-connector variant, e.g. in combination with ELMS1 overload protection (F23S1).

Version in accordance with requirements for functional safety per machinery directive 2006/42/EC.

Pin assignment for CANopen®

Abbreviations, definitions

Signal	Description
CAN-SHLD, Shield Ⓟ	CAN Shield
CAN-V+	CAN external positive voltage supply for the supply of the sensor
CAN-GND	CAN external 0V Potential for the supply of the sensor
CAN-High	CAN_H Bus line (dominant high)
CAN-Low	CAN_L Bus line (dominant low)

Output CANopen® in according to CiA®303-1

Circular connector M12 x 1, 5-pin

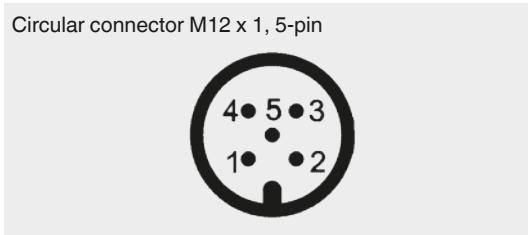

Signal	Pin	Cable colour
CAN-SHLD, Shield Ⓟ	1 / Case / connector	Brown
CAN-V+	2	Blue
CAN-GND	3	White
CAN-High	4	Blue
CAN-Low	5	Black

Cable colours only apply when using the WIKA standard cable, e.g. item no.: 14259454

Connect the cable shield to the case of the force transducer.

In the cables of the accessories, the cable shield is connected by means of the knurled nut, thus connecting it to the case of the force transducer. When using extensions, only shielded and low-capacitance cables should be used.

The permitted maximum and minimum lengths of cable are defined in ISO 11898-2. Care should also be taken with the shielding to ensure a high-quality connection.

Short description of the signal jump electronics

Amplifier electronics 4 ... 20 mA or 0 ... 10 V for signal jump applications with 2-channel computer control

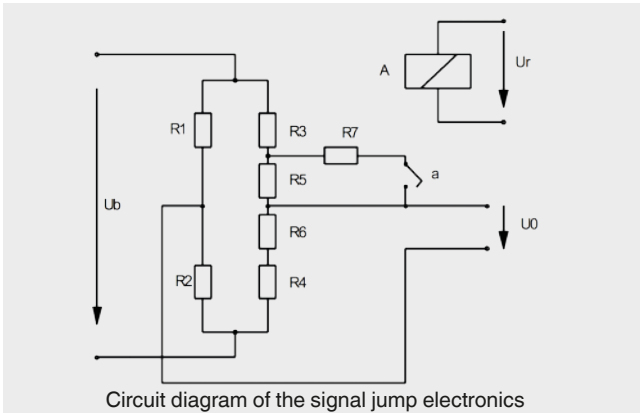

With these force transducers, four variable resistors ($R1 \dots R4$) are connected together to form a Wheatstone bridge. When the measuring body deforms, the opposing resistors are stretched or compressed in the same way. This leads to a detuning of the bridge and a diagonal voltage U_0 .

The test resistor $R7$ is now important in connection with checking the subsequent amplifier circuit and the subsequent signal paths. This is switched parallel to the resistor $R5$ via the relay contact (a) as soon as the excitation voltage U_r of the relay A is present. The connection of the resistor $R7$ causes a defined, always constant, detuning of the zero point (diagonal voltage) of the Wheatstone bridge.

Compliance with functional safety

An external safety control system independent of the force transducer must monitor the safe functioning of the force transducer. The functional test with a signal jump of 4 mA / 2 V is executed at an interval of 24 hours. The safety control system activates the relay A, thus changing the output signal of the force transducer in a defined manner.

If the expected change in the output signal occurs, it can be assumed that the entire signal path from the Wheatstone bridge via the amplifier through to the output is functioning correctly. If this does not occur, then it can be concluded that there is an error in the signal path.

Moreover, the measuring signal should be checked by the safety control for the min. (A) and max. (B) signal value to ensure that any cable break or short-circuit that has occurred is detected.



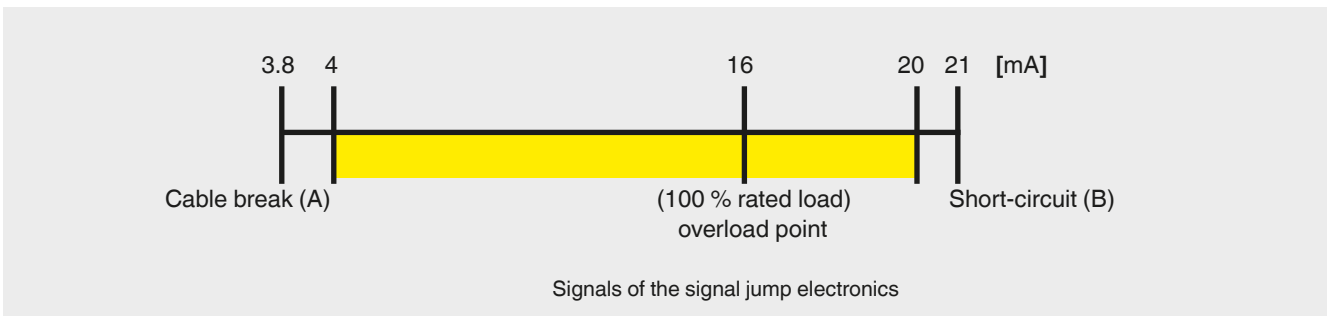

The default setting of the force transducer with current output 4 ... 20 mA for overload detection is, for example:



With a fixed signal jump of, for example, 4 mA, the test cycle can then be triggered, in any operating state, by activating the test relay. The upper measuring range limit of 20 mA will

never be reached and thus the checking of the signal jump is enabled.

Accessories

Connectors model EZE53 with moulded cable					
Model	Description	Temperature range	Cable diameter	Cable length	Order number
	Straight version, cut to length, 4-pin, PUR cable, UL listed, IP67	-20 ... +80 °C [-4 ... +176 °F]	Ø4.75 mm - Ø5.7 mm [Ø0.18 in - Ø0.22 in]	2 m [6.6 ft]	14259451
				5 m [16.4 ft]	14259453
				10 m [32.8 ft]	14259454
	Straight version, cut to length, 5-pin, PUR cable, UL listed, IP67	-20 ... +80 °C [-4 ... +176 °F]	Ø4.75 mm - Ø5.7 mm [Ø0.18 in - Ø0.22 in]	2 m [6.6 ft]	14259458
				5 m [16.4 ft]	79100672
				10 m [32.8 ft]	14259472
	Angled version, cut to length, 4-pin, PUR cable, UL listed, IP67	-20 ... +80 °C [-4 ... +176 °F]	Ø5.05 mm - Ø6 mm [Ø0.2 in - Ø0.24 in]	2 m [6.6 ft]	14259452
				5 m [16.4 ft]	14293481
				10 m [32.8 ft]	14259455
	Angled version, cut to length, 5-pin, PUR cable, UL listed, IP67	-20 ... +80 °C [-4 ... +176 °F]	Ø5.05 mm - Ø6 mm [Ø0.2 in - Ø0.24 in]	2 m [6.6 ft]	79101493
				5 m [16.4 ft]	79100686
				10 m [32.8 ft]	On request

Other cable lengths and cable types are available on request.

Ordering information

To order the described product the order number is sufficient.

© 10/2018 WIKA Alexander Wiegand SE & Co. KG, all rights reserved.

The specifications given in this document represent the state of engineering at the time of publishing.

We reserve the right to make modifications to the specifications and materials.

In case of a different interpretation of the translated and the English data sheet, the English wording shall prevail.

WIKA data sheet FO 51.17 · 07/2023

Page 19 of 19

