

TS3DV642 12-Channel 1:2 MUX/DEMUX with 1.8 V Compatible Control and Power-Down Mode

1 Features

- Switch Type: 2:1 or 1:2
- Dynamic Characteristics
 - Differential Bandwidth (–3 dB)
 - Port A: 6.9 GHz Typical
 - Port B: 7.5 GHz Typical
 - Crosstalk (at 1.7 GHz): –40 dB
 - Isolation (at 1.7 GHz): –23 dB
 - Insertion Loss (DC)
 - Port A: –0.75 dB
 - Port B: –1.0 dB
 - Return Loss (at 1.7 GHz): –15.9 dB
 - Intra-Pair (Bit-Bit) Skew
 - Port A: 2 ps
 - Port B: 6 ps
 - R_{ON}
 - Port A: 6.5 Ω
 - Port B: 8.2 Ω
 - C_{ON} at 1 GHz: 0.5 pF (Typical)
- V_{CC} Range: 2.6 V to 4.5 V
- I/O Voltage Range: 0 V to 5 V
- Special Features
 - I_{OFF} Protection Prevents Current Leakage in Powered Down State ($V_{CC} = 0$ V)
- ESD Performance
 - 2-kV Human Body Model (A114B, Class II)
 - 1-kV Charged Device Model (C101)
- 42-pin WQFN Package (9 mm x 3.5 mm, 0.5 mm pitch)

2 Applications

- HDMI 2.0 With Support for 4k2k up to 60 Hz
- DVI 1.0 Signal Switching
- DisplayPort 1.4 Signal Switching
- General Purpose TMDS Signal Switching
- General Purpose LVDS Signal Switching
- General Purpose High-Speed Signal Switching

3 Description

The TS3DV642 is a 12 channel 1:2 or 2:1 bi-directional multiplexer/demultiplexer. The TS3DV642 operates from a 2.6 V to 4.5 V supply, making it suitable for battery-powered applications. It offers low and flat on-state resistance (R_{ON}) as well as low I/O capacitance which allows it to achieve a typical bandwidth of up to 7.5 GHz. The device provides the high bandwidth necessary for HDMI and DisplayPort applications.

The TS3DV642 offers a power-down mode, in which all channels become Hi-Z and the device operates with minimal power.

Device Information⁽¹⁾

PART NUMBER	PACKAGE	BODY SIZE (NOM)
TS3DV642	WQFN (42)	9.00 mm x 3.50 mm

(1) For all available packages, see the orderable addendum at the end of the datasheet.

Simplified Schematic

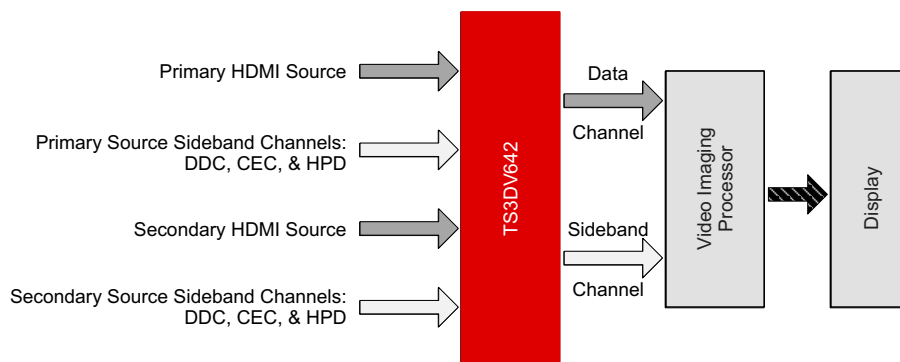

Table of Contents

1 Features	1	8.2 Functional Block Diagram	14
2 Applications	1	8.3 Feature Description.....	14
3 Description	1	8.4 Device Functional Modes.....	15
4 Revision History	2	9 Application and Implementation	17
5 Pin Configuration and Functions	4	9.1 Application Information.....	17
6 Specifications	6	9.2 Typical Application	17
6.1 Absolute Maximum Ratings	6	10 Power Supply Recommendations	22
6.2 ESD Ratings	6	11 Layout	23
6.3 Recommended Operating Conditions.....	6	11.1 Layout Guidelines	23
6.4 Thermal Information	6	11.2 Layout Example	24
6.5 Electrical Characteristics.....	7	12 Device and Documentation Support	25
6.6 Dynamic Characteristics	8	12.1 Receiving Notification of Documentation Updates	25
6.7 Switching Characteristics	8	12.2 Community Resources.....	25
6.8 Typical Characteristics.....	9	12.3 Trademarks	25
7 Parameter Measurement Information	12	12.4 Electrostatic Discharge Caution.....	25
8 Detailed Description	14	12.5 Glossary	25
8.1 Overview	14	13 Mechanical, Packaging, and Orderable Information	25

4 Revision History

NOTE: Page numbers for previous revisions may differ from page numbers in the current version.

Changes from Revision E (June 2017) to Revision F Page

- Changed [Figure 27](#), removed capacitors

21

Changes from Revision D (December 2015) to Revision E Page

- Changed *Application* From: DisplayPort 1.2a Signal Switching To: DisplayPort 1.4 Signal Switching.....
- Added Test Condition of 4.05 GHZ at –35 dB to Xtalk in the *Dynamic Characteristics* table.....
- Added Test Condition of 4.05 GHZ at –25 dB to OISO in the *Dynamic Characteristics* table.....

1

8

8

Changes from Revision C (November 2014) to Revision D Page

- Changed the storage temperature to the *Absolute Maximum Ratings* table

6

Changes from Revision B (August 2013) to Revision C Page

- Added Handling Rating table, Feature Description section, Device Functional Modes, Application and Implementation section, Power Supply Recommendations section, Layout section, Device and Documentation Support section, and Mechanical, Packaging, and Orderable Information section.
- Deleted row from ABS MAX table: Package thermal impedance
- Added the Handling Ratings table, deleted the T_{stg} row Absolute Maximum ratings table and added to Handling Ratings table.

1

6

6

Changes from Revision A (July 2013) to Revision B**Page**

• Changed <i>Application</i> From: HDMI 1.4/DVI 1.0 Signal Switching To: HDMI 1.4b with support for 4k2k up to 30 Hz	1
• Added <i>Application</i> : DVI 1.0 Signal Switching	1
• Changed <i>Application</i> From: DisplayPort 1.2 Signal Switching To: DisplayPort 1.2a Signal Switching.....	1
• Added Eye Pattern and Time Interval Error Histogram graphics, Figure 10 to Figure 13	10

5 Pin Configuration and Functions

RUA Package
42 Pin WQFN With Exposed Thermal Pad
Top View

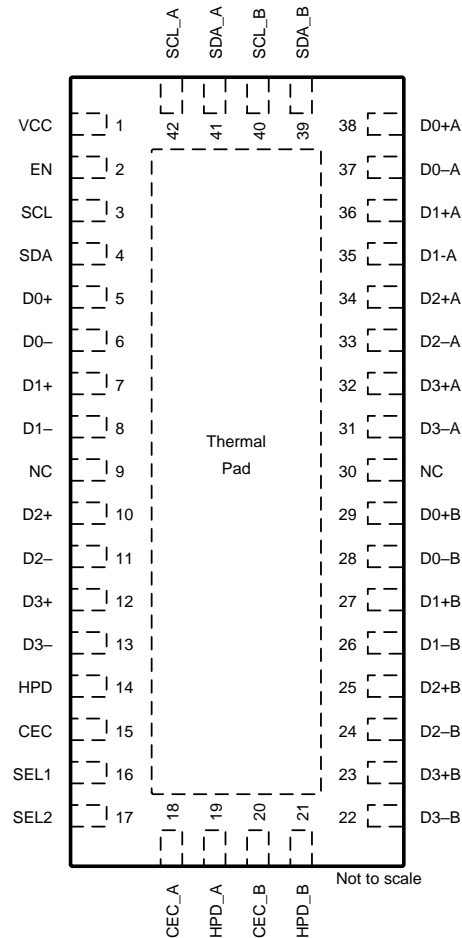

Pin Functions

PIN		TYPE	DESCRIPTION
NAME	NO.		
VCC	1	Power	Supply Voltage
SEL1	16	I	Select Input 1
SEL2	17	I	Select Input 2
EN	2	I	Output Enable
D0+A	38	I/O	Port A, Channel 0, +ve signal
D0-A	37	I/O	Port A, Channel 0, -ve signal
D1+A	36	I/O	Port A, Channel 1, +ve signal
D1-A	35	I/O	Port A, Channel 1, -ve signal
D2+A	34	I/O	Port A, Channel 2, +ve signal
D2-A	33	I/O	Port A, Channel 2, -ve signal
D3+A	32	I/O	Port A, Channel 3, +ve signal
D3-A	31	I/O	Port A, Channel 3, -ve signal
SCL_A	42	I/O	Port A, DDC Clock
SDA_A	41	I/O	Port A, DDC Data

Pin Functions (continued)

PIN		TYPE	DESCRIPTION
NAME	NO.		
HPD_A	19	I/O	Port A, Hot Plug Detects
CEC_A	18	I/O	Port A, Consumer Electronics Control
D0+B	29	I/O	Port B, Channel 0, +ve signal
D0-B	28	I/O	Port B, Channel 0, -ve signal
D1+B	27	I/O	Port B, Channel 1, +ve signal
D1-B	26	I/O	Port B, Channel 1, -ve signal
D2+B	25	I/O	Port B, Channel 2, +ve signal
D2-B	24	I/O	Port B, Channel 2, -ve signal
D3+B	23	I/O	Port B, Channel 3, +ve signal
D3-B	22	I/O	Port B, Channel 3, -ve signal
SCL_B	40	I/O	Port B, DDC Clock
SDA_B	39	I/O	Port B, DDC Data
HPD_B	21	I/O	Port B, Hot Plug Detects
CEC_B	20	I/O	Port B, Consumer Electronics Control
D0+	5	I/O	Common Port, Channel 0, +ve signal
D0-	6	I/O	Common Port, Channel 0, -ve signal
D1+	7	I/O	Common Port, Channel 1, +ve signal
D1-	8	I/O	Common Port, Channel 1, -ve signal
D2+	10	I/O	Common Port, Channel 2, +ve signal
D2-	11	I/O	Common Port, Channel 2, -ve signal
D3+	12	I/O	Common Port, Channel 3, +ve signal
D3-	13	I/O	Common Port, Channel 3, -ve signal
SCL	3	I/O	Common Port, DDC Clock
SDA	4	I/O	Common Port, DDC Data
HPD	14	I/O	Common Port, Hot Plug Detects
CEC	15	I/O	Common Port, Consumer Electronics Control
NC	9, 30	NC	No Connect
GND	PowerPad	GND	Ground

6 Specifications

6.1 Absolute Maximum Ratings

over operating free-air temperature range (unless otherwise noted)⁽¹⁾

		MIN	MAX	UNIT	
V _{CC}	Supply voltage range	-0.5	5.5	V	
V _{I/O}	Analog voltage range ⁽²⁾⁽³⁾⁽⁴⁾	All I/O	-0.5	5.5	V
V _{IN}	Digital input voltage range ⁽²⁾⁽³⁾	SEL1, SEL2, EN	-0.5	5.5	V
I _{I/O} K	Analog port diode current	V _{I/O} < 0	-50	mA	
I _{IK}	Digital input clamp current	V _{IN} < 0	-50	mA	
I _{I/O}	On-state switch current ⁽⁵⁾		-128	128	mA
T _{stg}	Storage temperature range		-65	150	°C

(1) Stresses beyond those listed under *Absolute Maximum Ratings* may cause permanent damage to the device. These are stress ratings only, which do not imply functional operation of the device at these or any other conditions beyond those indicated under *Recommended Operating Conditions*. Exposure to absolute-maximum-rated conditions for extended periods may affect device reliability.

(2) All voltages are with respect to ground, unless otherwise specified.

(3) The input and output voltage ratings may be exceeded if the input and output clamp-current ratings are observed.

(4) V_I and V_O are used to denote specific conditions for V_{I/O}.

(5) I_I and I_O are used to denote specific conditions for I_{I/O}.

6.2 ESD Ratings

		VALUE	UNIT
V _(ESD)	Electrostatic discharge	Human body model (HBM), per ANSI/ESDA/JEDEC JS-001, ⁽¹⁾	±2000
		Charged device model (CDM), per JEDEC specification JESD22-C101, ⁽²⁾	±1000
			V

(1) JEDEC document JEP155 states that 500-V HBM allows safe manufacturing with a standard ESD control process.

(2) JEDEC document JEP157 states that 250-V CDM allows safe manufacturing with a standard ESD control process.

6.3 Recommended Operating Conditions

over operating free-air temperature range (unless otherwise noted)⁽¹⁾

		MIN	MAX	UNIT
V _{CC}	Supply voltage	2.6	4.5	V
V _{I/O}	Input/Output voltage	0	5.5	V
T _A	Operating free-air temperature	-40	85	°C

(1) All unused control inputs of the device must be held at VDD or GND to ensure proper device operation. Refer to the *TI application report, Implications of Slow or Floating CMOS Inputs*, literature number [SCBA004](#).

6.4 Thermal Information

THERMAL METRIC ⁽¹⁾		TS3DV642	UNIT
		RUA	
		42 PINS	
R _{θJA}	Junction-to-ambient thermal resistance	31.5	°C/W
R _{θJC(top)}	Junction-to-case (top) thermal resistance	16.2	°C/W
R _{θJB}	Junction-to-board thermal resistance	5.5	°C/W
ψ _{JT}	Junction-to-top characterization parameter	0.2	°C/W
ψ _{JB}	Junction-to-board characterization parameter	5.4	°C/W
R _{θJC(bot)}	Junction-to-case (bottom) thermal resistance	2.0	°C/W

(1) For more information about traditional and new thermal metrics, see the *Semiconductor and IC Package Thermal Metrics* application report.

6.5 Electrical Characteristics

over operating free-air temperature range (unless otherwise noted)

PARAMETER		TEST CONDITIONS ⁽¹⁾	MIN	TYP ⁽²⁾	MAX	UNIT
PORT A						
R _{ON}	ON-state resistance	D0 to D3	V _{CC} = 3 V, 1.5 V ≤ V _{I/O} ≤ V _{CC} , I _{I/O} = -40 mA	6.5	9.5	Ω
		SCL, SDA, HPD, CEC		6	9.5	Ω
R _{ON(FLAT)} ⁽³⁾	ON-state resistance flatness	All I/O	V _{CC} = 3 V, V _{I/O} = 1.5 V and V _{CC} , I _{I/O} = -40 mA	1.5		Ω
ΔR _{ON} ⁽⁴⁾	On-state resistance match between high-speed channels	D0 to D3	V _{CC} = 3 V, 1.5 V ≤ V _{I/O} ≤ V _{CC} , I _{I/O} = -40 mA	0.4	1	Ω
I _{OFF}	Leakage under power off	All outputs	V _{CC} = 0 V, V _{I/O} = 0 to 3.6 V, V _{IN} = 0 V to 5.5 V		±10	μA
PORT B						
R _{ON}	ON-state resistance	D0 to D3	V _{CC} = 3 V, 1.5 V ≤ V _{I/O} ≤ V _{CC} , I _{I/O} = -40 mA	8.2	10.5	Ω
		SCL, SDA, HPD, CEC		6	9.5	Ω
R _{ON(FLAT)} ⁽³⁾	ON-state resistance flatness	All I/O	V _{CC} = 3 V, V _{I/O} = 1.5 V and V _{CC} , I _{I/O} = -40 mA	1.5		Ω
ΔR _{ON} ⁽⁴⁾	On-state resistance match between high-speed channels	D0 to D3	V _{CC} = 3 V, 1.5 V ≤ V _{I/O} ≤ V _{CC} , I _{I/O} = -40 mA	0.4	1	Ω
I _{OFF}	Leakage under power off	All outputs	V _{CC} = 0 V, V _{I/O} = 0 V to 3.6 V, V _{IN} = V to 5.5 V		±10	μA
DIGITAL INPUTS (SEL1, SEL2, EN)						
V _{IH}	High-level control input voltage	SEL1, SEL2, EN		1.4		V
V _{IL}	Low-level control input voltage	SEL1, SEL2, EN			0.5	V
I _{IH}	Digital input high leakage current	SEL1, SEL2, EN	V _{CC} = 3.6 V, V _{IN} = V _{DD}		±10	μA
I _{IL}	Digital input low leakage current	SEL1, SEL2, EN	V _{CC} = 3.6 V, V _{IN} = GND		±10	μA
SUPPLY						
I _{CC}	VCC supply current		V _{CC} = 3.6 V, I _{I/O} = 0, Normal Operation Mode, EN = H	50		μA
I _{CC, PD}	VCC supply current in power-down mode		V _{CC} = 3.6 V, I _{I/O} = 0, EN = L	6		μA

- (1) V_I, V_O, I_I, and I_O refer to I/O pins, V_{IN} refers to the control inputs.
(2) All typical values are at V_{CC} = 3.3 V (unless otherwise noted), T_A = 25°C.
(3) R_{ON(FLAT)} is the difference of R_{ON} in a given channel at specified voltages.
(4) ΔR_{ON} is the difference of R_{ON} from center port to any other ports.

6.6 Dynamic Characteristics

Over recommended operation free-air temperature range, $V_{CC} = 3.3V \pm 0.3V$ (unless otherwise noted)

PARAMETER		TEST CONDITIONS	MIN	TYP ⁽¹⁾	MAX	UNIT
C_{IN}	Digital input capacitance	$f = 1 \text{ MHz}, V_{IN} = 0 \text{ V}$		6		pF
C_{off}	Switch OFF capacitance	$f = 1 \text{ GHz}, V_{IO} = 0 \text{ V}$, Output is open, Switch is OFF		0.3		pF
C_{on}	Switch ON capacitance	$f = 1 \text{ GHz}, V_{IO} = 0 \text{ V}$, Output is open, Switch is ON		0.5		pF
Xtalk	Differential Crosstalk	$R_L = 50 \Omega$ at 1.7 GHz (See Figure 17)		-40		dB
		$R_L = 50 \Omega$ at 2.7 GHz (See Figure 17)		-40		
		$R_L = 50 \Omega$ at 4.05 GHz (See Figure 17)		-35		
OISO	Differential Off Isolation	$R_L = 50 \Omega$ at 1.7 GHz (See Figure 18)		-23		dB
		$R_L = 50 \Omega$ at 2.7 GHz (See Figure 18)		-28		
		$R_L = 50 \Omega$ at 4.05 GHz (See Figure 18)		-25		
IL	Insertion Loss	Port A at DC		-0.75		dB
		Port B at DC		-1		
BW	Differential Bandwidth (-3 dB)	Port A	$R_L = 50 \Omega$, All channels (See Figure 19)		6.9	GHz
		Port B	$R_L = 50 \Omega$, All channels (See Figure 19)		7.5	

(1) All Typical Values are at $V_{CC} = 3.3 \text{ V}$ (unless otherwise noted), $T_A = 25^\circ\text{C}$.

6.7 Switching Characteristics

over recommended operation free-air temperature range, $V_{CC} = 3.3 \text{ V} \pm 0.3 \text{ V}$ (unless otherwise noted)

PARAMETER		TEST CONDITIONS	MIN	TYP ⁽¹⁾	MAX	UNIT
t_{ON} ⁽²⁾	Switch turn-on time	All I/O			100	μs
t_{SWITCH} ⁽³⁾	Switching time between channels	All I/O		20		μs
t_{pd}	Propagation Delay	Port A	D0 to D3		30	ps
			SCL, SDA, HPD, CEC		30	
		Port B	D0 to D3		40	
			SCL, SDA, HPD, CEC	See Figure 16		
t_{SKEW}	Inter-pair Skew	Port A	D0 to D3	Between +ve and -ve signals of each Channel		2
		Port B				2
	Intra-pair Skew	Port A		Between Channel 0, 1, 2, or 3		2
		Port B				6

(1) All typical values are at $V_{CC} = 3.3 \text{ V}$ (unless otherwise noted), $T_A = 25^\circ\text{C}$.

(2) t_{ON} is the time it takes the output to recover after enabling switches

(3) t_{SWITCH} is the time it takes for the output to recover after the state is changed

6.8 Typical Characteristics

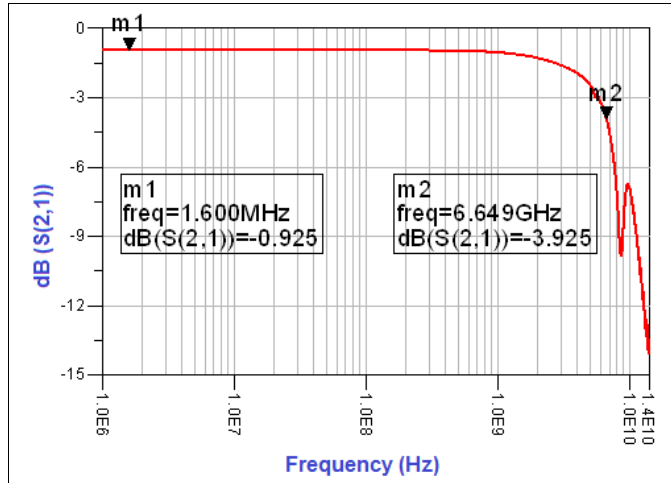

Figure 1. Differential S21 vs Frequency for Port A

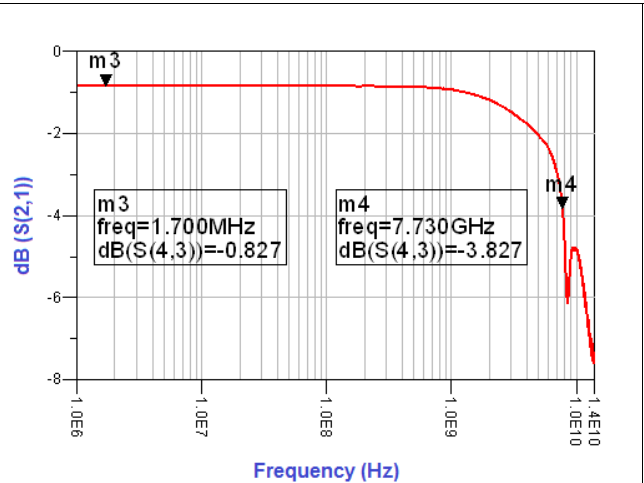

Figure 2. Differential S21 vs Frequency for Port B

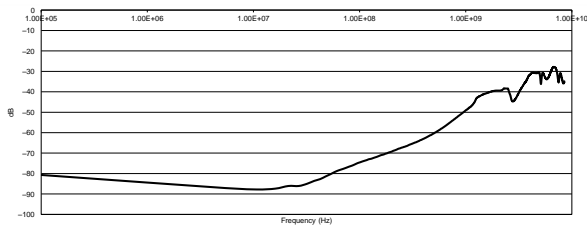

Figure 3. XTALK Port A

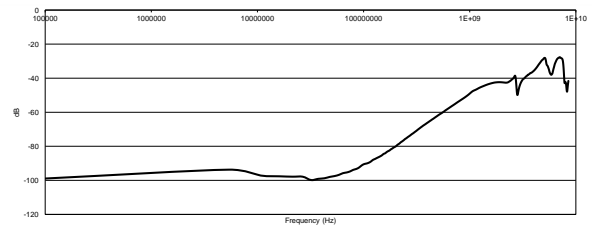

Figure 4. XTALK Port B

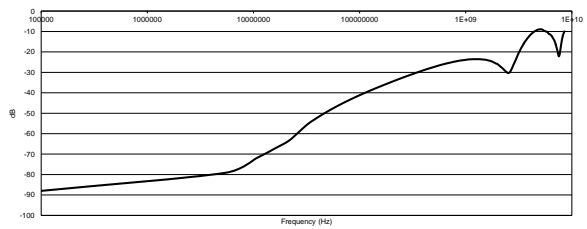

Figure 5. Off-State Isolation (OISO) for Port A

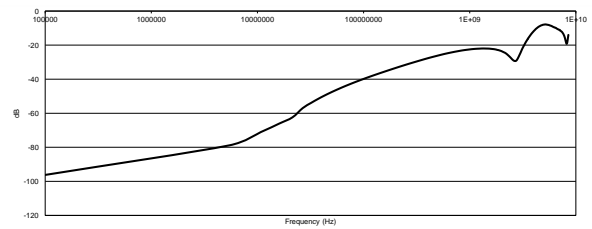

Figure 6. Off-State Isolation (OISO) for Port B

Typical Characteristics (continued)

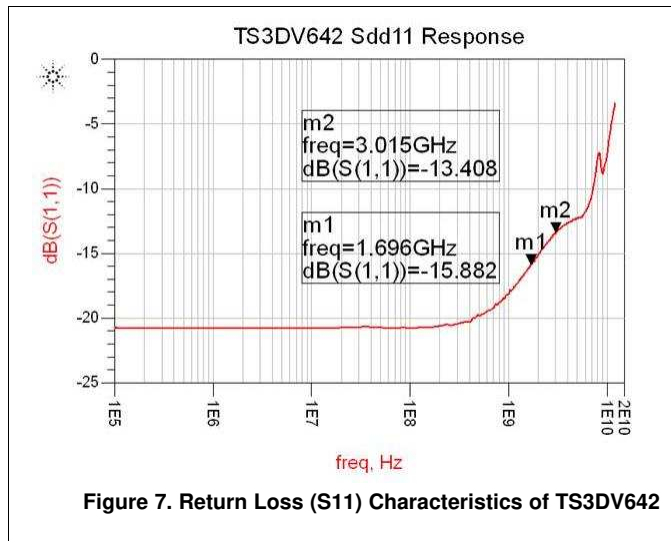

Figure 7. Return Loss (S11) Characteristics of TS3DV642

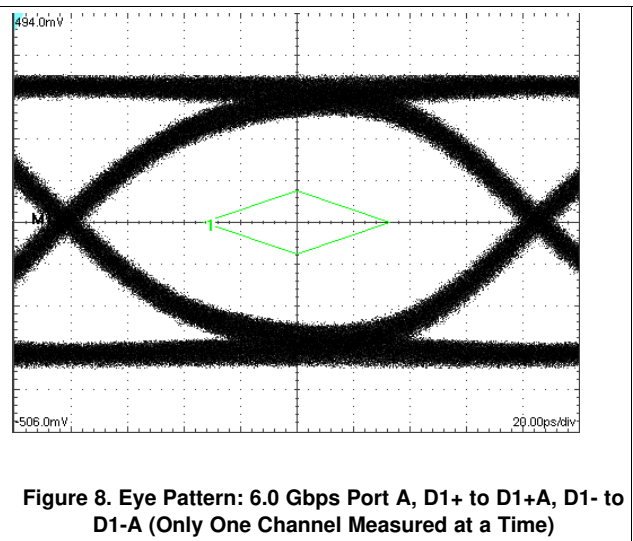

Figure 8. Eye Pattern: 6.0 Gbps Port A, D1+ to D1+A, D1- to D1-A (Only One Channel Measured at a Time)

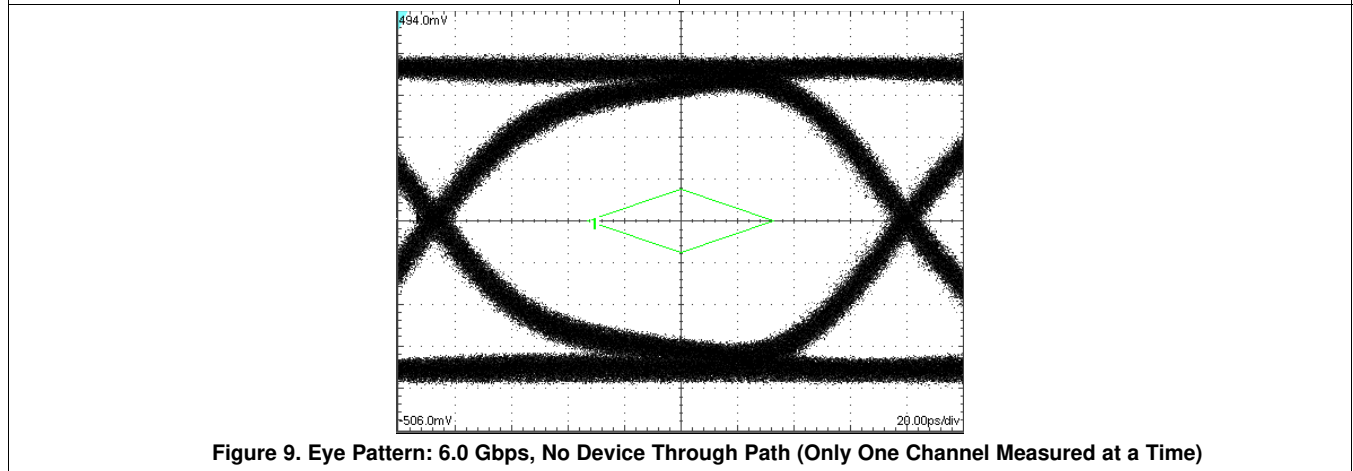

Figure 9. Eye Pattern: 6.0 Gbps, No Device Through Path (Only One Channel Measured at a Time)

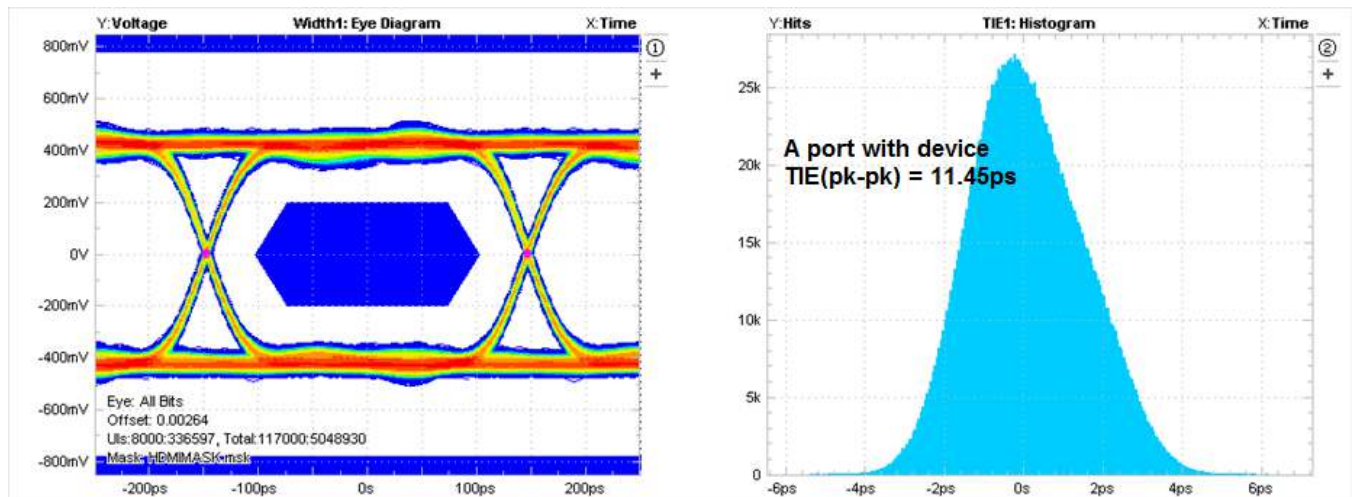

Figure 10. Eye Pattern and Time Interval Error Histogram: 3.4 Gbps Port A, With Device

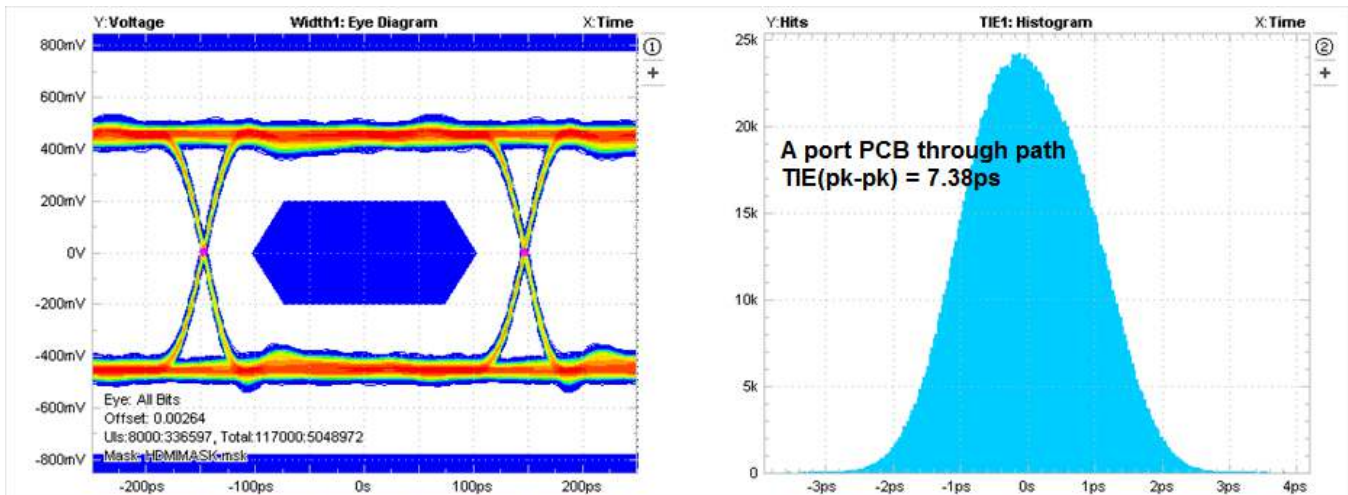

Figure 11. Eye Pattern and Time Interval Error Histogram: 3.4 Gbps, No Device Through Path

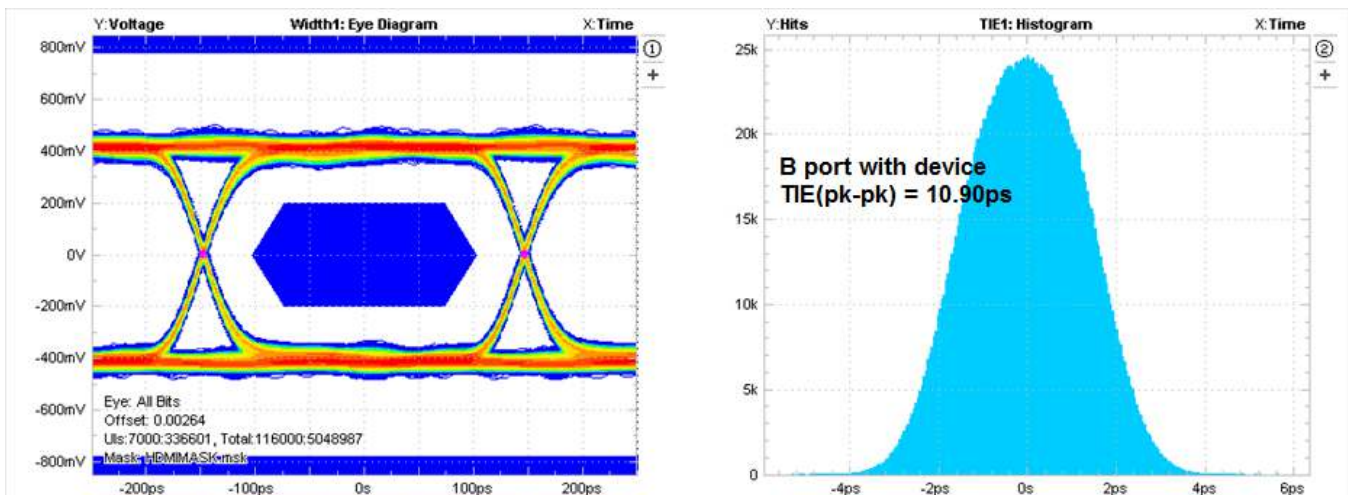

Figure 12. Eye Pattern and Time Interval Error Histogram: 3.4 Gbps Port B, With Device

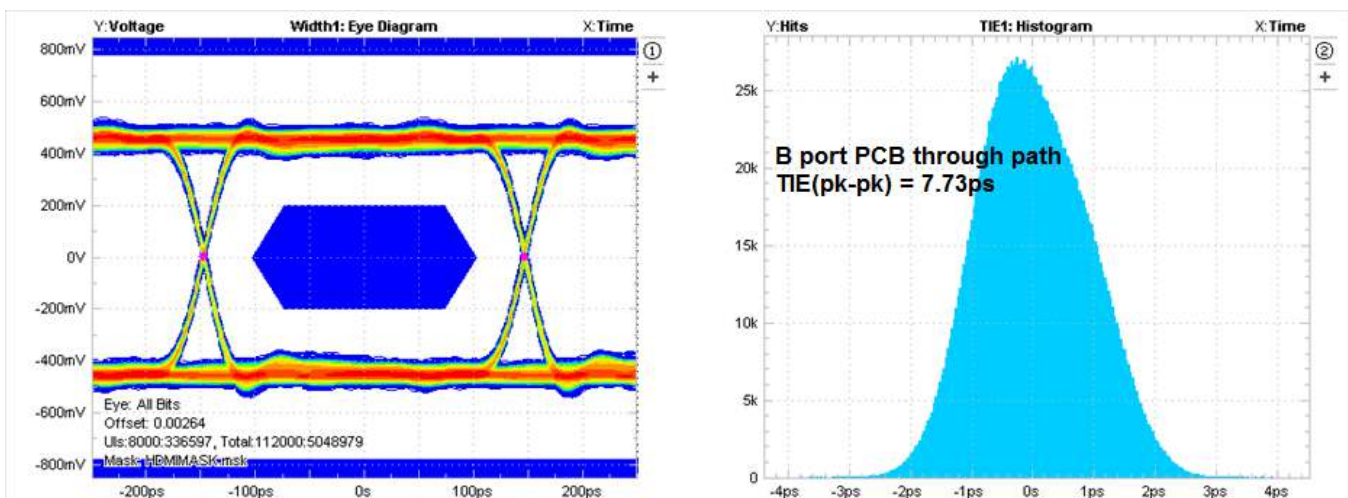
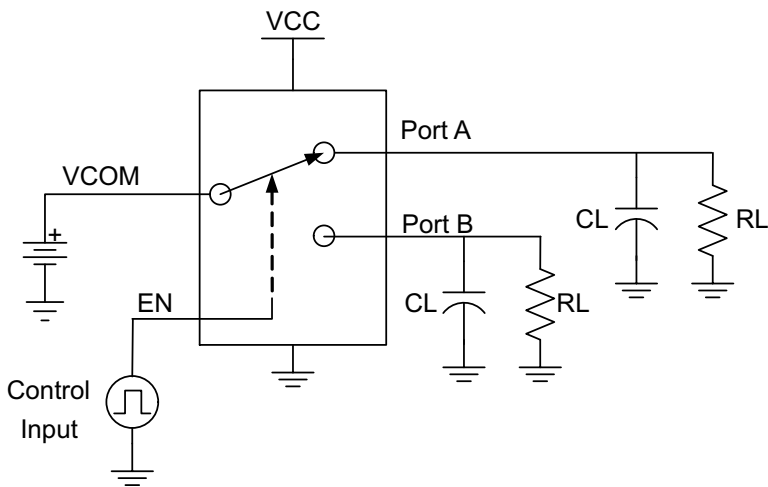

Figure 13. Eye Pattern and Time Interval Error Histogram: 3.4 Gbps Port B, No Device

7 Parameter Measurement Information



RL	CL	VCOM
50 Ω	4 pF	VCC

*CL includes probe, cable, and board capacitance

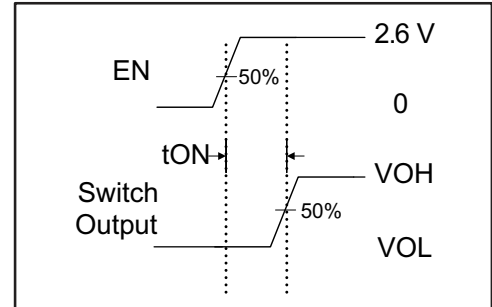
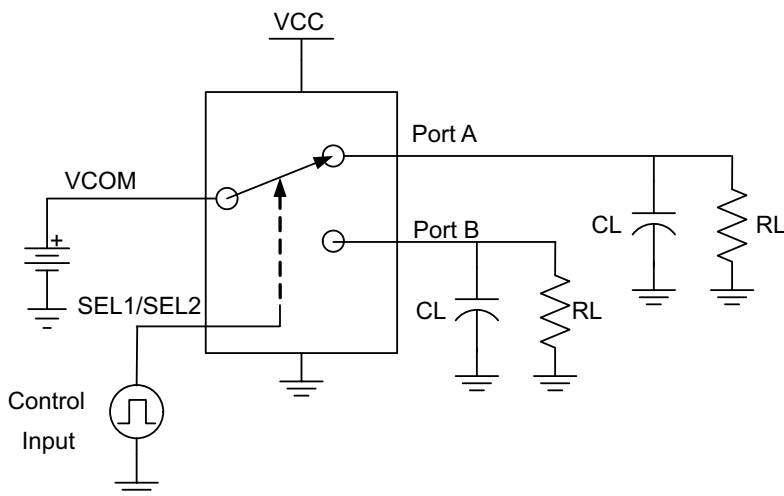

Figure 14. Switch Turn-On Time (t_{ON})



RL	CL	VCOM
50 Ω	4 pF	VCC

*CL includes probe, cable, and board capacitance

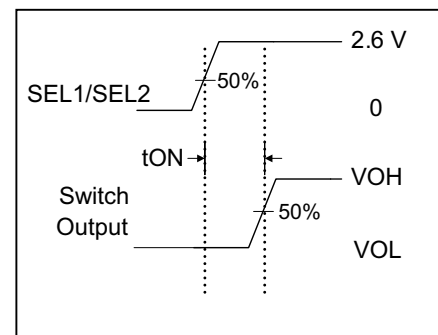
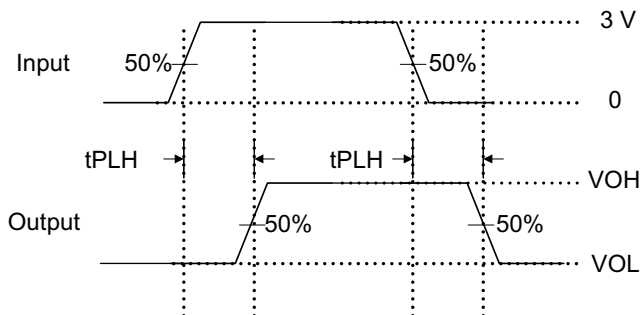

Figure 15. Switching Time Between Channels (t_{SWITCH})



$$t_{pd} = (t_{PLH} + t_{PLH}) / 2$$

Figure 16. Propagation Delay (t_{pd})

Parameter Measurement Information (continued)

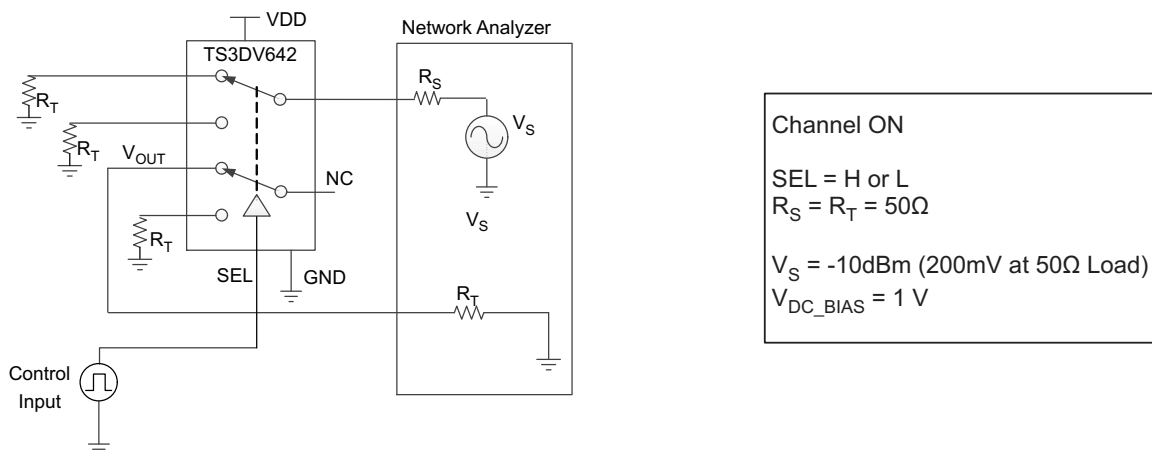

Figure 17. Crosstalk (Xtalk)

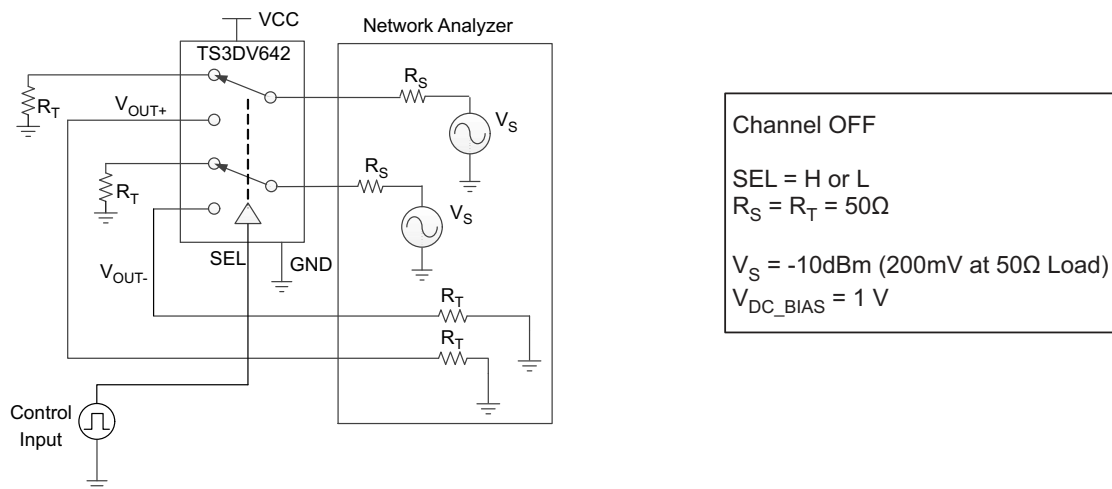

Figure 18. Differential Off-Isolation (OISO)

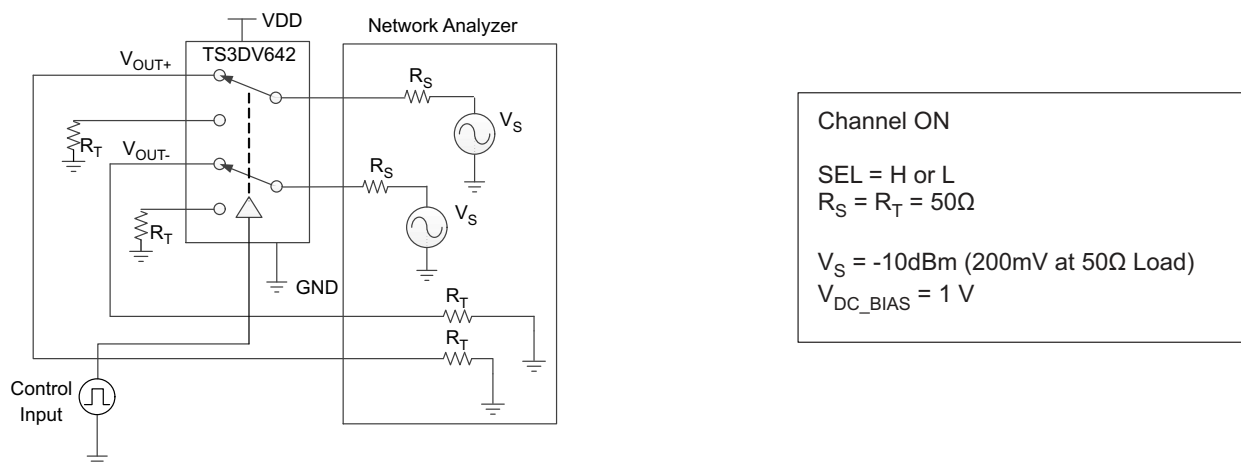

Figure 19. Differential Bandwidth (BW)

8 Detailed Description

8.1 Overview

TS3DV642 is a 12-channel 1:2 or 2:1 bidirectional multiplexer/demultiplexer. The TS3DV642 operates from a 2.6 to 4.5 V supply, making it suitable for battery-powered applications. It offers low and flat on-state resistance as well as low I/O capacitance which allows it to achieve a typical bandwidth of up to 7.5 GHz. The device provides the high bandwidth necessary for HDMI and DisplayPort applications.

8.2 Functional Block Diagram

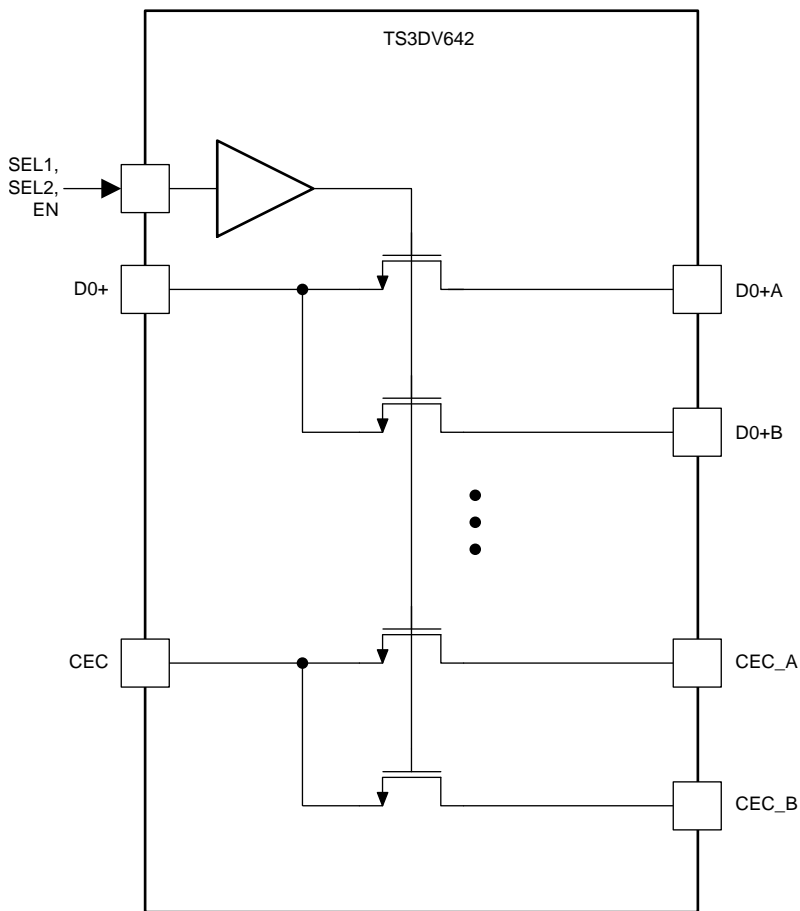

8.3 Feature Description

The TS3DV642 is based on proprietary TI technology which uses FET switches driven by a high-voltage generated from an integrated charge-pump to achieve a low on-state resistance. TS3DV642 has 12-channel bidirectional switches with a high bandwidth (~ 7.5 GHz). TS3DV642 uses an extremely low power technology and uses only 50 μA I_{CC} in active mode. The device has integrated ESD that can support up to 2-kV Human-Body Model (HBM) and 1-kV Charge Device Model (CDM). TS3DV642 is offered in a 42-pin QFN package (9 mm x 3.5 mm) with 0.5 mm pitch. The device can support analog I/O signal in 0 to 5 V range. TS3DV642 also has a special feature that prevents the device from back-powering when the V_{CC} supply is not available and an analog signal is applied on the I/O pin. In this situation this special feature prevents leakage current in the device. The TS3DV642 is not designed for passing signals with negative swings; the high-speed signals need to be properly DC biased (usually ~1 V) before being passed to the TS3DV642. The differential S21 characteristics as a function of frequency for Port A and Port B are shown in [Figure 1](#) and [Figure 2](#), respectively. The figures show a differential bandwidth of 6.7 GHz and 7.7 GHz for Port A and Port B, respectively. The cross-talk (XTALK) characteristics as a function of frequency are shown in [Figure 3](#) and [Figure 4](#), respectively. The off-state isolation (OISO) characteristics for Port A and Port B are shown in [Figure 5](#) and [Figure 6](#), respectively. The return loss

Feature Description (continued)

characteristics (S11) are shown in Figure 7. The eye pattern and Time Interval Error (TIE) histogram at 3.4 Gbps (for HDMI 1.4 applications) with TS3DV642 in path for Port A is shown in Figure 10. The eye pattern and Time Interval Error (TIE) histogram at 3.4 Gbps through path (no TS3DV642) for Port A is shown in Figure 11. The eye pattern and Time Interval Error (TIE) histogram at 3.4 Gbps (for HDMI 1.4 applications) with TS3DV642 in path for Port B is shown in Figure 12. The eye pattern and Time Interval Error (TIE) histogram at 3.4 Gbps through path (no TS3DV642) for Port A is shown in Figure 13. The eye pattern at 6.0 Gbps (for HDMI 2.0 applications) with TS3DV642 in path for Port A is shown in Figure 8. The eye pattern at 6.0 Gbps (for HDMI 2.0 applications) through path (no TS3DV642) for Port A is shown in Figure 9. Note that the eye patterns are measured with only one channel on at a time.

8.4 Device Functional Modes

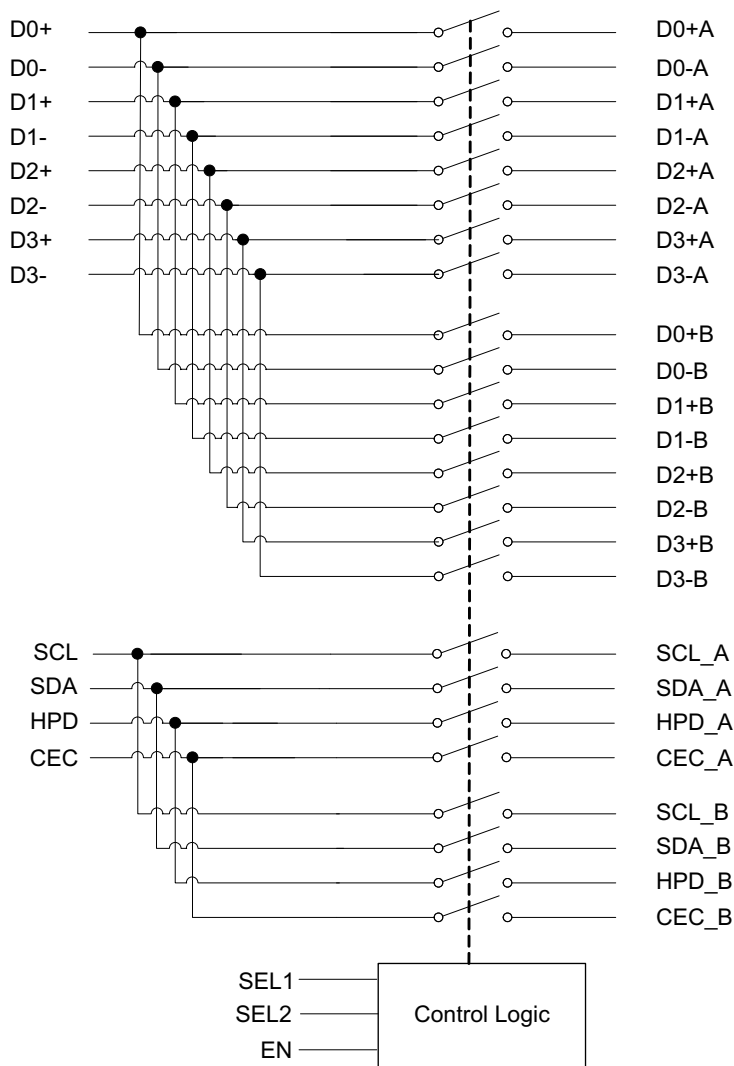

Figure 20. Logic Diagram

Device Functional Modes (continued)

[Table 1](#) lists the device functions for the TS3DV642 device.

Table 1. Functional Table

EN	SEL1	SEL2	FUNCTION
L	X	X	Switch disabled. All channels are Hi-Z.
H	L	L	Channel D0+/D0– to D0+A/D0–A is ON. All the other channels (D1+/D1–, D2+/D2–, D3+/D3–, SCL, SDA, HPD, CEC) are Hi-Z.
H	L	H	Channel D0+/D0– to D0+B/D0–B is ON. All the other channels (D1+/D1–, D2+/D2–, D3+/D3–, SCL, SDA, HPD, CEC) are Hi-Z.
H	H	L	All A channels are enabled. All B channels are Hi-Z.
H	H	H	All B channels are enabled. All A channels are Hi-Z.

9 Application and Implementation

NOTE

Information in the following applications sections is not part of the TI component specification, and TI does not warrant its accuracy or completeness. TI's customers are responsible for determining suitability of components for their purposes. Customers should validate and test their design implementation to confirm system functionality.

9.1 Application Information

TS3DV642 can be used for two typical DisplayPort applications. Figure 21 describes a DisplayPort (DP) application where TS3DV642 is used to switch between two different graphic & memory controllers on a single DP connector. Figure 24 shows a docking application where TS3DV642 is used to switch signals from a single graphic and memory controller to a display port and docking station connector. Note that the TS3DV642 is not designed for passing signals with negative swings; the high-speed signals need to be properly DC biased (usually ~1 V from the graphic controller side) before being passed to the TS3DV642.

9.2 Typical Application

9.2.1 Display Port (DP) Application

Display port (DP) application with TS3DV642 used to switch between two different graphic & memory controllers on a single DP connector

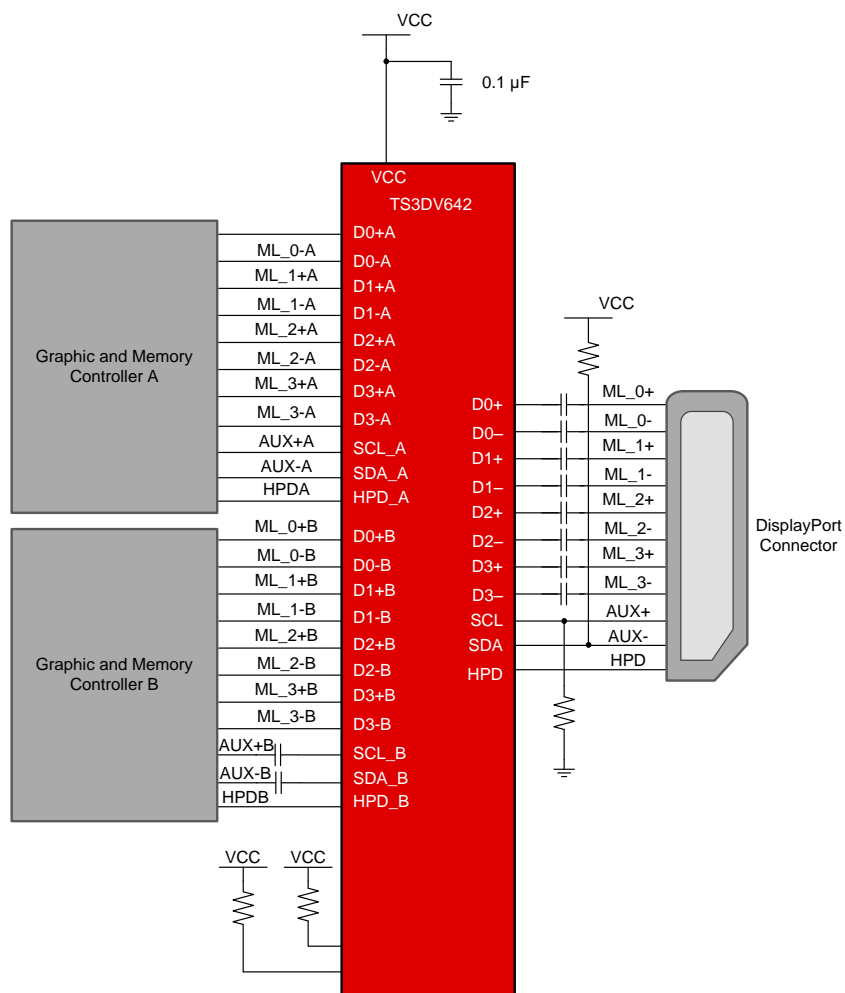

Figure 21. Display Port Schematic

Typical Application (continued)

9.2.1.1 Design Requirements

Table 2. Design parameters for Display Port application

Design parameter	Example value
V _{CC}	2.6 V to 4.5 V
VCC decoupling capacitor	0.1 μF
MainLink (ML) and AUX coupling capacitor	75 nF to 200 nF
AUX Pull-up / Pull-down resistors	10 kΩ to 100 kΩ
Pull-up / Pull-down resistors for SEL1 / SEL2 pins	10 kΩ

9.2.1.2 Detailed Design Procedure

The TS3DV642 is designed to operate with 2.6 V – 4.5 V power supply. The wide power supply range allows flexibility for battery powered applications. If a higher power supply is used in the system, a voltage regulator can be used to bring down the voltage to 2.6 V – 4.5 V range. Decoupling capacitors may be used to reduce noise and improve power supply integrity. AC coupling capacitors in 75 nF – 200 nF range must be placed on the MainLink (ML) and AUX lanes. In this particular application the AC coupling capacitors are shown on the connector side. The AC coupling capacitors may also be placed on the signal path on controller side. The AUX+ line must be pulled-down weakly through a resistor to ground and the AUX– line must be pulled-up weakly through a resistor to VCC.

9.2.1.3 Application Curves

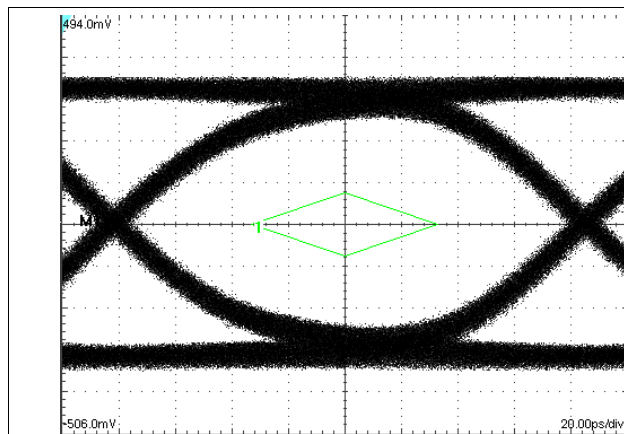

Figure 22. Eye Pattern: 6.0 Gbps Port A, D1+ to D1+A, D1- to D1-A (Only One Channel Measured at a Time)

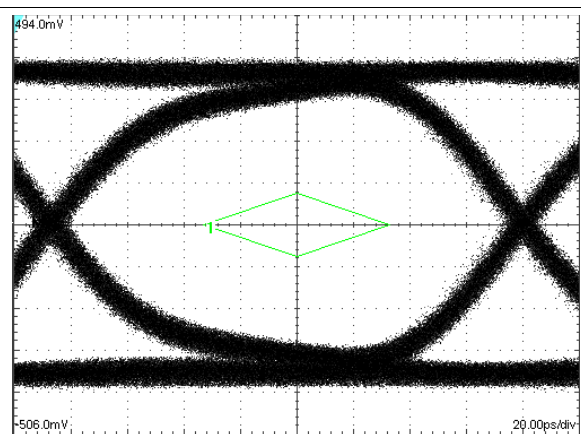

Figure 23. Eye Pattern: 6.0 Gbps, No Device Through Path (Only One Channel Measured at a Time)

9.2.2 Docking Application

Docking Application with TS3DV642 used to switch signals from a single graphic and memory controller to a display port and docking station connector.

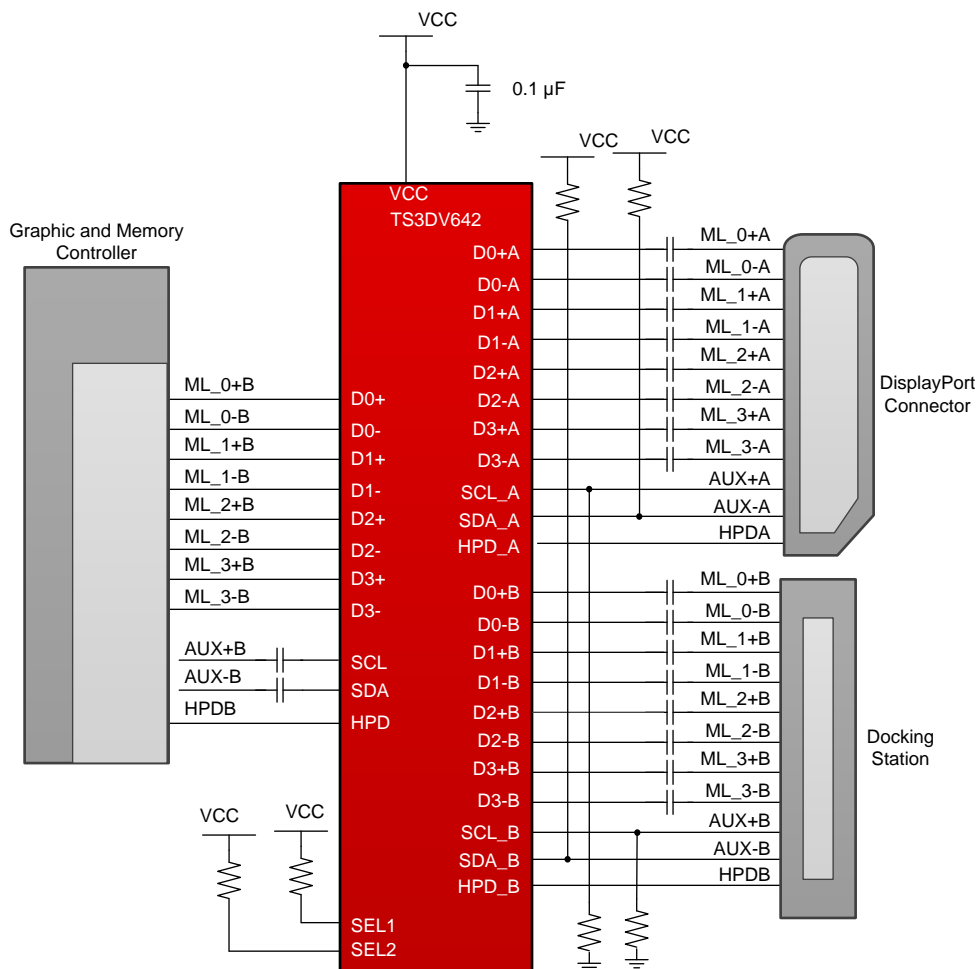

Figure 24. Docking Application Schematic

9.2.2.1 Design Requirements

Table 3. Design parameters for docking application

Design parameter	Example value
V _{CC}	2.6 V to 4.5 V
VCC decoupling capacitor	0.1 µF
MainLink (ML) and AUX coupling capacitor	75 nF to 200 nF
AUX Pull-up / Pull-down resistors	10 kΩ to 100 kΩ
Pull-up / Pull-down resistors for SEL1 / SEL2 pins	10 kΩ

9.2.2.2 Detailed Design Procedure

The TS3DV642 is designed to operate with 2.6 V – 4.5 V power supply. The wide power supply range allows flexibility for battery powered applications. If a higher power supply is used in the system, a voltage regulator can be used to bring down the voltage to 2.6 V – 4.5 V range. Decoupling capacitors may be used to reduce noise and improve power supply integrity. AC coupling capacitors in 75 nF – 200 nF range must be placed on the MainLink (ML) and AUX lanes. In this particular application the AC coupling capacitors are shown on the connector side. The AC coupling capacitors may also be placed on the signal path on controller side. The AUX+ line must be pulled-down weakly through a resistor to ground and the AUX– line must be pulled-up weakly through a resistor to VCC.

9.2.2.3 Application Curves

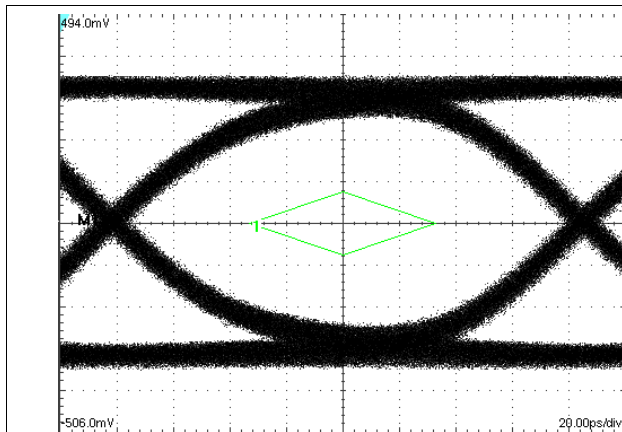

Figure 25. Eye Pattern: 6.0 Gbps Port A, D1+ to D1+A, D1- to D1-A (Only One Channel Measured at a Time)

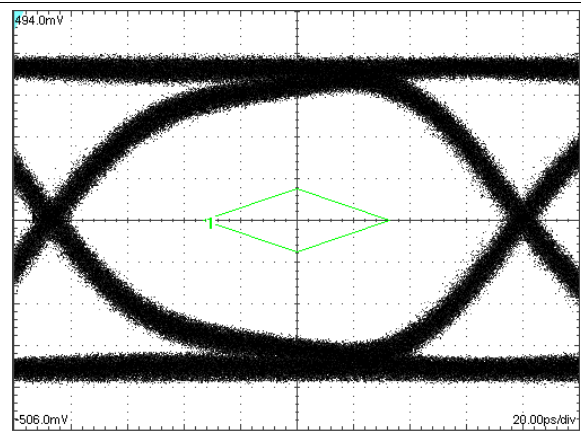

Figure 26. Eye Pattern: 6.0 Gbps, No Device Through Path (Only One Channel Measured at a Time)

9.2.3 HDMI Application

HDMI Application with TS3DV642 used to switch signals from a single graphic and memory controller to a two HDMI connectors.

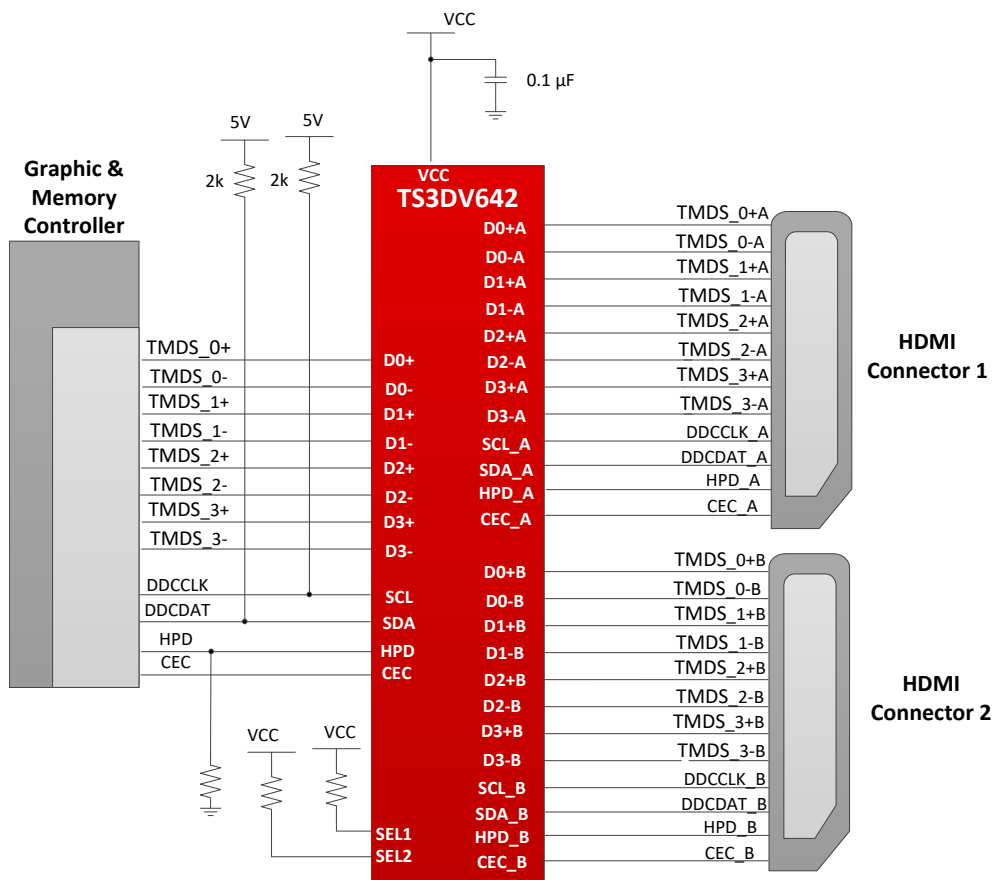

Figure 27. HDMI Application Schematic

9.2.3.1 Design Requirements

Table 4. Design Parameters for HDMI Application

Design parameter	Example value
V _{CC}	2.6 V to 4.5 V
VCC decoupling capacitor	0.1 µF
DDC Pull-up resistors	2 kΩ to 5 V
Pull-up / Pull-down resistors for SEL1 / SEL2 pins	10 kΩ
HPD Pull-down resistor	100 kΩ

9.2.3.2 Detailed Design Procedure

The TS3DV642 is designed to operate with 2.6 V – 4.5 V power supply. The wide power supply range allows flexibility for battery powered applications. If a higher power supply is used in the system, a voltage regulator can be used to bring down the voltage to 2.6 V – 4.5 V range. Decoupling capacitors may be used to reduce noise and improve power supply integrity. Pull-up resistors to 5 V must be placed on the source side DDC clock and data lines according to the HDMI standard. A weak pull-down resistor must be placed on the source side HPD line.

9.2.3.3 Application Curves

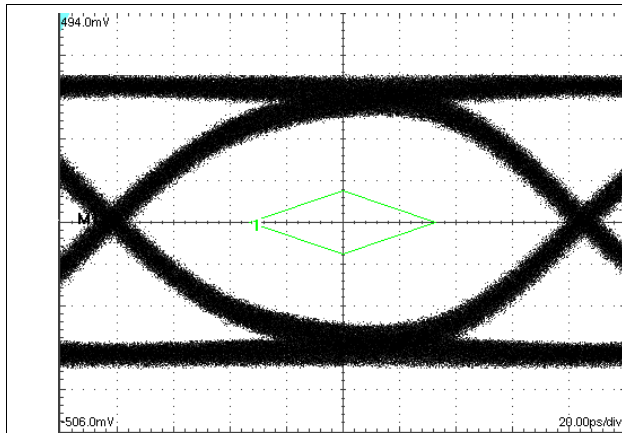

Figure 28. Eye Pattern: 6 Gbps Port A, D1+ to D1+A, D1- to D1-A (Only One Channel Measured at a Time)

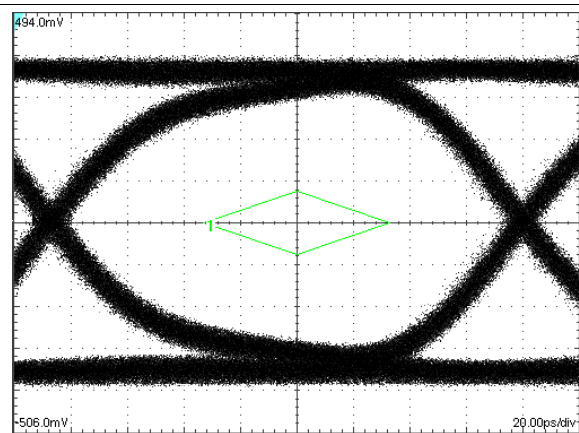

Figure 29. Eye Pattern: 6 Gbps, No Device Through Path (Only One Channel Measured at a Time)

10 Power Supply Recommendations

V_{CC} should be in the range of 2.6 V to 4.5 V. Voltage levels above those listed in the Absolute Ratings table should not be used. Decoupling capacitors may be used to reduce noise and improve power supply integrity. There are no power sequence requirements for the TS3DV642.

11 Layout

11.1 Layout Guidelines

To ensure reliability of the device, the following commonly used printed-circuit board layout guidelines are recommended:

- Decoupling capacitors should be used between power supply pin and ground pin to ensure low impedance to reduce noise. To achieve a low impedance over a wide frequency range use capacitors with a high self-resonance frequency.
- ESD and EMI protection devices (if used) should be placed as close as possible to the connector.
- Short trace lengths should be used to avoid excessive loading.
- To minimize the effects of crosstalk on adjacent traces, keep the traces at least two times the trace width apart.
- Separate high-speed signals from low-speed signals and digital from analog signals.
- Avoid right-angle bends in a trace and try to route them at least with two 45° corners.
- The high-speed differential signal traces should be routed parallel to each other as much as possible. The traces are recommended to be symmetrical.
- A solid ground plane should be placed next to the high-speed signal layer. This also provides an excellent low-inductance path for the return current flow.

TS3DV642

SCDS343F –MAY 2013–REVISED AUGUST 2018

www.ti.com

11.2 Layout Example

TS3DV642 application with a single controller interfacing with two HDMI connectors.

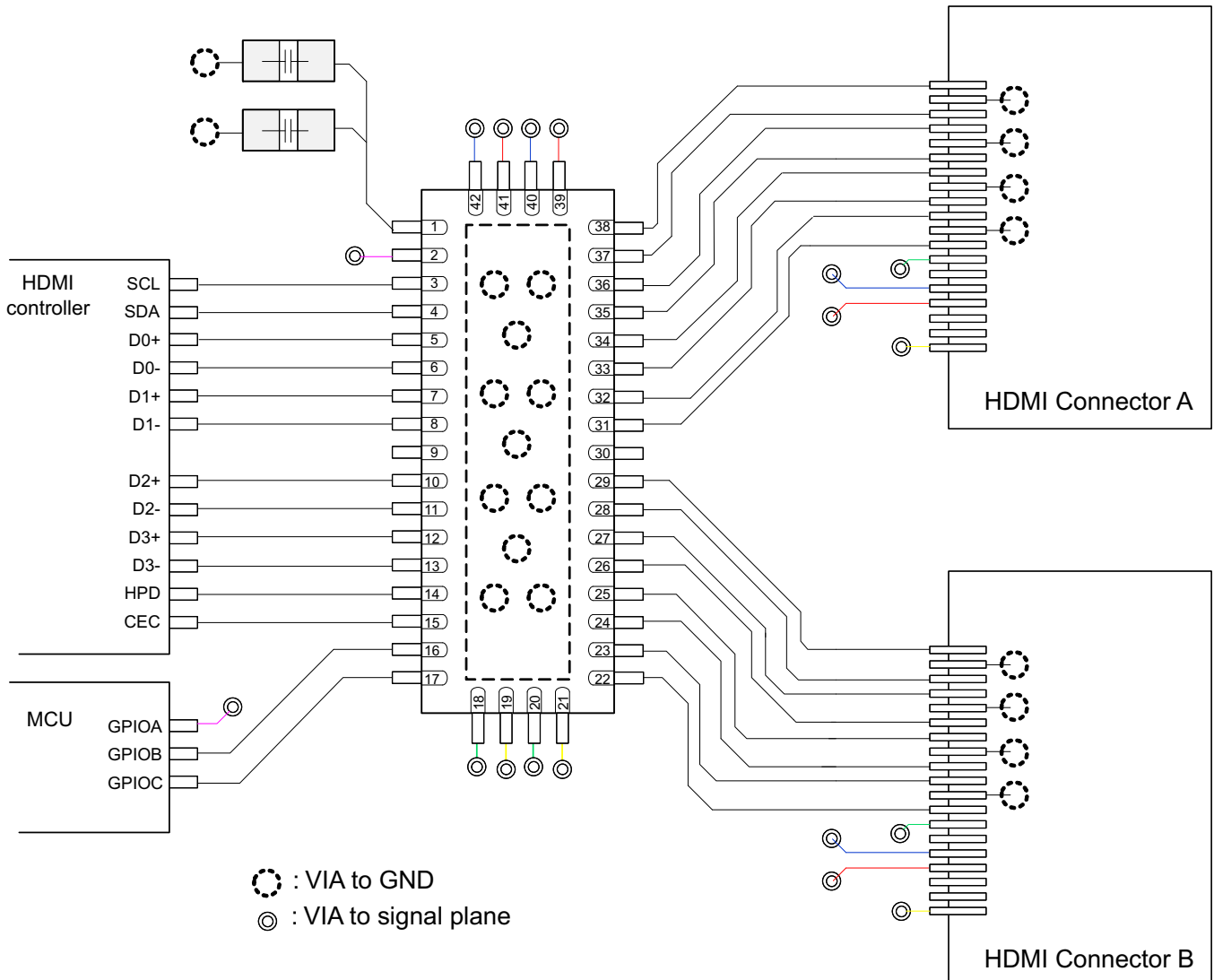

Figure 30. Layout Example

12 Device and Documentation Support

12.1 Receiving Notification of Documentation Updates

To receive notification of documentation updates, navigate to the device product folder on ti.com. In the upper right corner, click on *Alert me* to register and receive a weekly digest of any product information that has changed. For change details, review the revision history included in any revised document.

12.2 Community Resources

The following links connect to TI community resources. Linked contents are provided "AS IS" by the respective contributors. They do not constitute TI specifications and do not necessarily reflect TI's views; see TI's [Terms of Use](#).

TI E2E™ Online Community *TI's Engineer-to-Engineer (E2E) Community*. Created to foster collaboration among engineers. At e2e.ti.com, you can ask questions, share knowledge, explore ideas and help solve problems with fellow engineers.

Design Support *TI's Design Support* Quickly find helpful E2E forums along with design support tools and contact information for technical support.

12.3 Trademarks

E2E is a trademark of Texas Instruments.
All other trademarks are the property of their respective owners.

12.4 Electrostatic Discharge Caution



These devices have limited built-in ESD protection. The leads should be shorted together or the device placed in conductive foam during storage or handling to prevent electrostatic damage to the MOS gates.

12.5 Glossary

[SLYZ022](#) — *TI Glossary*.

This glossary lists and explains terms, acronyms, and definitions.

13 Mechanical, Packaging, and Orderable Information

The following pages include mechanical, packaging, and orderable information. This information is the most current data available for the designated devices. This data is subject to change without notice and revision of this document. For browser-based versions of this data sheet, refer to the left-hand navigation.

PACKAGING INFORMATION

Orderable Device	Status (1)	Package Type	Package Drawing	Pins	Package Qty	Eco Plan (2)	Lead finish/ Ball material (6)	MSL Peak Temp (3)	Op Temp (°C)	Device Marking (4/5)	Samples
TS3DV642A0RUAR	ACTIVE	WQFN	RUA	42	3000	RoHS & Green	NIPDAU	Level-3-260C-168 HR	-40 to 85	SD642A0	Samples

(1) The marketing status values are defined as follows:

ACTIVE: Product device recommended for new designs.

LIFEBUY: TI has announced that the device will be discontinued, and a lifetime-buy period is in effect.

NRND: Not recommended for new designs. Device is in production to support existing customers, but TI does not recommend using this part in a new design.

PREVIEW: Device has been announced but is not in production. Samples may or may not be available.

OBSOLETE: TI has discontinued the production of the device.

(2) **RoHS:** TI defines "RoHS" to mean semiconductor products that are compliant with the current EU RoHS requirements for all 10 RoHS substances, including the requirement that RoHS substance do not exceed 0.1% by weight in homogeneous materials. Where designed to be soldered at high temperatures, "RoHS" products are suitable for use in specified lead-free processes. TI may reference these types of products as "Pb-Free".

RoHS Exempt: TI defines "RoHS Exempt" to mean products that contain lead but are compliant with EU RoHS pursuant to a specific EU RoHS exemption.

Green: TI defines "Green" to mean the content of Chlorine (Cl) and Bromine (Br) based flame retardants meet JS709B low halogen requirements of <=1000ppm threshold. Antimony trioxide based flame retardants must also meet the <=1000ppm threshold requirement.

(3) MSL, Peak Temp. - The Moisture Sensitivity Level rating according to the JEDEC industry standard classifications, and peak solder temperature.

(4) There may be additional marking, which relates to the logo, the lot trace code information, or the environmental category on the device.

(5) Multiple Device Markings will be inside parentheses. Only one Device Marking contained in parentheses and separated by a "-" will appear on a device. If a line is indented then it is a continuation of the previous line and the two combined represent the entire Device Marking for that device.

(6) Lead finish/Ball material - Orderable Devices may have multiple material finish options. Finish options are separated by a vertical ruled line. Lead finish/Ball material values may wrap to two lines if the finish value exceeds the maximum column width.

Important Information and Disclaimer:The information provided on this page represents TI's knowledge and belief as of the date that it is provided. TI bases its knowledge and belief on information provided by third parties, and makes no representation or warranty as to the accuracy of such information. Efforts are underway to better integrate information from third parties. TI has taken and continues to take reasonable steps to provide representative and accurate information but may not have conducted destructive testing or chemical analysis on incoming materials and chemicals. TI and TI suppliers consider certain information to be proprietary, and thus CAS numbers and other limited information may not be available for release.

In no event shall TI's liability arising out of such information exceed the total purchase price of the TI part(s) at issue in this document sold by TI to Customer on an annual basis.

OTHER QUALIFIED VERSIONS OF TS3DV642 :

- Automotive : [TS3DV642-Q1](#)

NOTE: Qualified Version Definitions:

- Automotive - Q100 devices qualified for high-reliability automotive applications targeting zero defects

TAPE AND REEL INFORMATION



QUADRANT ASSIGNMENTS FOR PIN 1 ORIENTATION IN TAPE



*All dimensions are nominal

Device	Package Type	Package Drawing	Pins	SPQ	Reel Diameter (mm)	Reel Width W1 (mm)	A0 (mm)	B0 (mm)	K0 (mm)	P1 (mm)	W (mm)	Pin1 Quadrant
TS3DV642A0RUAR	WQFN	RUA	42	3000	330.0	16.4	3.8	9.3	1.0	8.0	16.0	Q1

TAPE AND REEL BOX DIMENSIONS



*All dimensions are nominal

Device	Package Type	Package Drawing	Pins	SPQ	Length (mm)	Width (mm)	Height (mm)
TS3DV642A0RUAR	WQFN	RUA	42	3000	367.0	367.0	38.0

GENERIC PACKAGE VIEW

RUA 42

WQFN - 0.8 mm max height

9 x 3.5, 0.5 mm pitch

PLASTIC QUAD FLATPACK - NO LEAD

This image is a representation of the package family, actual package may vary.
Refer to the product data sheet for package details.

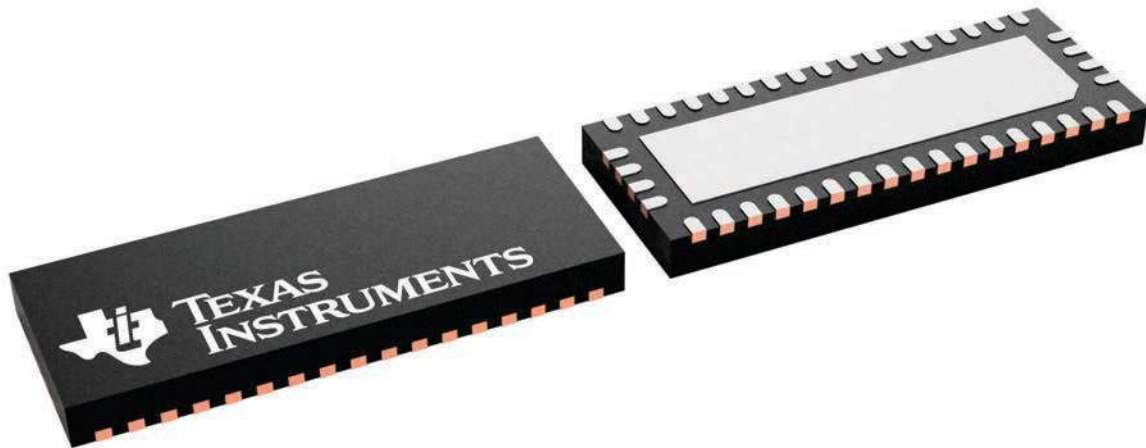

4226504/A

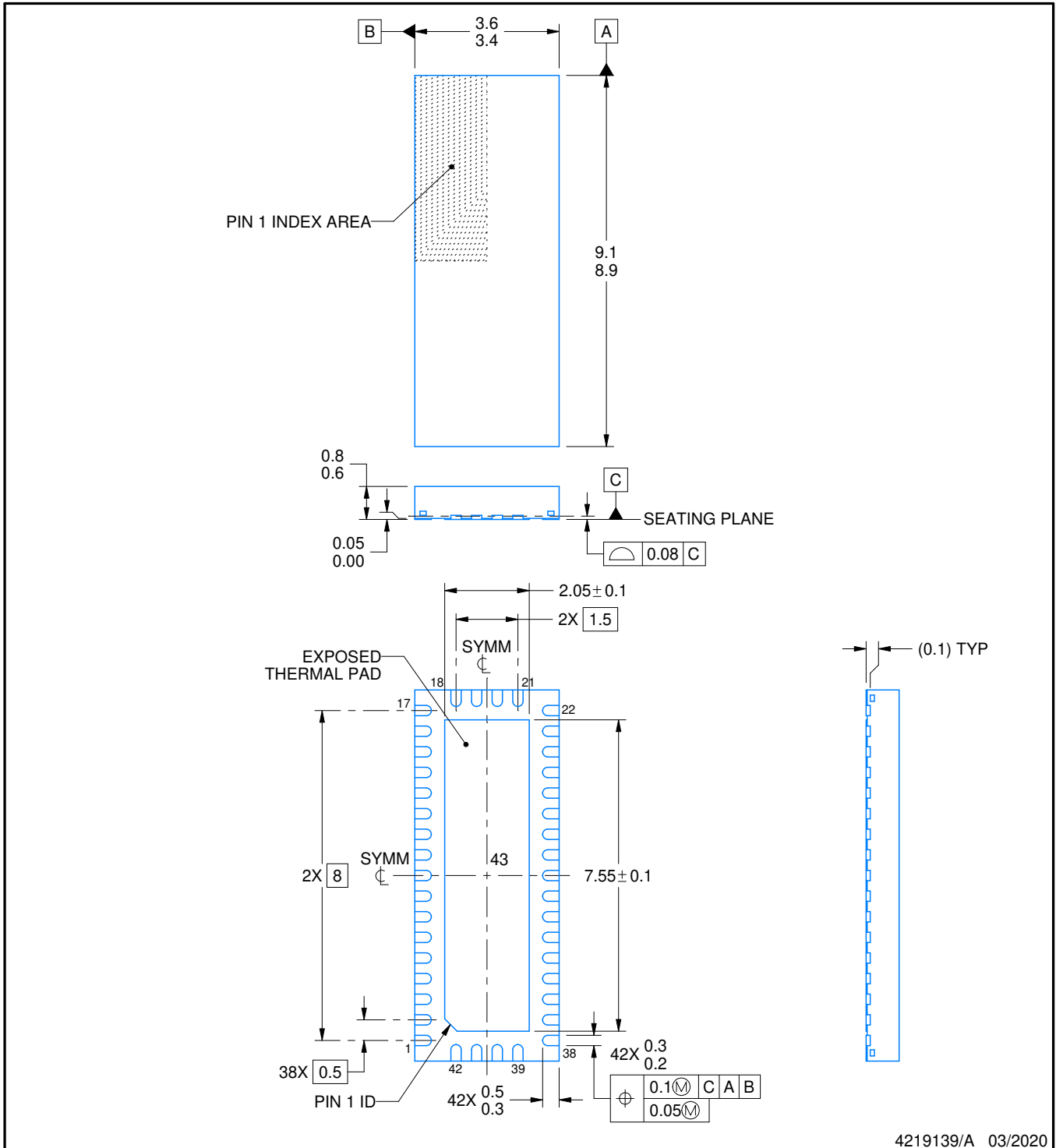

4219139/A 03/2020

NOTES:

1. All linear dimensions are in millimeters. Any dimensions in parenthesis are for reference only. Dimensioning and tolerancing per ASME Y14.5M.
2. This drawing is subject to change without notice.
3. The package thermal pad must be soldered to the printed circuit board for thermal and mechanical performance.

EXAMPLE BOARD LAYOUT

RUA0042A

WQFN - 0.8 mm max height

PLASTIC QUAD FLATPACK - NO LEAD

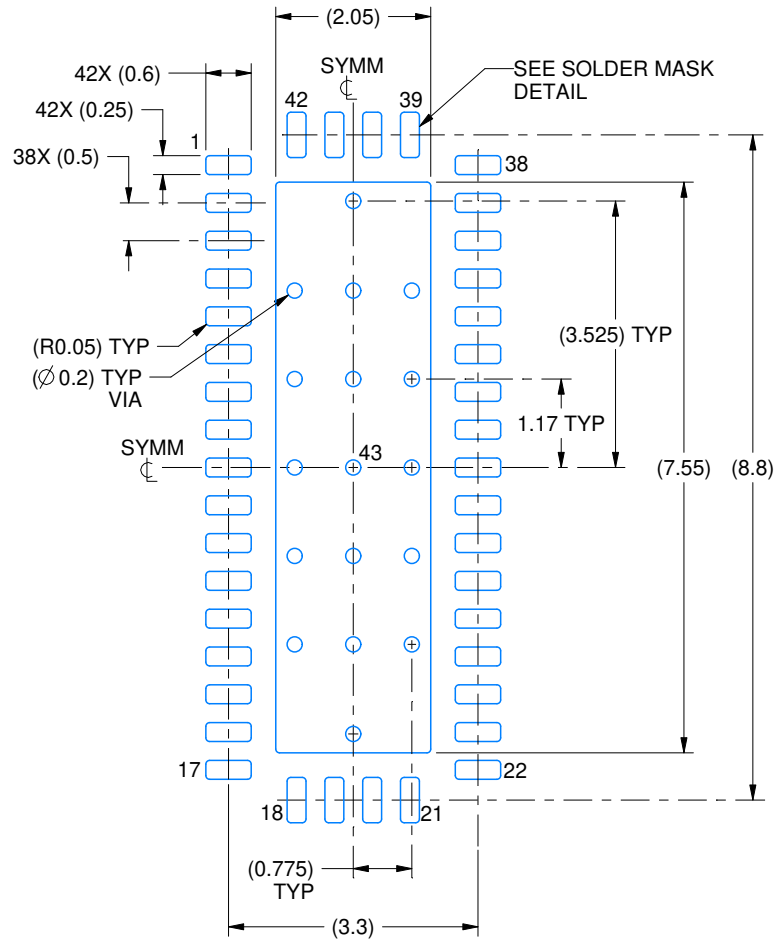

LAND PATTERN EXAMPLE
EXPOSED METAL SHOWN
SCALE: 10X

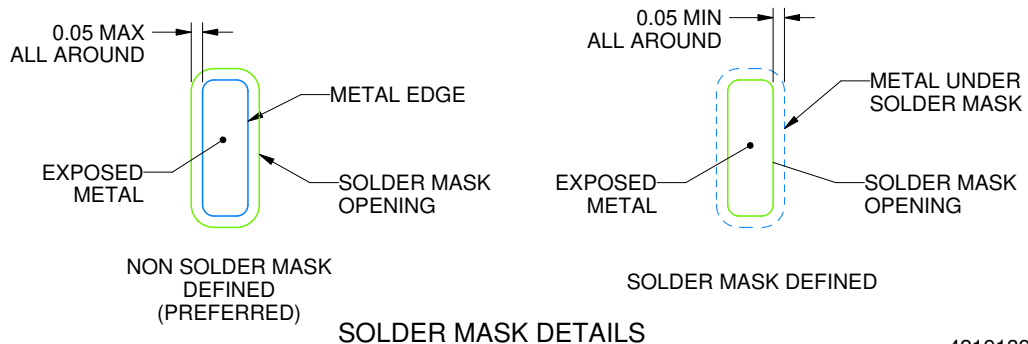

4219139/A 03/2020

NOTES: (continued)

- This package is designed to be soldered to a thermal pad on the board. For more information, see Texas Instruments literature number SLUA271 (www.ti.com/lit/sluea271).
- Vias are optional depending on application, refer to device data sheet. If any vias are implemented, refer to their locations shown on this view. It is recommended that vias under paste be filled, plugged or tented.

EXAMPLE STENCIL DESIGN

RUA0042A

WQFN - 0.8 mm max height

PLASTIC QUAD FLATPACK - NO LEAD

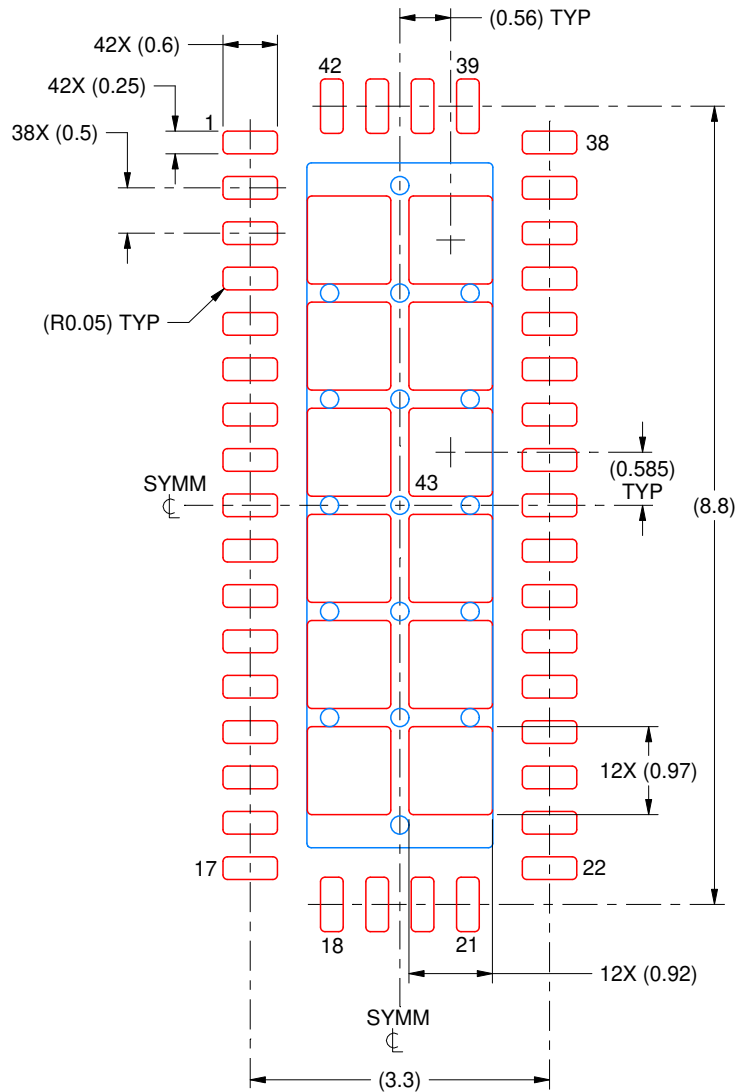

SOLDER PASTE EXAMPLE
BASED ON 0.125 MM THICK STENCIL
SCALE: 12X

EXPOSED PAD 43
69% PRINTED SOLDER COVERAGE BY AREA UNDER PACKAGE

4219139/A 03/2020

NOTES: (continued)

6. Laser cutting apertures with trapezoidal walls and rounded corners may offer better paste release. IPC-7525 may have alternate design recommendations.

IMPORTANT NOTICE AND DISCLAIMER

TI PROVIDES TECHNICAL AND RELIABILITY DATA (INCLUDING DATASHEETS), DESIGN RESOURCES (INCLUDING REFERENCE DESIGNS), APPLICATION OR OTHER DESIGN ADVICE, WEB TOOLS, SAFETY INFORMATION, AND OTHER RESOURCES "AS IS" AND WITH ALL FAULTS, AND DISCLAIMS ALL WARRANTIES, EXPRESS AND IMPLIED, INCLUDING WITHOUT LIMITATION ANY IMPLIED WARRANTIES OF MERCHANTABILITY, FITNESS FOR A PARTICULAR PURPOSE OR NON-INFRINGEMENT OF THIRD PARTY INTELLECTUAL PROPERTY RIGHTS.

These resources are intended for skilled developers designing with TI products. You are solely responsible for (1) selecting the appropriate TI products for your application, (2) designing, validating and testing your application, and (3) ensuring your application meets applicable standards, and any other safety, security, or other requirements. These resources are subject to change without notice. TI grants you permission to use these resources only for development of an application that uses the TI products described in the resource. Other reproduction and display of these resources is prohibited. No license is granted to any other TI intellectual property right or to any third party intellectual property right. TI disclaims responsibility for, and you will fully indemnify TI and its representatives against, any claims, damages, costs, losses, and liabilities arising out of your use of these resources.

TI's products are provided subject to TI's Terms of Sale (<https://www.ti.com/legal/termsofsale.html>) or other applicable terms available either on [ti.com](https://www.ti.com) or provided in conjunction with such TI products. TI's provision of these resources does not expand or otherwise alter TI's applicable warranties or warranty disclaimers for TI products.

Mailing Address: Texas Instruments, Post Office Box 655303, Dallas, Texas 75265
Copyright © 2021, Texas Instruments Incorporated