

# Future Technology Devices International UMFTPD3A Datasheet Universal programming Module

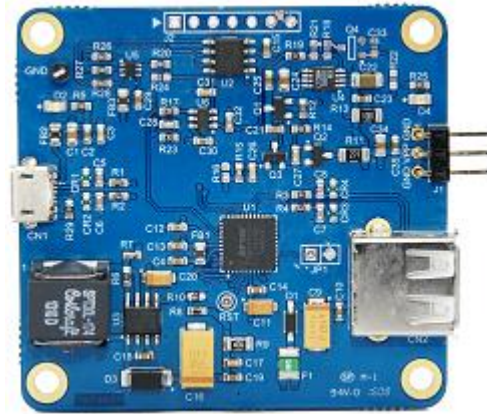

*UMFTPD3A is a universal programming module for OTP memory and eFUSE programming.*

## 1 Introduction

The UMFTPD3A Universal Programmer Module is used to provide an external programming voltage ( $V_{pp}$ ) that covers 1.5 to 6.5V to program FTDI development modules and ICs with internal OTP memory or eFUSE (electrical poly-fuse).

The embedded OTP memory or eFUSE in the FTDI chips is used to store USB Vendor ID (VID), Product ID (PID), device serial number, product description string and chip configuration information. Users can store this vendor specific information in the OTP or eFUSE and save the cost of an external EEPROM from the BOM.

The UMFTPD3A assists the user in programming the OTP memory or eFUSE directly through a USB host controller with FTDI's programming software tool, [FT\\_Prog](#).

### 1.1 Features

The UMFTPD3A has the following features:

- Micro USB-B connector allows the UMFTPD3A to be connected to a host system via a standard USB A to Micro B cable.
- Downstream port using USB-A type connector allows target devices to be connected to the UMFTPD3A.
- On board FTDI chip provides USB hub function
- Supports wide programming voltages from 1.5V to 6.5V for FT260 and FT4222H series.
- 3 pin connector to deliver VPP programming power
- Visual indicator for VPP programming voltage and USB bus power by using LEDs.
- USB2.0 Full Speed compatible.

Neither the whole nor any part of the information contained in, or the product described in this manual, may be adapted or reproduced in any material or electronic form without the prior written consent of the copyright holder. This product and its documentation are supplied on an as-is basis and no warranty as to their suitability for any particular purpose is either made or implied. Future Technology Devices International Ltd will not accept any claim for damages howsoever arising as a result of use or failure of this product. Your statutory rights are not affected. This product or any variant of it is not intended for use in any medical appliance, device or system in which the failure of the product might reasonably be expected to result in personal injury. This document provides preliminary information that may be subject to change without notice. No freedom to use patents or other intellectual property rights is implied by the publication of this document. Future Technology Devices International Ltd, Unit 1, 2 Seaward Place, Centurion Business Park, Glasgow G41 1HH United Kingdom. Scotland Registered Company Number: SC136640

## **Table of Contents**

<b>1</b>	<b>Introduction .....</b>	<b>1</b>
1.1	<b>Features.....</b>	<b>1</b>
<b>2</b>	<b>Driver Support .....</b>	<b>3</b>
<b>3</b>	<b>Ordering Information .....</b>	<b>4</b>
<b>4</b>	<b>UMFTPD3A Signals .....</b>	<b>5</b>
4.1	<b>UMFTPD3A Pin Out and connectors .....</b>	<b>5</b>
4.2	<b>J1 Signal Descriptions.....</b>	<b>6</b>
4.3	<b>USB Connectors Descriptions .....</b>	<b>6</b>
4.4	<b>LED Descriptions .....</b>	<b>6</b>
<b>5</b>	<b>Hardware Setup Guide .....</b>	<b>7</b>
5.1	<b>Module Connect to PC with USB Host .....</b>	<b>7</b>
5.2	<b>Module Connect to Device under programming .....</b>	<b>7</b>
5.3	<b>FT_PROG Programming Utility .....</b>	<b>8</b>
<b>6</b>	<b>Support Chips List .....</b>	<b>9</b>
<b>7</b>	<b>Module Dimensions .....</b>	<b>10</b>
<b>8</b>	<b>UMFTPD3A Module Circuit Schematic .....</b>	<b>11</b>
<b>9</b>	<b>Contact Information.....</b>	<b>13</b>
	<b>Appendix A – References .....</b>	<b>14</b>
	Document References .....	14
	Acronyms and Abbreviations .....	14
	<b>Appendix B – List of Figures and Tables.....</b>	<b>15</b>
	List of Figures .....	15
	List of Tables .....	15
	<b>Appendix C – Revision History .....</b>	<b>16</b>

## 2 Driver Support

Royalty free D2XX Direct Drivers (USB Drivers + DLL S/W Interface):

- Windows 10 32,64-bit
- Windows 8.1 32,64-bit
- Windows 8 32,64-bit
- Windows 7 32,64-bit

The above listed drivers are all available for download from <http://www.ftdichip.com/FTDrivers.htm>.

For driver installation instructions, refer to  
<http://www.ftdichip.com/Support/Documents/InstallGuides.htm>

### 3 Ordering Information

Module Code	Description
UMFTPD3A	Universal FTDI programmer module

## 4 UMFTPD3A Signals

### 4.1 UMFTPD3A Pin Out and connectors

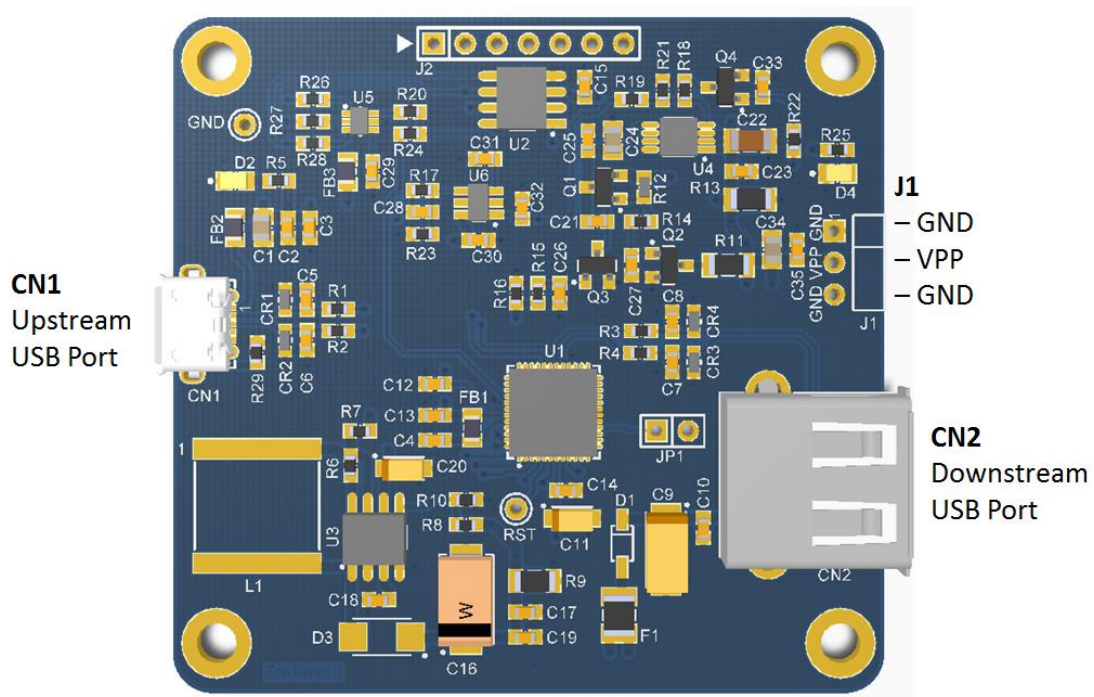

**Figure 4.1 Module Pin Out and connectors**

## 4.2 J1 Signal Descriptions

Connector Pin	Name	Type	Description
J1-1	GND	Ground	Ground 0 volts.
J1-2	VPP	Power	Programming voltage output
J1-3	GND	Ground	Ground 0 volts.

**Table 4.1 J1 Pin Out Description**

## 4.3 USB Connectors Descriptions

UMFTPD3A provides two USB connectors:

Connector No.	Description
CN1	Upstream USB port connect to the USB Host
CN2	Downstream USB port connect to the device under programming

**Table 4.2 USB connectors Description**

## 4.4 LED Descriptions

There are two LED indicators on the UMFTPD3A:

LED No.	Description
D2	USB VBUS Supply from Upstream Port
D4	VPP Power Supply

**Table 4.3 LED Description**

## 5 Hardware Setup Guide

### 5.1 Module Connect to PC with USB Host

The first time the UMFTPD3A module is connected to a Windows PC, the USB device drivers need to be installed. Windows will install the driver automatically via Windows Update if a network is connected or the driver installation package may be downloaded from the [FTDI Website](#) for manual installation.

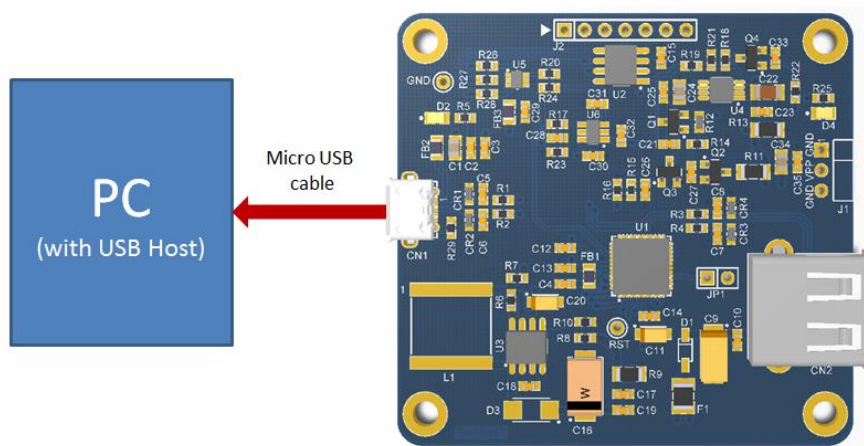

Figure 5.1 Module connected to PC with USB host

### 5.2 Module Connect to Device under programming

Figure 5.2 shows the connection between a UMFTPD3A and a target device with an FTDI chip. The UMFTPD3A is designed to control VPP power output for programming the OTP memory or eFUSE on the target board with an FTDI chip.

VPP power is supplied through the 3 pin header with 2.54mm pitch, J1.

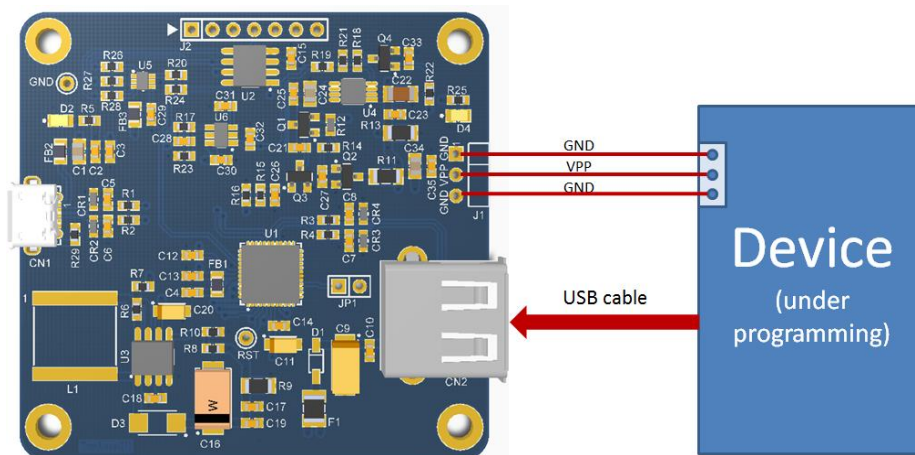

Figure 5.2 Module connected to device under programming

**Warning:** The programming connector definition may differ between FTDI development modules and 3<sup>rd</sup> party design. Please check FTDI development module datasheet or documentation for 3<sup>rd</sup> party designs before wiring the VPP connection.

**Warning:** The UMFTPD3A is only allowed to connect and program one FTDI chip at a time.

### 5.3 FT\_PROG Programming Utility

Having connected the UMFTPD3A module, the user can perform the OTP memory or eFUSE programming with the FT\_PROG utility. The FT\_PROG will detect the ICs via USB and configure the UMFTPD3A programming voltage by itself. FT\_PROG is a free programming utility for use with FTDI devices. For more details, refer to the [FTDI website](http://www.ftdi.com).

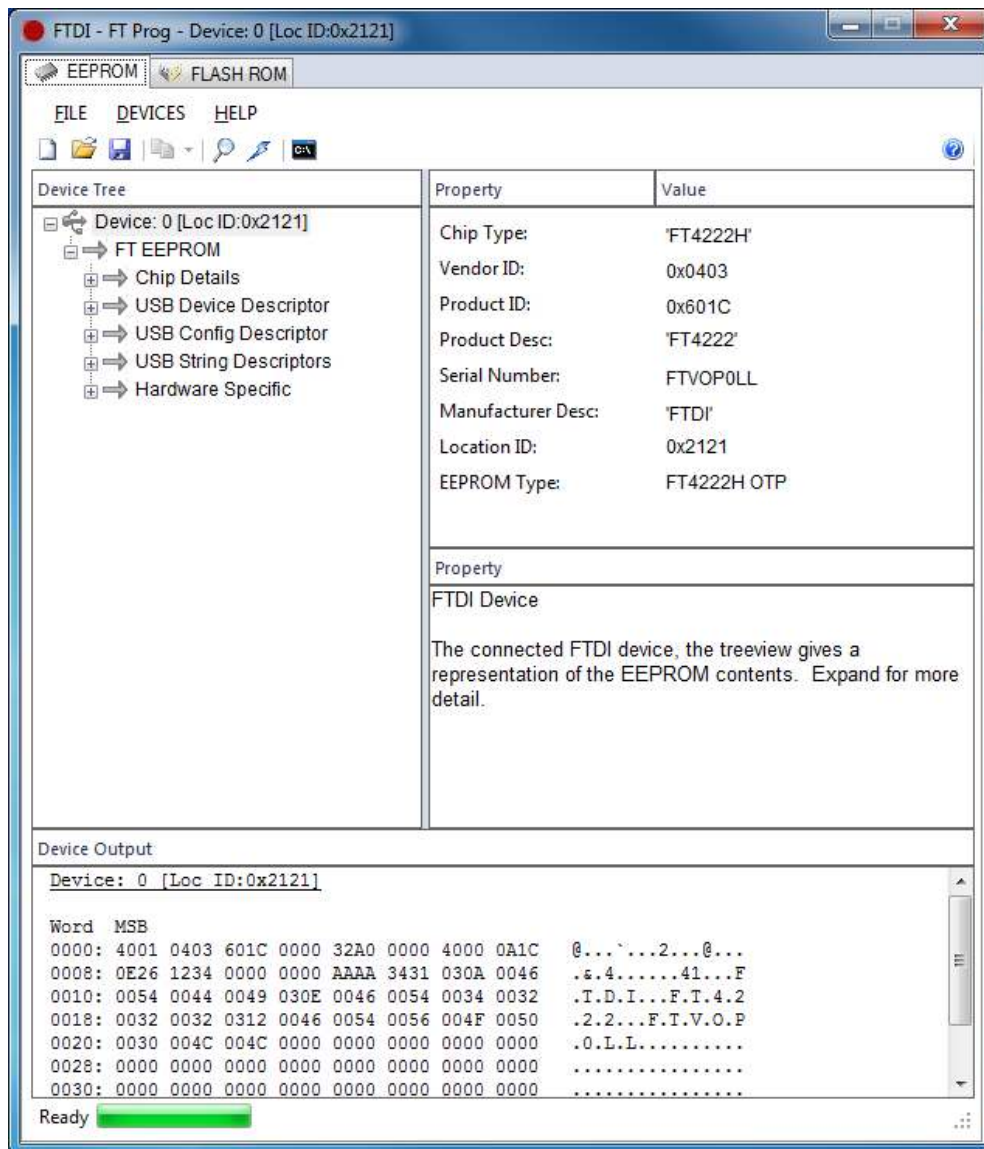

Figure 5.3 FT\_PROG example for FT4222H programming



## 6 Support Chips List

The FTDI Chips compatible with UMFTPD3A are listed below.

FTDI Chip	Memory Type	Programming voltage	Development Module
FT4222H	OTP	6.5V	UMFT4222EV
FT260	eFUSE	3.8V	UMFT260EV1A

**Table 6.1 Compatible Devices list**

## 7 Module Dimensions

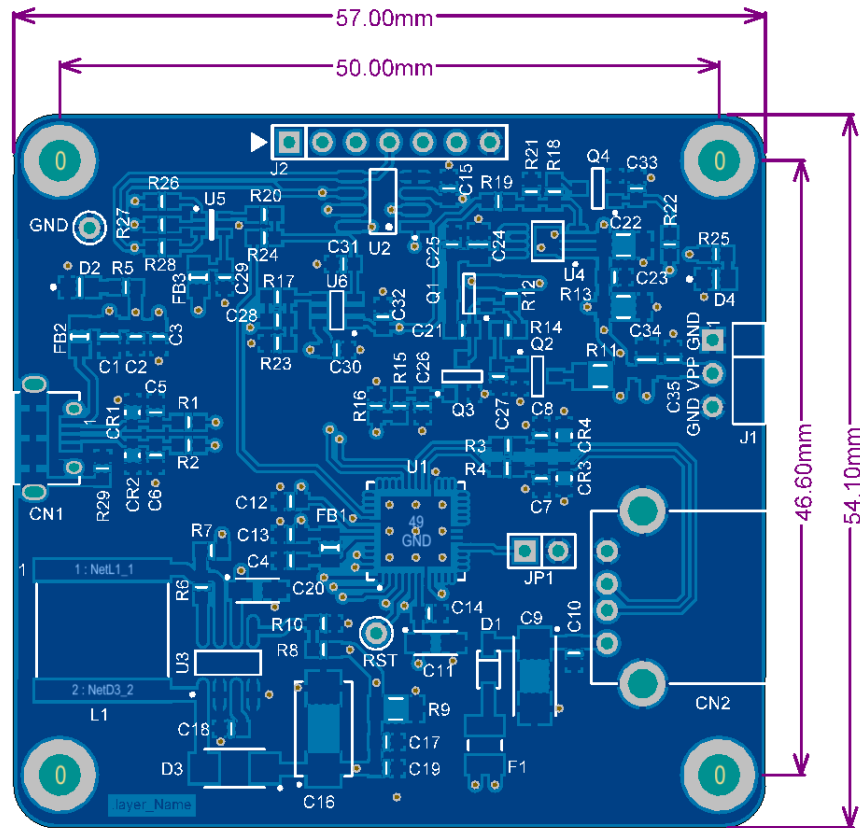

**Figure 7.1 UMFTPD3A Module Dimensions**

All dimensions are given in millimetres.

The UMFTPD3A module exclusively uses lead free components, and is fully compliant with European Union directive 2002/95/EC.





## 9 Contact Information

### Head Office – Glasgow, UK

Unit 1, 2 Seaward Place, Centurion Business Park  
Glasgow G41 1HH  
United Kingdom  
Tel: +44 (0) 141 429 2777  
Fax: +44 (0) 141 429 2758

E-mail (Sales) [sales1@ftdichip.com](mailto:sales1@ftdichip.com)  
E-mail (Support) [support1@ftdichip.com](mailto:support1@ftdichip.com)  
E-mail (General Enquiries) [admin1@ftdichip.com](mailto:admin1@ftdichip.com)

### Branch Office – Tigard, Oregon, USA

7130 SW Fir Loop  
Tigard, OR 97223  
USA  
Tel: +1 (503) 547 0988  
Fax: +1 (503) 547 0987

E-Mail (Sales) [us.sales@ftdichip.com](mailto:us.sales@ftdichip.com)  
E-Mail (Support) [us.support@ftdichip.com](mailto:us.support@ftdichip.com)  
E-Mail (General Enquiries) [us.admin@ftdichip.com](mailto:us.admin@ftdichip.com)

### Branch Office – Taipei, Taiwan

2F, No. 516, Sec. 1, NeiHu Road  
Taipei 114  
Taiwan, R.O.C.  
Tel: +886 (0) 2 8797 1330  
Fax: +886 (0) 2 8751 9737

E-mail (Sales) [tw.sales1@ftdichip.com](mailto:tw.sales1@ftdichip.com)  
E-mail (Support) [tw.support1@ftdichip.com](mailto:tw.support1@ftdichip.com)  
E-mail (General Enquiries) [tw.admin1@ftdichip.com](mailto:tw.admin1@ftdichip.com)

### Branch Office – Shanghai, China

Room 1103, No. 666 West Huaihai Road,  
Shanghai, 200052  
China  
Tel: +86 (0)21 6235 1596  
Fax: +86 (0)21 6235 1595

E-mail (Sales) [cn.sales@ftdichip.com](mailto:cn.sales@ftdichip.com)  
E-mail (Support) [cn.support@ftdichip.com](mailto:cn.support@ftdichip.com)  
E-mail (General Enquiries) [cn.admin@ftdichip.com](mailto:cn.admin@ftdichip.com)

### Web Site

<http://ftdichip.com>

### Distributor and Sales Representatives

Please visit the Sales Network page of the [FTDI Web site](#) for the contact details of our distributor(s) and sales representative(s) in your country.

System and equipment manufacturers and designers are responsible to ensure that their systems, and any Future Technology Devices International Ltd (FTDI) devices incorporated in their systems, meet all applicable safety, regulatory and system-level performance requirements. All application-related information in this document (including application descriptions, suggested FTDI devices and other materials) is provided for reference only. While FTDI has taken care to assure it is accurate, this information is subject to customer confirmation, and FTDI disclaims all liability for system designs and for any applications assistance provided by FTDI. Use of FTDI devices in life support and/or safety applications is entirely at the user's risk, and the user agrees to defend, indemnify and hold harmless FTDI from any and all damages, claims, suits or expense resulting from such use. This document is subject to change without notice. No freedom to use patents or other intellectual property rights is implied by the publication of this document. Neither the whole nor any part of the information contained in, or the product described in this document, may be adapted or reproduced in any material or electronic form without the prior written consent of the copyright holder. Future Technology Devices International Ltd, Unit 1, 2 Seaward Place, Centurion Business Park, Glasgow G41 1HH, United Kingdom. Scotland Registered Company Number: SC136640

## Appendix A – References

### Document References

#### Application Notes

[AN\\_124 User Guide for FTDI FT\\_Prog Utility](#)

#### Datasheets

[DS\\_FT4222H](#)

[DS\\_UMFT4222EV](#)

[DS\\_FT260](#)

[DS\\_UMFT260EV](#)

#### FT\_PROG Utility

[http://www.ftdichip.com/Support/Utilities.htm#FT\\_Prog](http://www.ftdichip.com/Support/Utilities.htm#FT_Prog)

### Acronyms and Abbreviations

Terms	Description
eFUSE	Electrical poly fuse
OTP	One Time Programming
USB	Universal Serial Bus

## **Appendix B – List of Figures and Tables**

### **List of Figures**

Figure 4.1 Module Pin Out and connectors .....	5
Figure 5.1 Module connect to PC with USB host .....	7
Figure 5.2 Module connect to device under programming.....	7
Figure 5.3 I/O voltage level with internal regulator: JP1 shorted .....	8
Figure 6.1 UMFTPD3A Module Dimensions.....	10
Figure 7.1 Module Circuit Schematic.....	11

### **List of Tables**

Table 4.1 J1 Pin Out Description .....	6
Table 4.2 USB connectors Description .....	6
Table 4.3 LED Description .....	6
Table 6.1 Compatible Devices list.....	9

## Appendix C – Revision History

Document Title: UMFTP3A Datasheet  
Document Reference No.: FT\_001318  
Clearance No.: FTDI# 502  
Product Page: <http://www.ftdichip.com>  
Document Feedback: [Send Feedback](#)

Revision	Changes	Date
Version 1.0	Initial Release	2016-05-23