

REVISIONS					
P	LTR	DESCRIPTION	DATE	DMN	APVD
B		REVISED PER ECO-08-023819	25SEP08	HMR	MS
C		REVISED PER ECO-17-001607	16MAY2017	RK	PO

SPECIFICATIONS

MATERIALS:
CASE, PPS UL94V-0, BLACK
COVER, PBT UL94V-0, BLACK
ACTUATOR, 46 NYLON UL94V-0, WHITE
TERMINAL/FIXED CONTACT-COPPER ALLOY- GOLD OVER NICKEL PLATE
MOVING CONTACT-COPPER ALLOY- GOLD FLASH OVER NICKEL PLATE

ELECTRICAL:
RATING- 1a max non-switching
0.1µA (1mV) min switching
DC 5V 10mA
INITIAL CONTACT RESISTANCE- 50milliohm max. (300 milliohms after test)
INSULATION RESISTANCE- 100Megohms min. at 100V DC
DIELECTRIC STRENGTH- 300V RMS@SEA LEVEL
LIFE EXPECTANCY- 1,000 CYCLES

MECHANICAL:
ACTUATION FORCE- 2.45 +/-1.47N (245 +/-147 GF)
TRAVEL- 33°

ENVIRONMENTAL:
OPERATING TEMPERATURE- -30 TO +85 DEGREES C
STORAGE TEMPERATURE- -45 TO +100 DEGREES C
RESISTANCE TO SOLDER HEAT- 265 +/--3°C for 8 +/-2 seconds
SOLDERABILITY PER JIS-C-0050 & JIS-C-0053

- 1 ALL MATERIALS AND FINISHES SHALL COMPLY WITH EU DIRECTIVE 2002/95/EC OF 27JAN2003 (ROHS)
- 2 SWITCH SUPPLIED IN THE "OFF" POSITION AND SHOULD BE SOLDERED IN THE "OFF" POSITION.

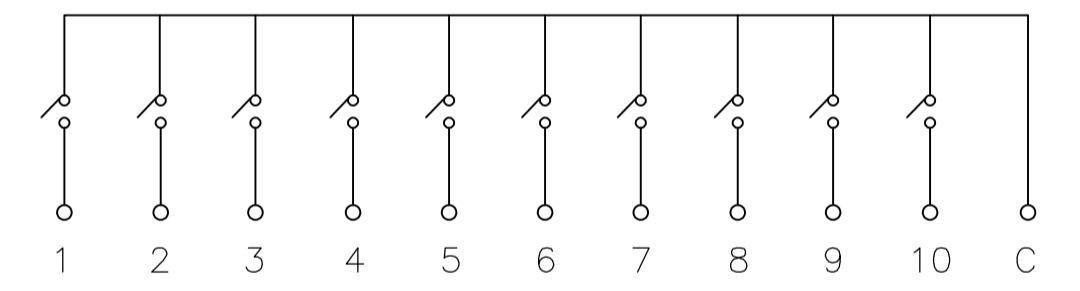
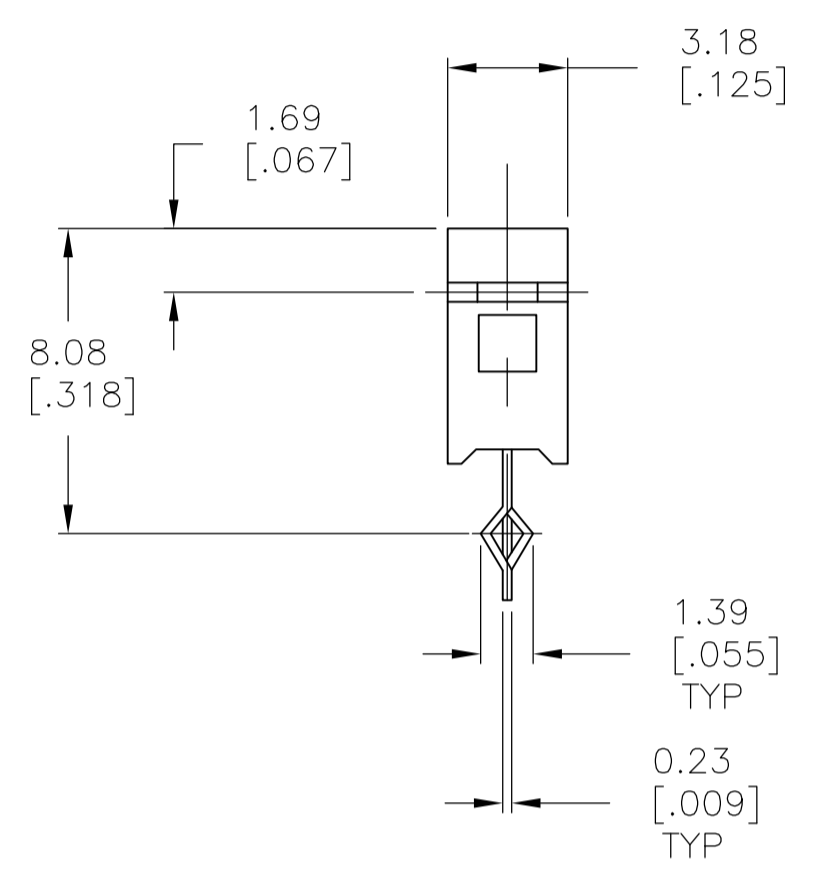
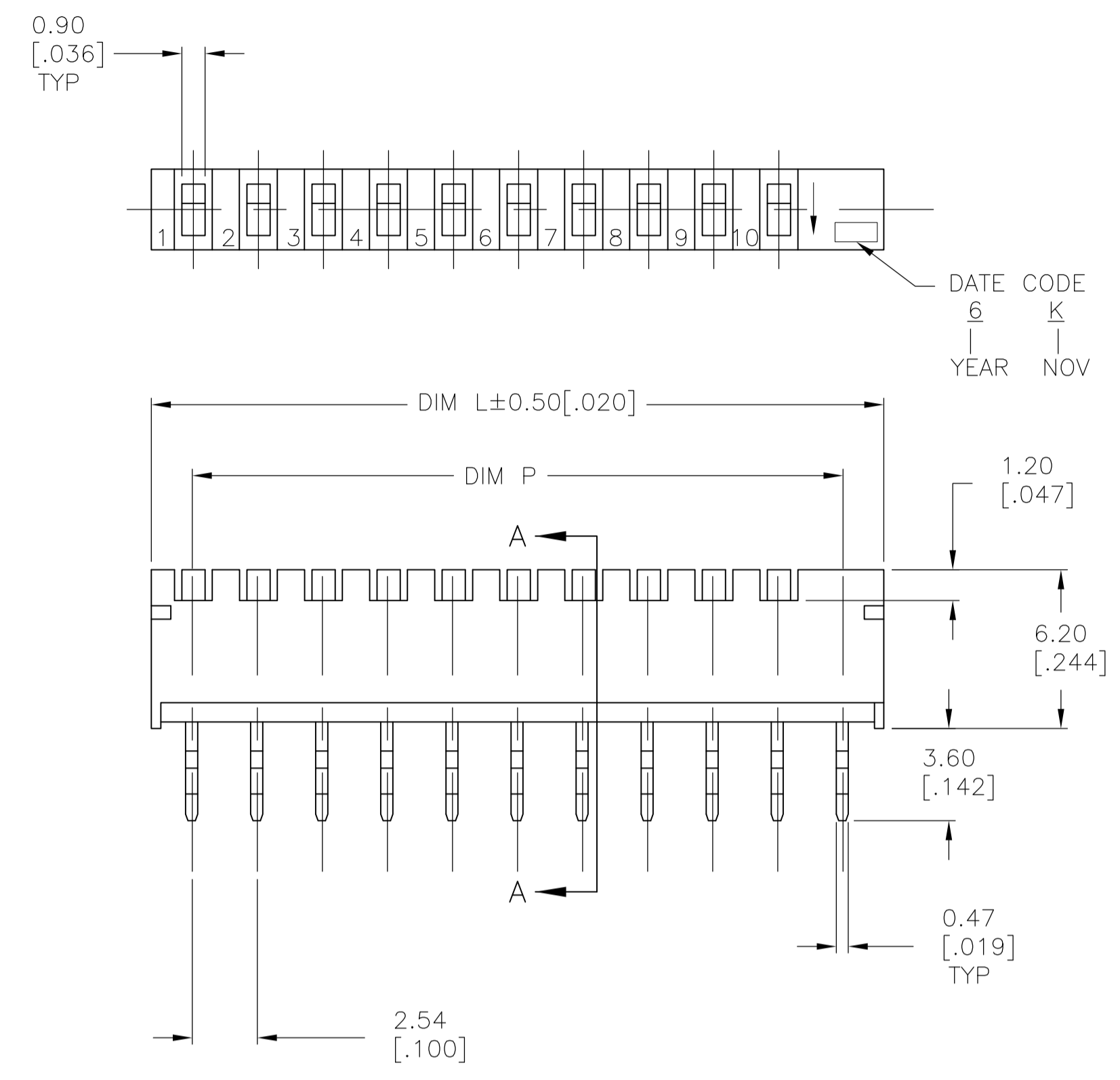

CIRCUIT DIAGRAM

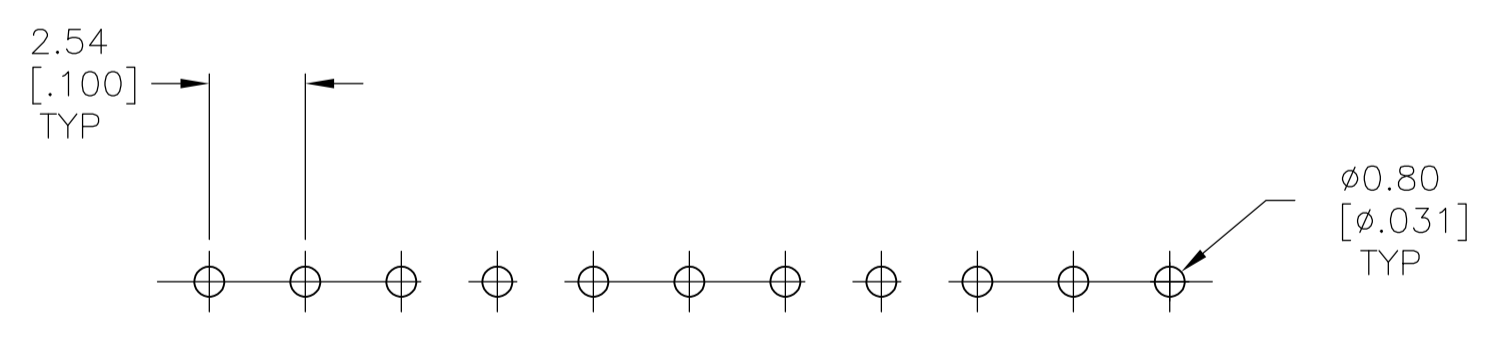

P.C. LAYOUT

OBsolete	Terminals	Dim P (mm)	Dim L (mm)	Part No.	Part Number
	1, 2, 10 & C	25.40 (.800)	28.60 (1.126)	STV10	1977104-5
	1, 2, 8, & C	20.32 (.800)	23.52 (.926)	STV08	1977104-4
	1, 2, 6 & C	15.24 (.600)	18.44 (.726)	STV06	1977104-3
	ALL	10.16 (.400)	13.36 (.526)	STV04	1977104-2
	ALL	5.08 (.200)	8.28 (.326)	STV02	1977104-1
	KINKED TERMINALS	DIM P	DIM L	T&B P/N	PART NUMBER

THIS DRAWING IS A CONTROLLED DOCUMENT. **STE** TE Connectivity

DIMENSIONS: mm [INCHES]	TOLERANCES UNLESS OTHERWISE SPECIFIED:	DIN M. BINNER 16MAY07	CHK: M. S. SARVER	NAME: SIP SWITCH (STV02 - 10 SERIES)
0 PLC ± -	1 PLC ± -	PRODUCT SPEC	APVD	SIZE: A1
2 PLC ± 0.30 [0.012]	3 PLC ± -	APPLICATION SPEC	WEIGHT	CAGE CODE: 00779
4 PLC ± -	ANGLES ± -	MATERIAL: SEE SPECIFICATIONS	FINISH: -	DRAWING NO: 1977104
CUSTOMER DRAWING		SCALE: 5:1		SHEET: 1 OF 1