



ALAN210001



18.3 x 12.4 x 6.4 mm
RoHS/RoHS II Compliant
MSL = 1

Features

- Meets IEEE 802.3at standards
- Supports speed up to 1 Gbps
- Power Over Ethernet up to 30 Watts
- Current capability up to 600 mA
- Operating temperature range up to -40°C to +125°C
- Compatible with major IC's for Ethernet applications
- High performance magnetics for EMI suppression and common mode noise rejection
- 1CT:1CT TX and RX Transformers

Applications

- Fast and gigabit Ethernet
- Hubs, servers, switches, routers, access points
- IP cameras, surveillance, and phone
- Industrial computers and robotics
- Networking and communications
- Broadcast video
- Set top box

Part Identification

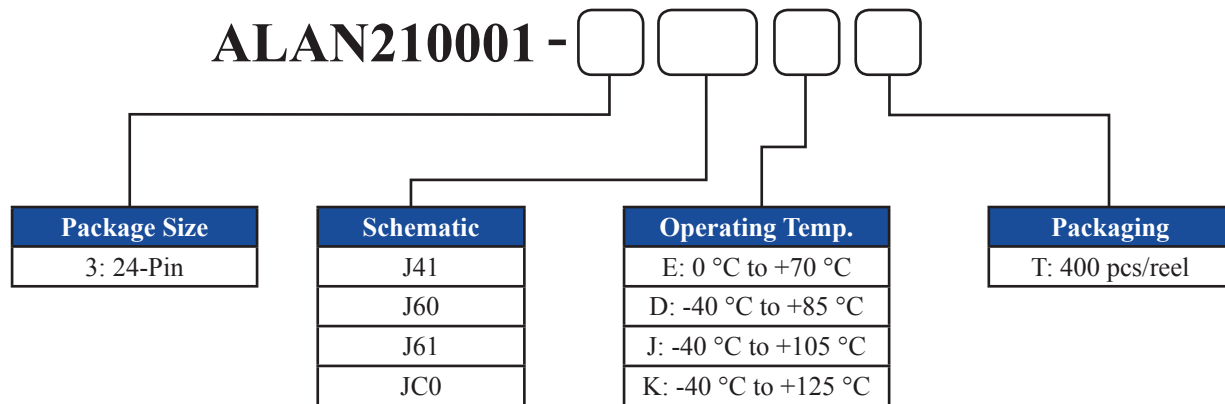

POE+ 10/100/1000 BASE-T Single Port SMD LAN Transformer Module



ALAN210001



18.3 x 12.4 x 6.4 mm
RoHS/RoHS II Compliant
MSL = 1

Electrical Specifications at 25°C

Part Number	Insertion Loss (dB Max)		Return Loss (dB Min)				Crosstalk (dB Min)			CMRR (dB Min)			DCMR (dB Min)		
	0.3-100 MHz	125 MHz	0.5-30 MHz	40-60 MHz	60-80 MHz	100 MHz	30 MHz	50 MHz	100 MHz	30 MHz	60 MHz	100 MHz	30 MHz	60 MHz	100 MHz
ALAN210001-3J41	1.2	2.0	16	14	12	10	35	28	23	55	36	31	43	36	31
ALAN210001-3J60	1.2	2.0	16	14	12	10	35	28	23	55	36	31	43	36	31
ALAN210001-3J61	1.2	2.0	16	14	12	10	35	28	23	55	36	31	43	36	31
ALAN210001-3JC0	1.2	2.0	16	14	12	10	35	28	23	55	36	31	43	36	31

Part Number	Inductance (uH Min)	Leakage Inductance (uH Max)	Interwinding Capacitance (pF Max)	DC Resistance (Ω Max)		Hi Pot (Vrms)	Weight (g)
				Primary	Secondary		
Test Condition	@100kHz, 0.2V, 8mA DC Bias	@100kHz, 0.1V TD to MX	@100kHz, 0.1V TD to MX			6 sec.	Per Piece
ALAN210001-3J41	350	0.5	35	1.0	1.0	1500	2.1
ALAN210001-3J60	350	0.5	35	1.2	1.0	1500	2.1
ALAN210001-3J61	350	0.5	35	1.2	1.0	1500	2.1
ALAN210001-3JC0	350	0.5	35	1.0	1.2	1500	2.1

Standard	Current (mA Max)	Voltage (V)	Power Delivered per Port (W Max)
IEEE 802.3at : Type-2 / POE+	600	@57 V Continuous	30



ALAN210001



18.3 x 12.4 x 6.4 mm
RoHS/RoHS II Compliant
MSL = 1

Mechanical Dimensions

3: 24-pin

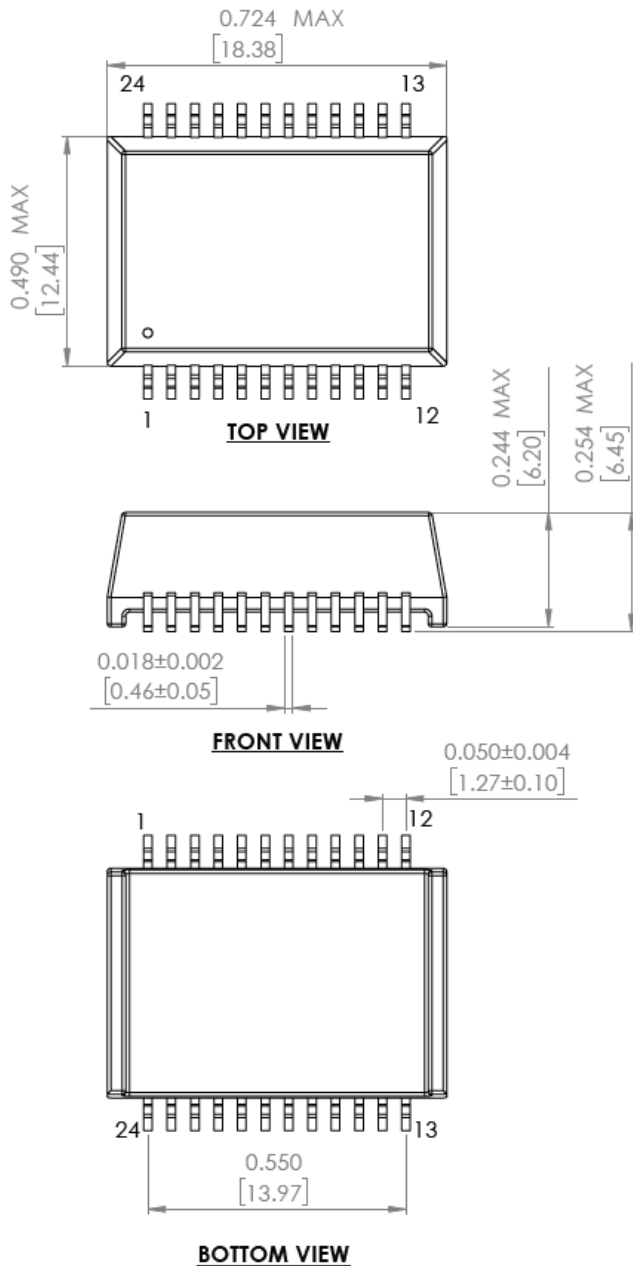

RECOMMENDED LAND PATTERN

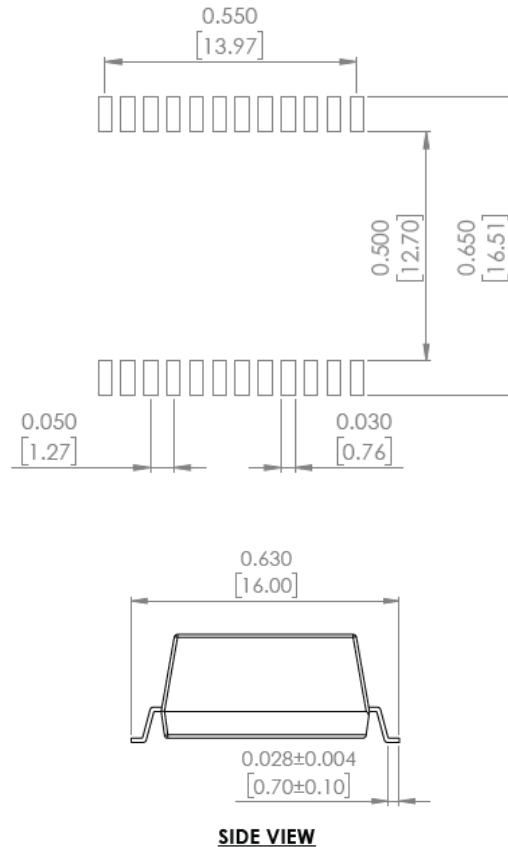

Unless otherwise specified, all tolerances are ±0.010 [0.25]
Dimensions: inch [mm]



ALAN210001



18.3 x 12.4 x 6.4 mm
RoHS/RoHS II Compliant
MSL = 1

Schematics

24-Pin

J41

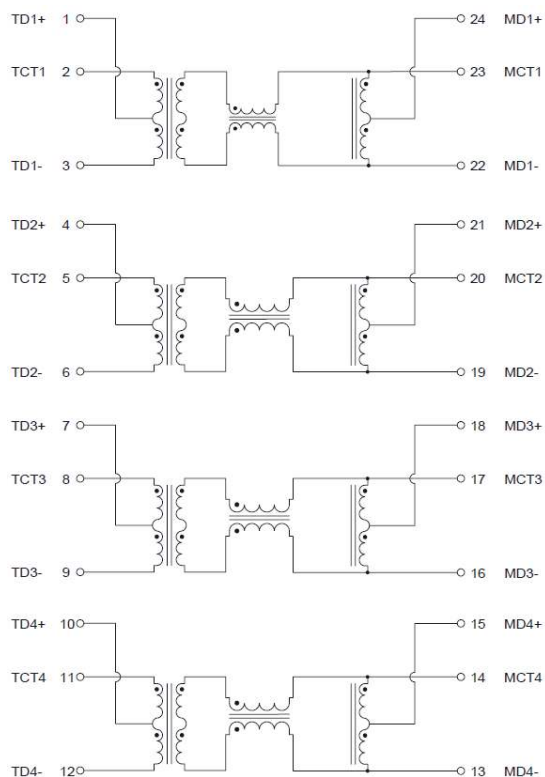

J60

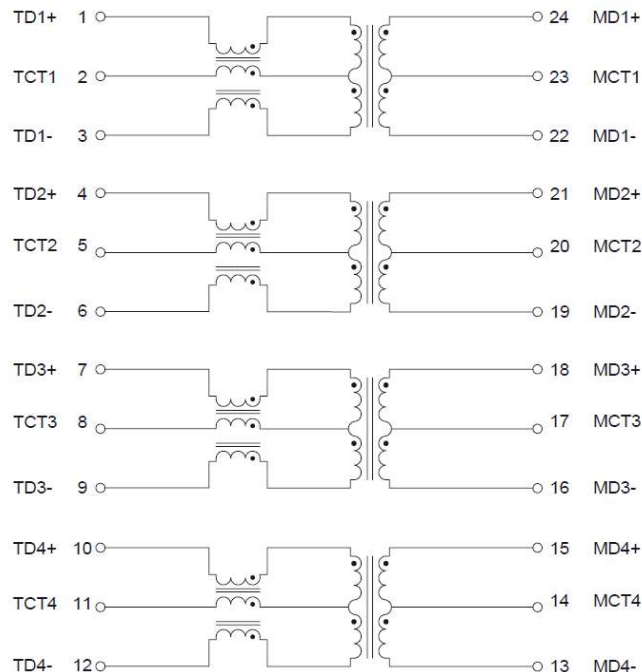

Contact Abracon for additional options.



5101 Hidden Creek Ln Spicewood TX 78669
Phone: 512-371-6159 | Fax: 512-351-8858
For terms and conditions of sales, please visit:
www.abracon.com

REVISED: 09-4-19

ABRACON IS
ISO9001-2015
CERTIFIED



ALAN210001



18.3 x 12.4 x 6.4 mm
RoHS/RoHS II Compliant
MSL = 1

Schematics

24-Pin

J61

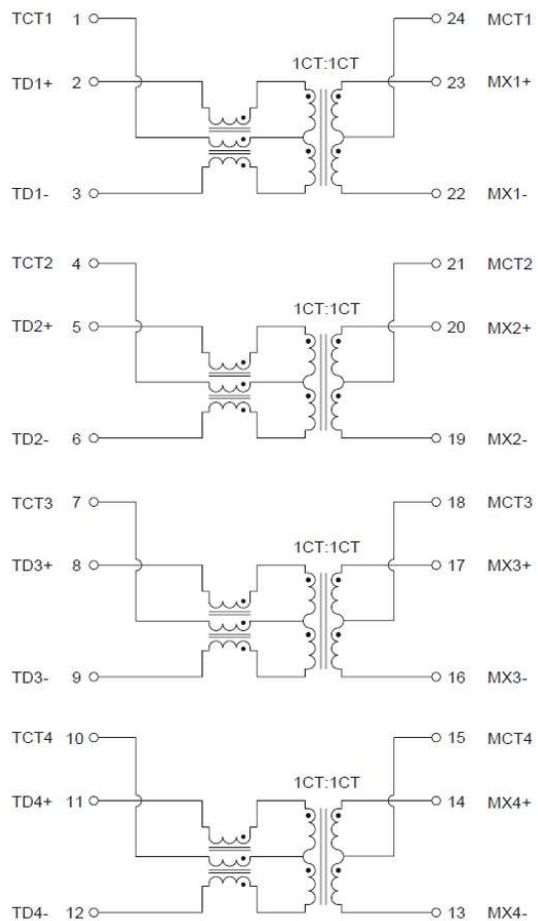

JC0

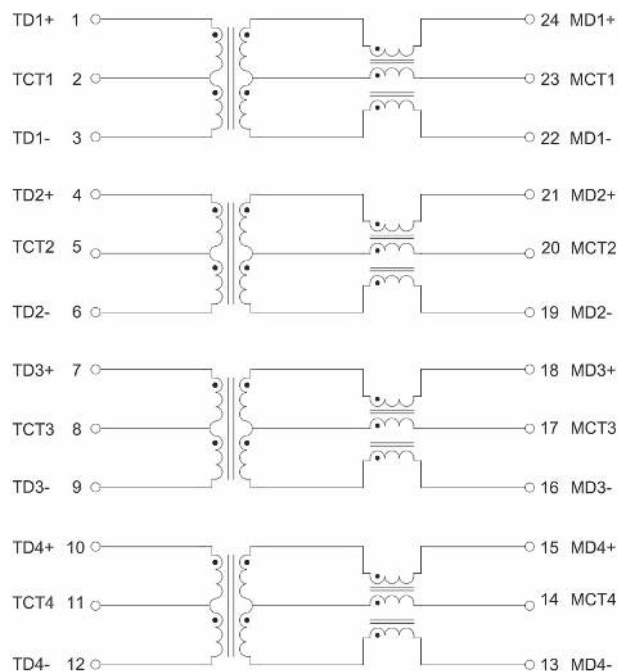

Contact Abracon for additional options.



ALAN210001



18.3 x 12.4 x 6.4 mm
RoHS/RoHS II Compliant
MSL = 1

Reflow Profile

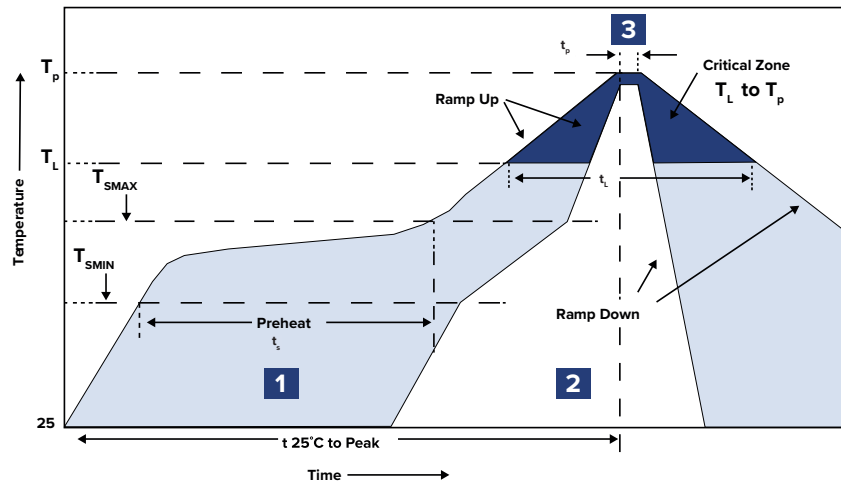

Zone	Description	Temperature	Time
1	Preheat / Soak	T_S 150 °C ~ 200 °C	t_s 60 ~ 120 sec.
2	Reflow	T_L 217 °C	t_L 60 ~ 150 sec.
3	Peak heat	T_p 245 ± 5 °C	t_p 20 ~ 40 sec.

POE+ 10/100/1000 BASE-T Single Port SMD LAN Transformer Module



ALAN210001



18.3 x 12.4 x 6.4 mm
RoHS/RoHS II Compliant
MSL = 1

Packaging

Tape and Reel: 400 pcs/reel
 Pieces per Carton: 3,200
 T&R per Carton: 8
 Weight per Carton: 11.5 kg
 Weight per Piece: 2.1 g
 Dimension of the carton: 365 x 365 x 350 mm

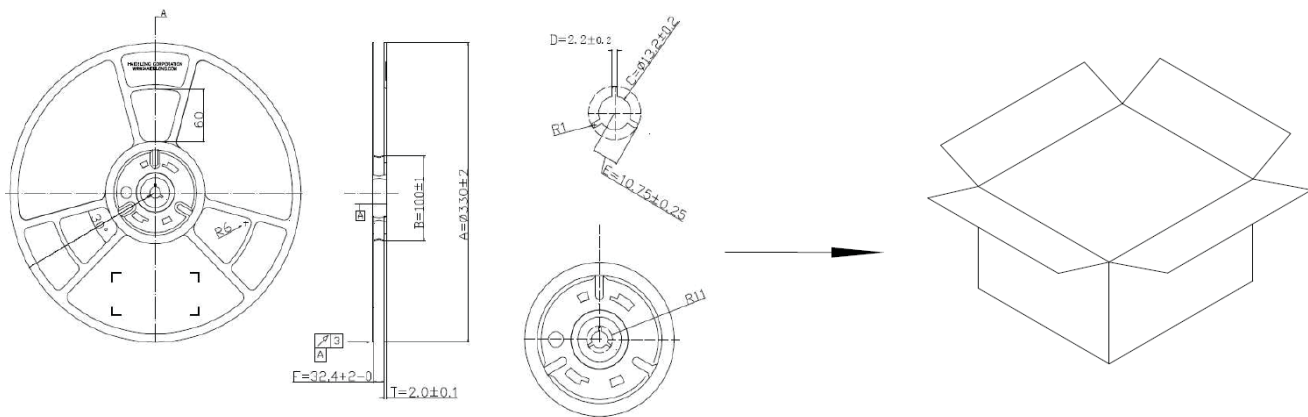
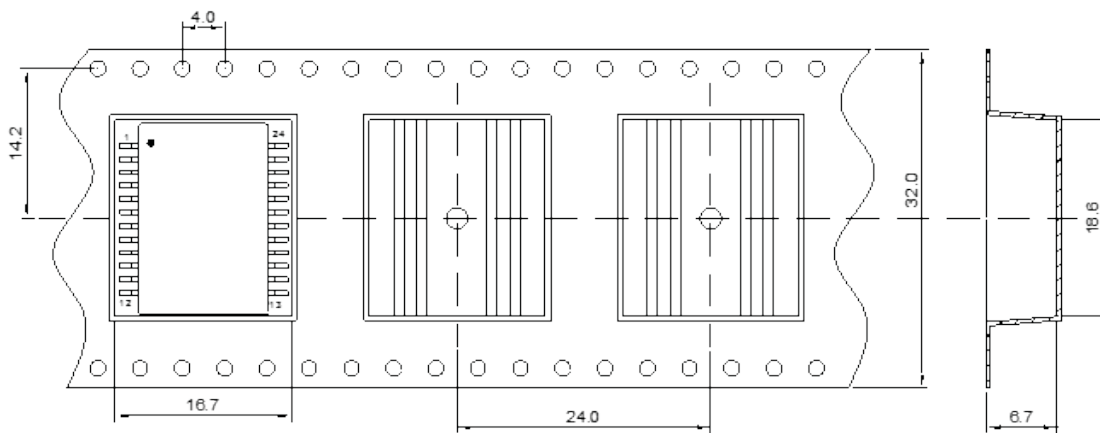

Dimensions: mm

ATTENTION: Abracon LLC's products are COTS – Commercial-Off-The-Shelf products; suitable for Commercial, Industrial and, where designated, Automotive Applications. Abracon's products are not specifically designed for Military, Aviation, Aerospace, Life-dependent Medical applications or any application requiring high reliability where component failure could result in loss of life and/or property. For applications requiring high reliability and/or presenting an extreme operating environment, written consent and authorization from Abracon LLC is required. Please contact Abracon LLC for more information.



5101 Hidden Creek Ln Spicewood TX 78669
 Phone: 512-371-6159 | Fax: 512-351-8858
 For terms and conditions of sales, please visit:
www.abracon.com

REVISED: 09-4-19

ABRACON IS
 ISO9001-2015
 CERTIFIED