

Series 35-7 PCB-Tainer

CONNECT AND PROTECT

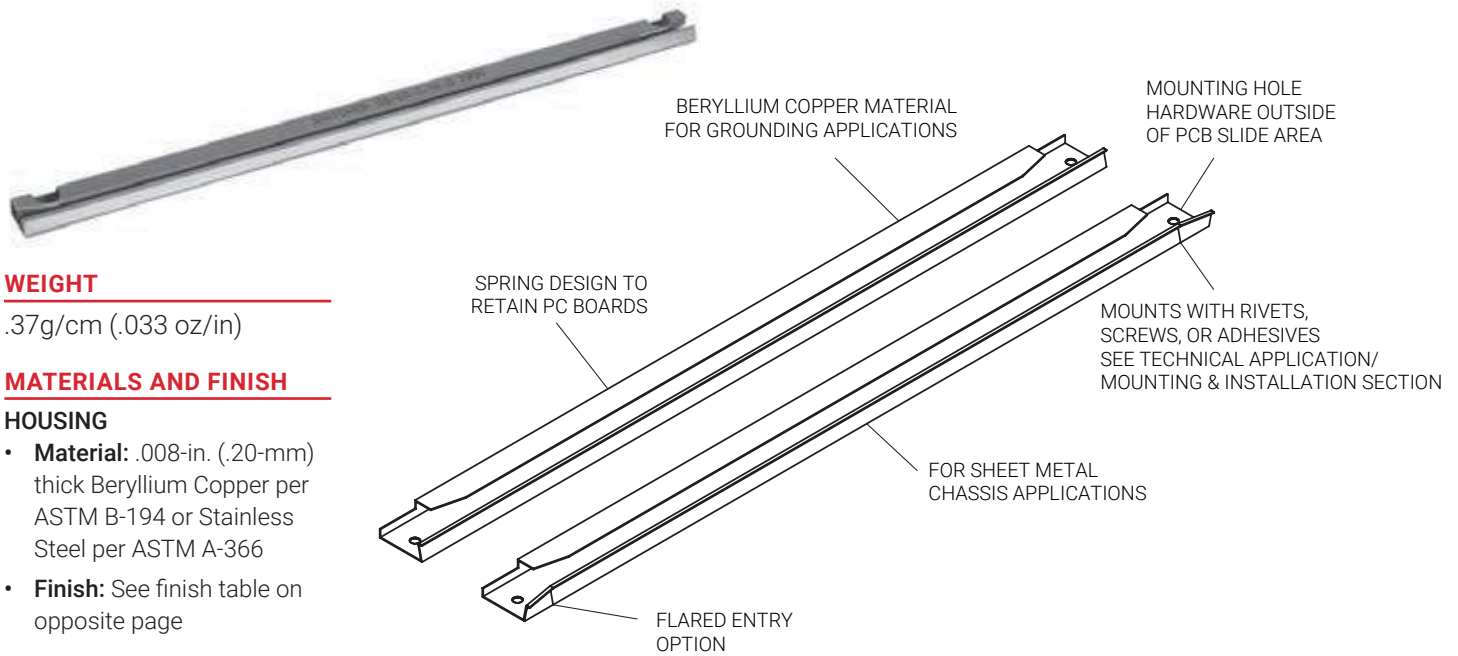

WEIGHT

.37g/cm (.033 oz/in)

MATERIALS AND FINISH

HOUSING

- **Material:** .008-in. (.20-mm) thick Beryllium Copper per ASTM B-194 or Stainless Steel per ASTM A-366
- **Finish:** See finish table on opposite page

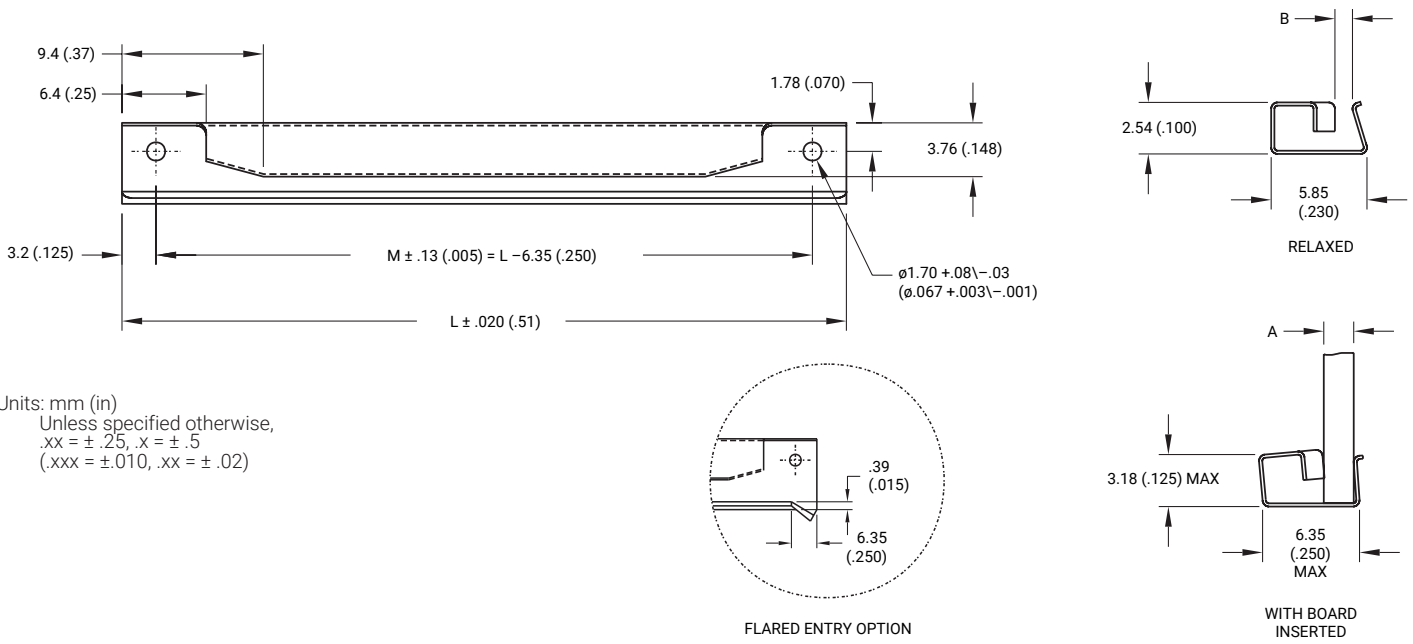

Units: mm (in)
 Unless specified otherwise,
 .xx = ± .25, .x = ± .5
 (.xxx = ±.010, .xx = ± .02)

Part Number Code	
Series 35-7 PCB-TAINER	35 C F -7 B -2 -10 -5
Center Mounting Hole	
Center Mounting Hole _____ C	
None _____ [Blank]	
Flared Entry	
Flared Entry: _____ F	
None: _____ [Blank]	
Material	
Beryllium Copper _____ B	
or select from Materials Table	
Board Thickness	
1.59 (.063) PCB Thickness _____ 2	
or select from Dimension Table	
Length	
Length in 12.7 (.50) increments _____ 2 [25.4 (1.00)]	
_____ to 12 [152.4 (6.00)]	
Finish	
Gold Plate _____ 5	
or select from Finish Table	
No dash number required for CR material. Stainless steel parts are passivated only.	

Part Number Code example:

35-7B-3-12-6

35 Series PCB-TAINER, Beryllium Copper, 2.38-mm (.093-in.) thick board, 152.4-mm (6.00-in.) long, Nickel plate finish.

MATERIALS TABLE

CODE LETTER	MATERIAL
B	BERYLLIUM COPPER, 1/4H PER ASTM-B-194
BH	BERYLLIUM COPPER, 1/4HT PER QQ-C-533, HEAT TREATED
CR	STAINLESS STEEL, TYPE 301 COND 1/4 H PER AMS 5517

BOARD THICKNESS TABLE

	BOARD THICKNESS	RELAXED +.00/- .38(+.000/- .015)
DASH #	A	B
-1	0.79 (.031)	4.58 (.180)
-2	1.59 (.063)	4.58 (.180)
-3	2.38 (.094)	4.58 (.180)

FINISH TABLE

DASH #	MATERIAL
[Blank]	SILVER PLATE PER QQ-S-365, TYPE III, GRADE A
-1	NONE
-2	EBANOL PER MIL-F-495 FOR BERYLLIUM COPPER PER MIL-C-13924 FOR STEEL
-3	CADMIUM PER QQ-P-416, TYPE 2, CLASS 2
-4	COPPER PLATE PER MIL-C-14550, CLASS 2
-5	GOLD PLATE PER MIL-G-45204, TYPE 1, GLASS 1
-6	NICKEL PLATE PER QQ-N-290, CLASS 1, GRADE G, BRIGHT
-7	ZINC PLATE CLEAR CHROMATE, PER ASTM-B-633, Fe/Zn 8
-8	ZINC PLATE YELLOW CHROMATE, PER ASTM-B-633, Fe/Zn 8

nVent SCHROFF, Inc.

7328 Trade Street San Diego,
CA 92121 USA
+1 800-525-4682

BIRTCHER™



Our powerful portfolio of brands:

CADDY ERICO HOFFMAN RAYCHEM SCHROFF TRACER