

REV.	DESCRIPTION	RELEASED	DATE	APPROVED
A	UPDATED DRAWING		97/04/10	RS
B	RELEASED TO PRODUCTION		97/05/20	RS
C	VIBRATION WAS SINE. LIFE AT RATED LOAD ADDED. REF. GRUWMAN ADDED		97/08/22	RS
D	TRIP PTS. 60 AMP WAS 75. 300 AMP WAS 250. 4.0-6.0 WAS 1.2-2.0. 2.0-3.0 WAS 0.34-0.65		98/03/16	RS
E	08-07-1322 3.26 DIM. WAS 3.23		08/10/13	CB

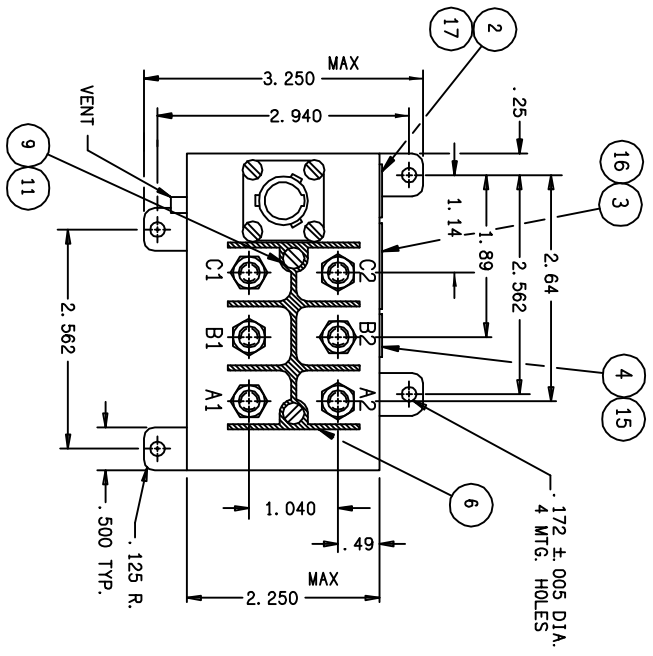

NOTE: FOR PROPER OPERATION, PIN A REQUIRES 18 TO 28 VDC

CONSTRUCTION
MAIN CONTACTS
VOLTAGE (NOM.)
CURRENT RES.
MOTOR RPTURE
OPERATE TIMES:
CLOSING
TRIPPING
OPENING
CONTACTS
CONFIGURATION
RESISTANCE
RES. IND.

AUXILIARY CONTACTS
CONFIGURATION
RESISTANCE
RES. IND.

COIL DATA
DUTY CYCLE
MIN. OPER. VOLTAGE
MAX. OPER. VOLTAGE
RESISTANCE

ENVIRONMENTAL DATA
OPERATING TEMP.
VIBRATION: RANDOM
SHOCK
ALTITUDE
LIFE MECHANICAL
LIFE AT RATED LOAD
WEIGHT MAX.

TRIP POINTS
CURRENT ±10%
60 AMP
150 AMP
300 AMP
500 AMP

TRIP TIME (SECONDS)
8.0 TO 10.0
4.0 TO 6.0
2.0 TO 3.0
0.07 TO 0.20

GASKET SEALED (VENTED)
3PST SIDE STABLE
115/208 VAC 400 - 610 HZ
50 AMP 50,000 CYCLES
50 AMP 50,000 CYCLES
500 AMP

SPDT
28 VDC 115 VAC 400 - 610 HZ
5 AMP
3 AMP

CONTINUOUS ECONOMIZED
18VDC AT 85°C
32 VDC
PICKUP - 5.7 OHMS ± 10%
HOLD - 72.0 OHMS ± 10%

-55°C TO +85°C
PER GR835AAU
50g MAX, 10-12 MS SAWTOOTH
60,000 FT. MAX
100,000 CYCLES MIN.
50,000 CYCLES MIN.
1.55 LBS.

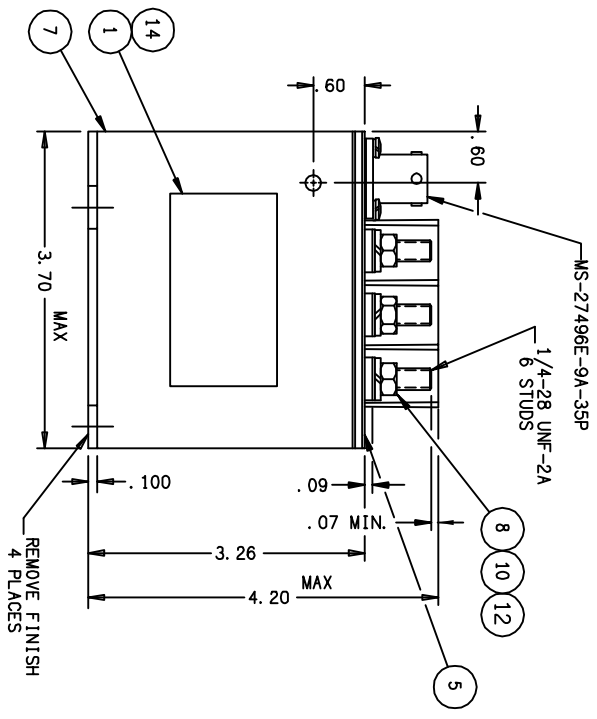
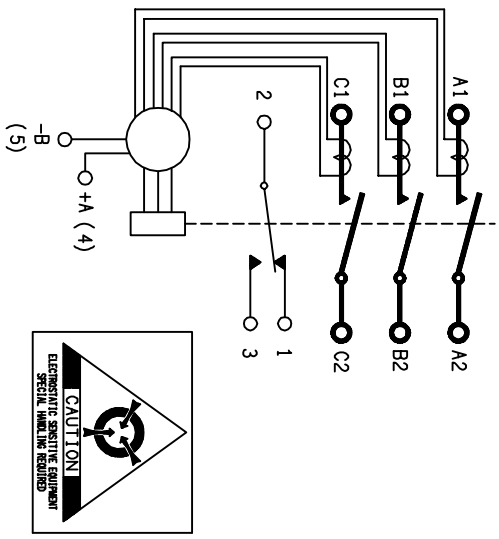

REV.	QTY	PART OR IDENTIFYING NO	NOMENCLATURE OR DESCRIPTION	FCSM NO	DRAWING OR SPECIFICATION	MATERIAL OR NOTE
17	1	39529-024	OVERLAY			
16	1	39529-009	OVERLAY			
15	1	39529-007	OVERLAY			
14	1	39529-001	OVERLAY			
13						
12	6	51807-034	WASHER - LOCK, NO. 1/4, SPLIT			BRONZE
11	2	51804-010	WASHER - LOCK, NO. 4, SPLIT			BRONZE
10	6	51703-064	WASHER - FLAT 1/2 X 17/64 X .032			BRASS
9	2	51204-960	SCREW 4-40 X 7/8 RD. HD.			BRASS
8	6	50407-074	NUT 1-4-28 X 3/8 X 3/16 HEX			BRASS
7	1	43154-050	CONTRACTOR ASSEMBLY - PRI.			
6	1	42726-001	SHIELD - TERMINAL			
5	1	42912-001	PLATE - BASE COVER			
4	1	41211-001	PLATE - WARNING			
3	1	42913-002	PLATE - WARNING DIAGRAM			
2	1	25695-001	PLATE - WARNING			
1	1	16043-001	PLATE - NAME			

GRUWMAN
GR835 AAU

UNLESS OTHERWISE SPECIFIED
DIMENSIONS ARE IN INCHES
TOLERANCES IN

2 PL. DEC. 3 PL. DEC. ANGLES
±.06 ±.010 ±1°

SCALE NONE SHEET

DR BY EAD 97/05/20
CHK BY RS 97/05/20
ENGR EAD 97/05/21
MFG JH 97/05/21

SIZE CODE IDENT
C 74063

DWG NO. RA-3100L

REF. TE P/N 1616133-4

Tyco Electronics
175 N. DIAMOND STREET WASHINGTON, OHIO 44002

REMOTE POWER CONTROLLER
115/208 VAC 3PST 50 AMP 093