

REVISIONS			
REV	DESCRIPTION, ECN, EAR NO.	DATE	APP'D
A	NEW PROPOSAL	APR14/22	L.CHAN

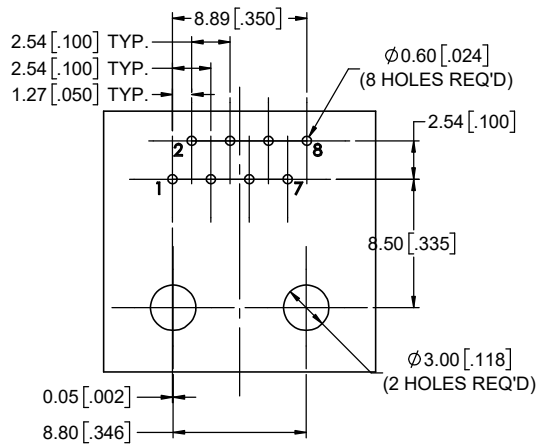
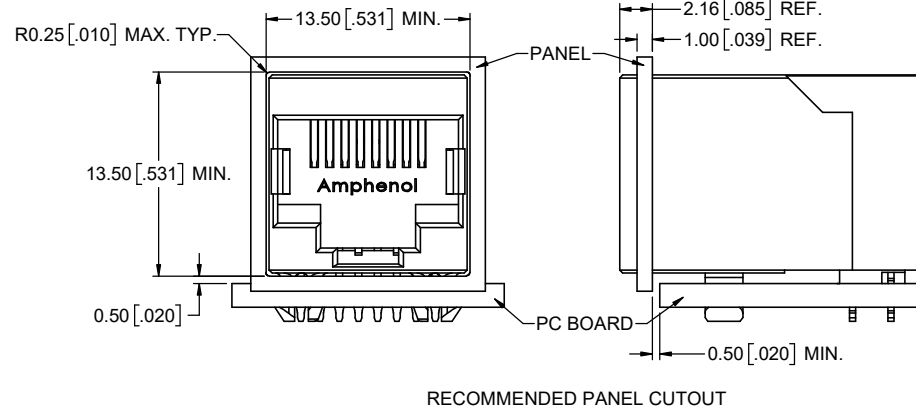
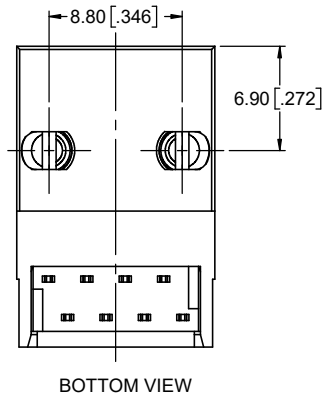
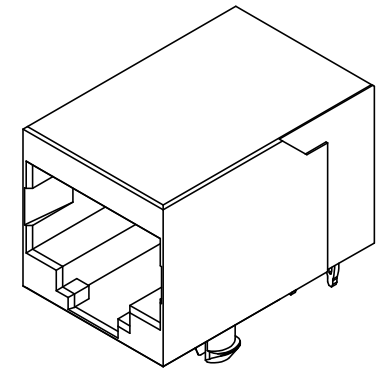

NOTES:

- MATERIALS:**
PLASTIC HOUSING: ENGINEERING THERMOPLASTIC FLAMMABILITY RATING UL94V-0,
COLOR: BLACK
CONTACT: PHOSPHOR BRONZE
PLATING: SELECTIVE GOLD PLATING ON MATING SURFACE
SEE AMPHENOL PART NUMBER FOR DETAIL,
100u" [2.54 MICRONS] MIN. MATTE TIN ON CONTACT TAILS
50u" [1.27 MICRONS] MIN. NICKEL UNDERPLATE.
 - THE REMOVAL FORCE OF PRESS FIT CONTACT SHOULD BE IN RANGE OF 10N PER PIN.
- AMPHENOL PART NUMBER: RJE56-188-0X10

- GOLD PLATING OPTIONS:
1 = 6u" GOLD PLATING
2 = 15u" GOLD PLATING
3 = 30u" GOLD PLATING
4 = 50u" GOLD PLATING



UNLESS SPECIFIED OTHERWISE	DRAWN	RONNIE.C	APR14/22
PRIMARY UNITS MILLIMETRES	CHECKED	KELVIN.T	APR14/22
SECONDARY INCHES	M.E. APP'D		
REFERENCE IN PARENTHESES	Q.A. APP'D		
GENERAL TOLERANCES	DWG APPR.		
1 DECIMAL PLACE ±0.38	ENG. REL. NO.		
2 DECIMAL PLACES ±0.25	REF.		
3 DECIMAL PLACES ±0.20	THIRD ANGLE PROJECTION		
ANGULAR DEGREES ±1.5°	DO NOT SCALE DRAWING		

Amphenol Canada Corp. Commercial Products	
SINGLE PORT MODULAR JACK, PRESS-FIT TYPE, 8 POSITION, 8 CONTACTS UNSHIELD, WITH GOLD PLATING OPTIONS -RoHS COMPLIANT	
DWG. NO.	REV
P-RJE56-188-0X10	A
CODE ID NO. 03554	DWG SIZE: X
SCALE: 4:1	SHEET 1 OF 1