



# SPECIFICATION FOR APPROVAL

CRYSTAL UNIT

## Features

Frequency range :

External dimensions (mm)

L : 3.2 x W : 1.5 x H : 0.8



## Electrical Characteristics

NO.	Parameters		Specifications	Notes
1	Nominal frequency	F0	32.768KHz	
2	Mode of Oscillation	-	Fundamental	AT-CUT
3	Load Capacitance	CL	6, 7, 9, 12.5pF	Or customizable
4	Frequency Tolerance	FL	±20ppm	Or customizable
5	Parabolic Coefficient	B	-0.034±0.006ppm/°C <sup>2</sup>	Or customizable
6	turnover temperature	Ti	25°C	
7	Operating Temperature	-	-40°C~+85°C	Or customizable
8	Maximum Drive Level	DL	1uW	
9	Recommended Drive Level	DL	0.1uW	
10	Effective Resistance	RR	70KΩ	Or customizable
11	Shunt Capacitance	C0	≤1.5pF	
12	Insulation Resistance	IR	≥500M Ω	at DC 100V
13	Aging	-	±3ppm	Or customizable
14	Storage Temperature Range	-	-55~+125°C	

★Note: If you need customization, please communicate with us.

## Ordering Information

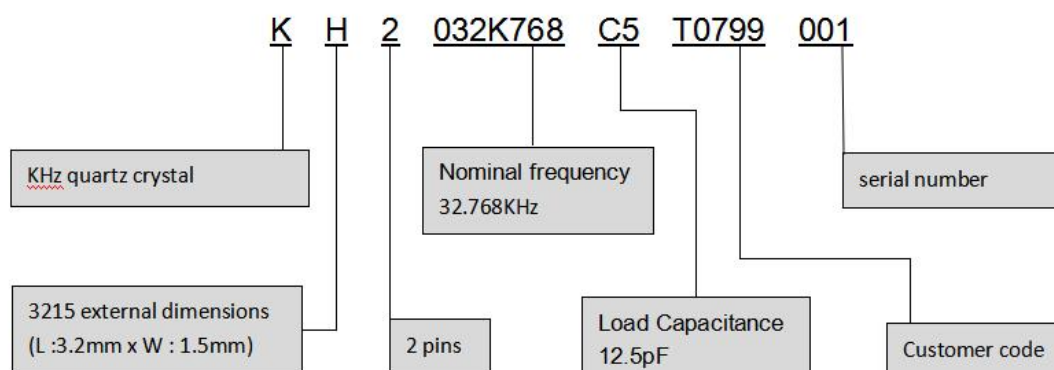

地址：安徽省合肥市经开区云谷路 2569 号

ADD: No. 2569 YunGu Road, HeFei Economy & Technology Development District

Mail : chehangyuan@hfjwt.cn

http: //www. hfjwt. cn



# SPECIFICATION FOR APPROVAL

CRYSTAL UNIT

## Dimensions

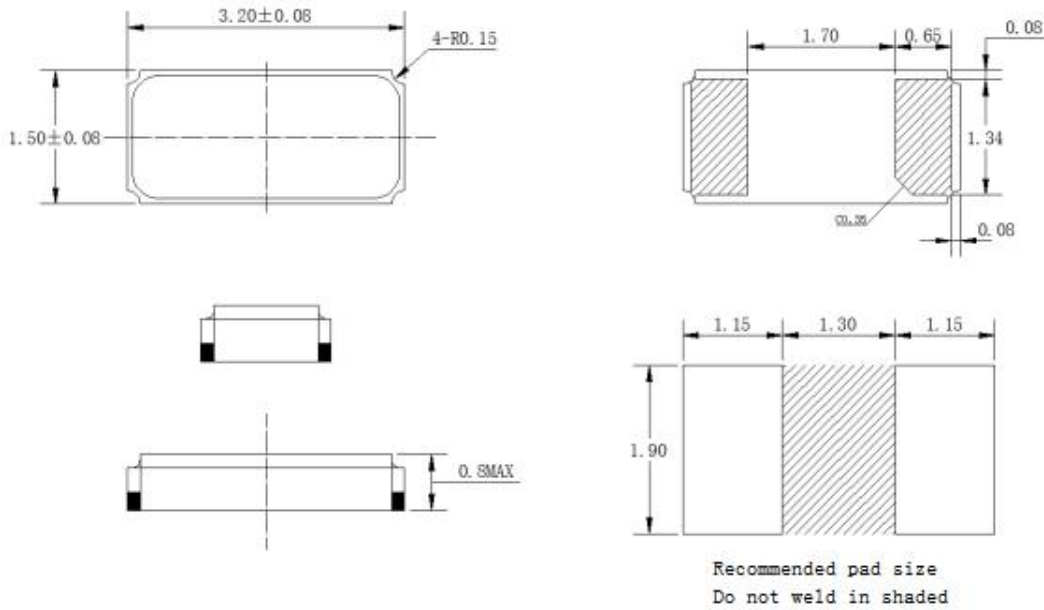

## Marking

JWTYYWWC※
-----------

JWT ----- Logo

YY ----- Year

WW ----- Week

C※ ----- Load Capacitance

Printing instructions: the combination of year and week is adopted for printing, such as 2212, which means the 12th week of 2022 production; ※ (6pF: 6, 7pF: 7, 9pF: 9, 12.5pf: C)

地址：安徽省合肥市经开区云谷路 2569 号

ADD: No. 2569 YunGu Road, HeFei Economy & Technology Development District

Mail: chehangyuan@hfjwt.cn

http: //www. hfjwt. cn



Reflow Profile

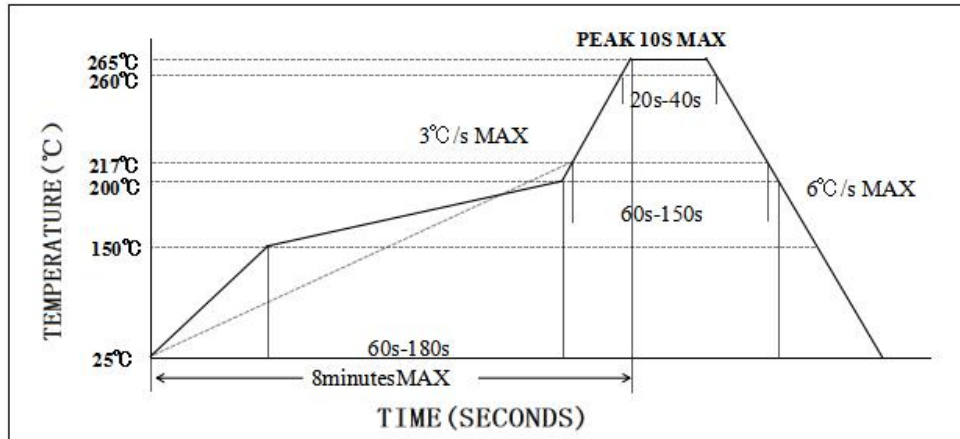

Reference standard: JEDEC J-STD-020. (lead free)

Dimension of taping and reel

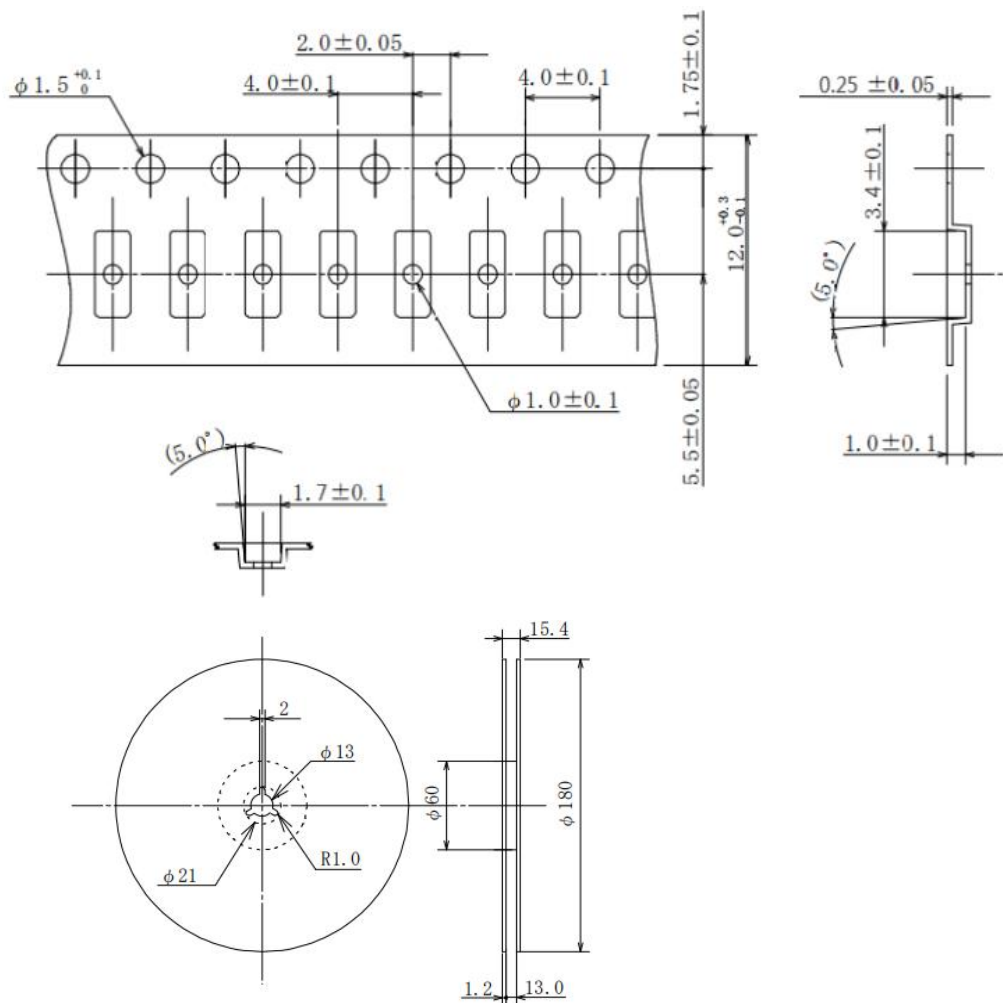

地址：安徽省合肥市经开区云谷路 2569 号

ADD: No. 2569 YunGu Road, HeFei Economy & Technology Development District

Mail: chehangyuan@hfjwt.cn

http: //www. hfjwt. cn