

10 9 8 7 6 5 4 3 2 1

PART NUMBER	CKT SIZE	DIM A	DIM B
87871-2317	17	20.0	23.5
87871-2319	19	22.5	26.0
87871-2321	21	25.0	28.5
87871-2323	23	27.5	31.0

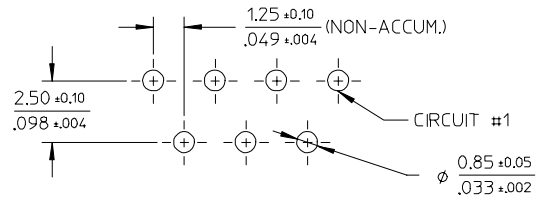

RECOMMENDED PCB LAYOUT
(BOARD THICKNESS : 1.6MM)

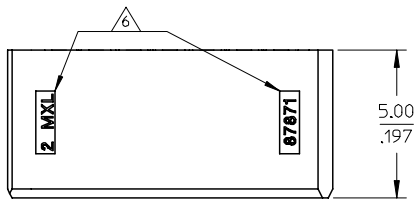
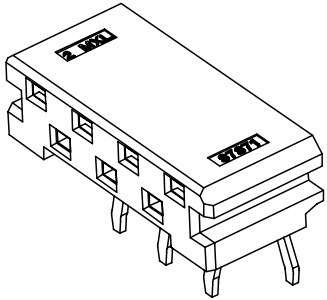
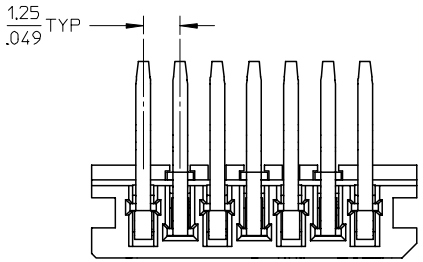
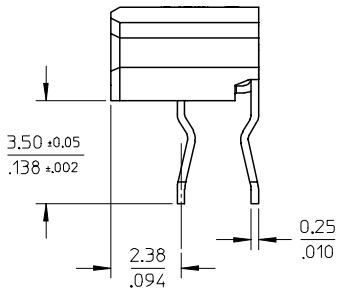
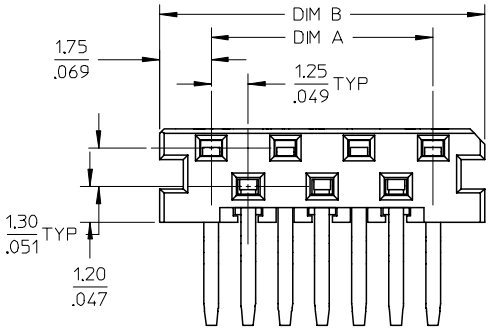

- NOTES
- MATERIAL : HOUSING - HIGH TEMP THERMOPLASTIC, GLASS FILLED, UL94 V-0, COLOR : NATURAL
TERMINAL - PHOSPHOR BRONZE
 - FINISHES : TERMINAL - TIN OVERALL
THICKNESS= 3 MICROMETER/118 MICROINCH MINIMUM
 - PRODUCT SPECIFICATION : PS-87871-006
 - PART MATEABLE TO 87872-11**
 - PARTS ARE PACKED IN TUBE.
△ CAVITY IDENTIFICATION NUMBER

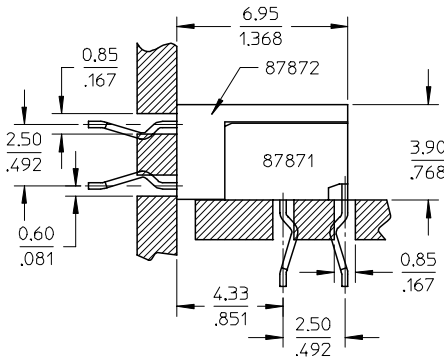

EC NO: S2005-0142 DRAWN: BLOW 2004/11/01 CHKD: PTLIM 2004/11/01 APPR: SKTOH 2004/11/04	QUALITY SYMBOLS ▽=0 ▽=0	GENERAL TOLERANCES (UNLESS SPECIFIED)		DIMENSION STYLE	SCALE	DESIGN UNITS	THIRD ANGLE PROJECTION	
				MM/IN	NTS	METRIC		
				mm	INCH	TITLE		SALES DRAWING ZIGZAG, 1.25MM, BTB RECEPTACLE (LEAD-FREE)
				ANGULAR ± 3 °		MOLEX MOLEX INCORPORATED		
A1	REV	DRAFT WHERE APPLICABLE MUST REMAIN WITHIN DIMENSIONS		DRAWN BY: BLOW DATE: 2004/03/31 CHECKED BY: PTLIM DATE: 2004/04/07 APPROVED BY: SCLOW DATE: 2004/04/13	DOCUMENT NO.: SD-87871-010 SHEET NO.: 1 OF 1			

9 8 7 6 5 4 3 2 1