

## MICROWAVE TUNING ELEMENTS

### METALLIC TUNING ELEMENTS



Metallic tuning elements have a metal tuning rotor inside a threaded mounting bushing. A thread on the rotor engages an internal thread in the bushing. The rotor

threads are slotted across their axis with 2 slots 180° apart. By compressing the probe along its axis, the slots function as a spring. The probe threads are pressed firmly into flank-to-flank engagement with the internal threads of the bushing, eliminating backlash, while providing a uniform adjustment torque that is self locking.

Standard models are useful from 2 to 33 GHz. Metallic tuning elements can be used to change the capacitive loading within a waveguide, or any place a metallic tuning probe is required.

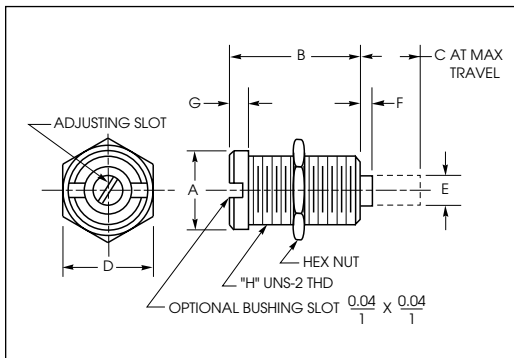

All dimensions are in /mm.  
Custom sizes available.

MODEL NO.	A	B	C	D	E	F	G	H
GRMB30301SN	0.135	0.120	0.030	0.156	0.072	0.002	0.035	0.120-80
	3.43	3.05	0.76	3.96	1.8	0.05	0.89	
GRMB30302SN	0.135	0.120	0.075	0.156	0.072	0.047	0.035	0.120-80
	3.43	3.05	1.9	3.96	1.8	1.2	0.89	
GRMB30602SN	0.135	0.240	0.075	0.156	0.072	0	0.035	0.120-80
	3.43	6.10	1.9	3.96	1.8	0	0.89	
GRMB30604SN	0.135	0.240	0.148	0.156	0.072	0	0.035	0.120-80
	3.43	6.10	3.76	3.96	1.8	0	0.89	
GRMB50301SN	0.210	0.125	0.023	0.220	0.125	0	0.037	0.190-64
	5.33	3.18	0.58	5.59	3.18	0	0.94	
GRMB50604SN	0.210	0.250	0.148	0.220	0.125	0	0.037	0.190-64
	5.33	6.35	3.76	5.59	3.18	0	0.94	
GRMB51411SN	0.210	0.552	0.450	0.220	0.125	0	0.042	0.190-64
	5.33	14.0	11.4	5.59	3.18	0	1.1	
GRMB70301SN	0.267	0.130	0.025	0.280	0.160	0	0.035	0.234-64
	6.78	3.30	0.64	7.11	4.06	0	0.89	
GRMB70403SN	0.267	0.187	0.106	0.280	0.160	0.023	0.031	0.234-64
	6.78	4.75	2.69	7.11	4.06	0.58	0.79	
GRMB70503SN	0.267	0.210	0.106	0.280	0.160	0	0.035	0.234-64
	6.78	5.33	2.69	7.11	4.06	0	0.89	
GRMB70505SN	0.267	0.210	0.180	0.280	0.160	0.074	0.035	0.234-64
	6.78	5.33	4.57	7.11	4.06	1.9	0.89	
GRMB70906SN	0.267	0.360	0.255	0.280	0.160	0	0.145	0.234-64
	6.78	9.14	6.48	7.11	4.06	0	3.68	
GRMB71109SN	0.267	0.450	0.345	0.280	0.160	0	0.240	0.234-64
	6.78	11.4	8.76	7.11	4.06	0	6.10	

#### Notes:

1. Gold plated brass bushings and chromated brass rotors in the sizes shown above are standard. Other sizes and/or materials are available, contact factory.
2. Hardware modifications:
  - 2.1 For slotted bushing, replace "S" in model number by "L".
  - 2.2 For ring nut (instead of hex nut), replace "N" in model number by "R".
  - 2.3 For no nut, replace "N" by "F".
3. Rotor adjusting slot is 0.060/1.5 x 0.016/0.41 for bushings where "H" is 0.120-80, 0.13/3.3 x 0.020/0.51 for bushings where "H" is 0.190-64, and 0.16/4.0 x 0.020/0.51 where "H" is 0.234-64.



**Sprague-Goodman Electronics, Inc.**

1700 SHAMES DRIVE, WESTBURY, NY 11590

TEL: 516-334-8700 • FAX: 516-334-8771

E-MAIL: info@spraguegoodman.com

### DIELECTRIC TUNING ELEMENTS



The use of a dielectric rod (instead of a metallic probe) for the tuning element will provide the lowest loss tuning for high frequency applications. When the dielectric rod is introduced into a microwave cavity it has the effect of making the cavity electrically larger, and lowering the resonant frequency. Dielectric tuning elements are excellent for adjusting the frequency of Gunn diode and IMPATT oscillators.

MODEL NO.	A	B	C	D	E	F	G	H
GRDA70913SN	0.267	0.629	0.280	0.359	0.525	0.152	0.215	0.234-64
	6.78	16.0	7.11	9.12	13.3	3.86	5.46	
GRDQ30604SN	0.135	0.260	0.160	0.240	0.168	0.062	0.205	0.120-80
	3.43	6.60	4.06	6.10	4.27	1.6	5.21	
GRDS30604SN	0.135	0.260	0.160	0.240	0.168	0.062	0.205	0.120-80
	3.43	6.60	4.06	6.10	4.27	1.6	5.21	
GRDS70503SN	0.267	0.219	0.280	0.210	0.115	0.152	0.175	0.234-64
	6.78	5.56	7.11	5.33	2.92	3.86	4.45	
GRDS70907SN	0.267	0.369	0.280	0.359	0.265	0.152	0.215	0.234-64
	6.78	9.37	7.11	9.12	6.73	3.86	5.46	

Note: For hardware modifications and adjusting slot sizes see notes on page 1.

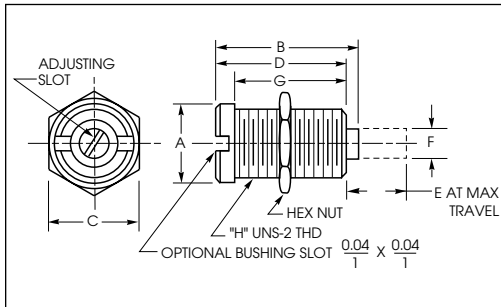

All dimensions are in /mm.  
Custom sizes available.

### TUNING ROTORS



Metallic and dielectric tuning rotors are available for applications in which the user wishes to provide threads in his structure (instead of using a bushing).

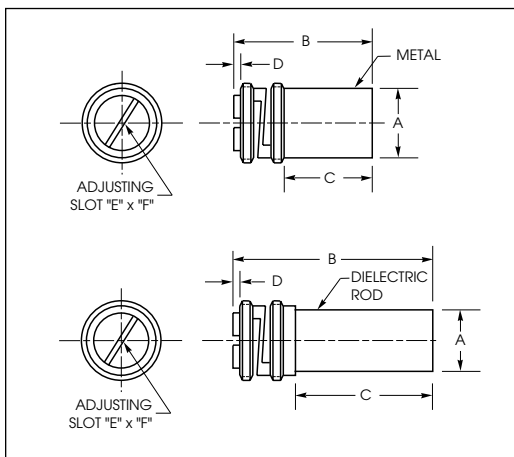

All dimensions are in /mm.  
Custom sizes available.

MODEL NO.	A	B	C	D	E	F	ROD MATERIAL	THREAD-2A
GREA21712	0.062	0.674	0.490	0.020	0.016	0.060	Alumina	0.94-80UNS
	1.6	17.1	12.4	0.51	0.41	1.5		
GREA41108	0.152	0.430	0.300	0.010	0.020	0.145	Alumina	0.190-64UNS
	3.86	10.9	7.62	0.25	0.51	3.68		
GREA41209	0.152	0.475	0.345	0.010	0.020	0.145	Alumina	0.190-64UNS
	3.86	12.1	8.76	0.25	0.51	3.68		
GREA41613	0.152	0.625	0.495	0.010	0.020	0.145	Alumina	0.190-64UNS
	3.86	15.9	12.6	0.25	0.51	3.68		
GREA42319	0.152	0.884	0.750	0.010	0.020	0.145	Alumina	0.190-64UNS
	3.86	22.5	19.1	0.25	0.51	3.68		
GREB11310	0.040	0.500	0.385	0.020	0.016	0.040	Brass	0.060-80UNF
	1.0	12.7	9.78	0.51	0.41	1.0		
GREB20301	0.072	0.122	0.030	0.020	0.016	0.060	Brass	0.094-80UNS
	1.8	3.10	0.76	0.51	0.41	1.5		
GREB20402	0.072	0.165	0.075	0.020	0.016	0.060	Brass	0.094-80UNS
	1.8	4.19	1.9	0.51	0.41	1.5		
GREB20503	0.060	0.215	0.100	0.020	0.016	0.060	Brass	0.086-56UNC
	1.5	5.46	2.54	0.51	0.41	1.5		
GREB20603	0.072	0.215	0.125	0.020	0.016	0.060	Brass	0.094-80UNS
	1.8	5.46	3.18	0.51	0.41	1.5		
GREB20604	0.072	0.237	0.147	0.020	0.016	0.060	Brass	0.094-80UNS
	1.8	6.02	3.73	0.51	0.41	1.5		
GREB30604	0.125	0.250	0.148	0.010	0.020	0.120	Brass	0.156-64UNS
	3.18	6.35	3.76	0.25	0.51	3.05		
GREB41411	0.160	0.554	0.450	0.010	0.020	0.145	Brass	0.190-64UNS
	4.06	14.1	11.4	0.25	0.51	3.68		
GREB90904	0.345	0.370	0.150	0.030	0.060	0.320	Brass	0.375-64UNS
	8.76	9.40	3.81	0.76	1.52	8.13		
GREQ81709	0.320	0.652	0.372	0.030	0.060	0.320	Quartz	0.375-64UNS
	8.13	16.6	9.45	0.76	1.52	8.13		
GRES20805	0.062	0.300	0.178	0.020	0.016	0.060	Sapphire	0.094-80UNS
	1.6	7.62	4.52	0.51	0.41	1.5		

## DIELECTRIC RESONATOR TUNERS



Specifically designed for tuning dielectric resonator oscillators and filters, the rotor of these

devices varies the distance between a tuning disk or rod of various materials and a dielectric resonator "puck". Standard models are compatible with a wide variety of puck diameters and mounting configurations, and operate in the frequency range of 2 to 18 GHz.

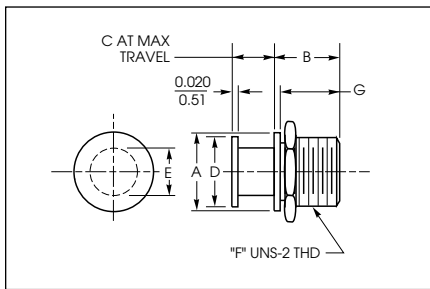

All dimensions are in /mm.  
Custom sizes available.

**Notes:**

1. Gold plated brass bushings and chromated brass rotors in the sizes shown above are standard. Other sizes and/or materials are available, contact factory.
2. Hardware modifications:
  - 2.1 For 0.04/1 x 0.04/1 slotted bushing, substitute "L" for "S" in model number.
  - 2.2 For ring nut (instead of hex nut), replace "N" in model number by "R".
  - 2.3 For no nut, replace "N" by "F".
  - 2.4 To add seal cap, add "C" at the end of the model number for a seal cap without a slot, and "B" for a seal cap with a screw driver slot.
3. Rotor adjusting slot is 0.16/4.0 x 0.020/0.51.

MODEL NO.	A	B	C	D	E	F	G
GRRB70504SN04	0.267	0.210	0.16	0.16	0.16	0.234-64	0.175
	6.78	5.33	4.1	4.1	4.1		4.45
GRRB70504SN05	0.267	0.210	0.16	0.20	0.16	0.234-64	0.175
	6.78	5.33	4.1	5.1	4.1		4.45
GRRB70504SN06	0.267	0.210	0.16	0.25	0.16	0.234-64	0.175
	6.78	5.33	4.1	6.4	4.1		4.45
GRRB70504SN08	0.267	0.210	0.16	0.30	0.16	0.234-64	0.175
	6.78	5.33	4.1	7.6	4.1		4.45
GRRB70504SN09	0.267	0.210	0.16	0.35	0.16	0.234-64	0.175
	6.78	5.33	4.1	8.9	4.1		4.45
GRRB70504SN10	0.267	0.210	0.16	0.40	0.16	0.234-64	0.175
	6.78	5.33	4.1	10	4.1		4.45
GRRB70504SN11	0.267	0.210	0.16	0.45	0.16	0.234-64	0.175
	6.78	5.33	4.1	11	4.1		4.45
GRRB70504SN13	0.267	0.210	0.16	0.50	0.16	0.234-64	0.175
	6.78	5.33	4.1	13	4.1		4.45
GRRB70904SN04	0.267	0.360	0.16	0.16	0.16	0.234-64	0.215
	6.78	9.14	4.1	4.1	4.1		5.46
GRRB70904SN05	0.267	0.360	0.16	0.20	0.16	0.234-64	0.215
	6.78	9.14	4.1	5.1	4.1		5.46
GRRB70904SN06	0.267	0.360	0.16	0.25	0.16	0.234-64	0.215
	6.78	9.14	4.1	6.4	4.1		5.46
GRRB70904SN08	0.267	0.360	0.16	0.30	0.16	0.234-64	0.215
	6.78	9.14	4.1	7.6	4.1		5.46
GRRB70904SN09	0.267	0.360	0.16	0.35	0.16	0.234-64	0.215
	6.78	9.14	4.1	8.9	4.1		5.46
GRRB70904SN10	0.267	0.360	0.16	0.40	0.16	0.234-64	0.215
	6.78	9.14	4.1	10	4.1		5.46
GRRB70904SN11	0.267	0.360	0.16	0.45	0.16	0.234-64	0.215
	6.78	9.14	4.1	11	4.1		5.46
GRRB70904SN13	0.267	0.360	0.16	0.50	0.16	0.234-64	0.215
	6.78	9.14	4.1	13	4.1		5.46
GRRB71104SN04	0.267	0.450	0.16	0.16	0.16	0.234-64	0.210
	6.78	11.4	4.1	4.1	4.1		5.33
GRRB71104SN05	0.267	0.450	0.16	0.20	0.16	0.234-64	0.210
	6.78	11.4	4.1	5.1	4.1		5.33
GRRB71104SN06	0.267	0.450	0.16	0.25	0.16	0.234-64	0.210
	6.78	11.4	4.1	6.4	4.1		5.33
GRRB71104SN08	0.267	0.450	0.16	0.30	0.16	0.234-64	0.210
	6.78	11.4	4.1	7.6	4.1		5.33
GRRB71104SN09	0.267	0.450	0.16	0.35	0.16	0.234-64	0.210
	6.78	11.4	4.1	8.9	4.1		5.33
GRRB71104SN10	0.267	0.450	0.16	0.40	0.16	0.234-64	0.210
	6.78	11.4	4.1	10	4.1		5.33
GRRB71104SN11	0.267	0.450	0.16	0.45	0.16	0.234-64	0.210
	6.78	11.4	4.1	11	4.1		5.33
GRRB71104SN13	0.267	0.450	0.16	0.50	0.16	0.234-64	0.210
	6.78	11.4	4.1	13	4.1		5.33

### LC TUNING ELEMENTS



Variations of the standard metallic units, LC tuning elements are designed specifically for filter applications. These devices provide a fixed post length which is

extended by rotating the metallic rotor. A typical application is a direct-coupled TEM mode coaxial configuration. The post length is selected to cover the desired range. A circuit is designed around the tunable post so that each section approximates 76 ohms for optimum resonator Q and high selectivity.

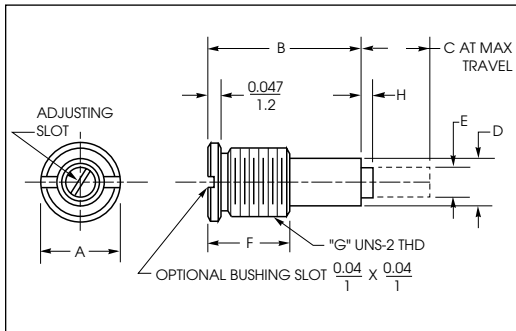

All dimensions are in /mm.  
Custom sizes available.

MODEL NO.	A	B	C	D	E	F	G	H
GRFB50503SF	0.187	0.195	0.108	0.102	0.072	0.152	0.156-64	0.005
	4.75	4.95	2.74	3.05	1.8	3.86		0.1
GRFB50904SF	0.187	0.355	0.148	0.120	0.072	0.232	0.156-64	0
	4.75	9.02	3.76	3.05	1.8	5.89		0
GRFB51204SF	0.187	0.482	0.148	0.120	0.072	0.232	0.156-64	0
	4.75	12.2	3.76	3.05	1.8	5.89		0
GRFB51504SF	0.187	0.602	0.148	0.120	0.072	0.152	0.156-64	0
	4.75	15.3	3.76	3.05	1.8	3.86		0
GRFB71411SF	0.265	0.557	0.450	0.170	0.125	0.232	0.234-64	0
	6.73	14.1	11.4	4.32	3.18	5.89		0
GRFB71806SF	0.281	0.700	0.250	0.210	0.160	0.232	0.250-64	0
	7.14	17.8	6.35	5.33	4.06	5.89		0
GRFB72211SF	0.265	0.882	0.450	0.170	0.125	0.232	0.234-64	0
	6.73	22.4	11.4	4.32	3.18	5.89		0
GRFB72506SF	0.281	1.000	0.250	0.210	0.160	0.232	0.250-64	0
	7.14	25.40	6.35	5.33	4.06	5.89		0
GRFB73109SF	0.281	1.232	0.346	0.210	0.160	0.232	0.250-64	0
	7.14	31.3	8.79	5.33	4.06	5.89		0
GRFB74009SF	0.281	1.582	0.346	0.210	0.160	0.232	0.250-64	0
	7.14	40.18	8.79	5.33	4.06	5.89		0

**Notes:**

1. For slotted bushing, replace "S" in model number by "L".
2. To include a mating nut on the bushing, replace final "F" in the model number by "N" for a hex nut, or by "R" for a ring nut.

### RESISTIVE TUNING ELEMENTS



The use of a lossy rod material for the rotor of the tuning element provides a convenient and effective means of trimming the microwave device in a waveguide or cavity. The amount of power absorbed is a function of the depth of insertion of the rod into the waveguide or cavity. Standard models are ideal for frequencies of 1 to 18 GHz.

The amount of power absorbed is a function of the depth of insertion of the rod into the waveguide or cavity. Standard models are ideal for frequencies of 1 to 18 GHz.

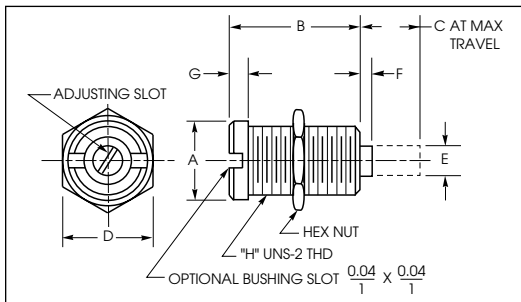

All dimensions are in /mm.  
Custom sizes available.

MODEL NO.	A	B	C	D	E	F	G	H
GRLE30603SN	0.135	0.240	0.130	0.160	0.078	0	0.035	0.120-80
	3.43	6.10	3.30	4.06	2.0	0	0.89	
GRLE30604SN	0.135	0.240	0.168	0.160	0.062	0.020	0.035	0.120-80
	3.43	6.10	4.27	4.06	1.6	0.51	0.89	
GRLE70906SN	0.267	0.359	0.250	0.280	0.152	0	0.144	0.234-64
	6.78	9.12	6.35	7.11	3.86	0	3.66	

**Note:** For hardware modifications and adjusting slot sizes see notes on page 1.