

THIS DRAWING IS UNPUBLISHED. VERTRÄULICHE UNVERÖFFENTLICHTE ZEICHNUNG. RELEASED FOR PUBLICATION FREI FÜR VERÖFFENTLICHUNG. 2014 - ALL RIGHTS RESERVED. ALLE RECHTE VORBEHALTEN. MATED WITH: PASSEND ZU: -

PROJECT NR.: EGATN02042

REVISIONS		ÄNDERUNGEN			
P	LTR	DESCRIPTION	DATE	DWN	APVD
A1		PART NO. 2-1563229-2/-3 ADDED	24SEP2014	RM	JRY
A2		NOTE 7 CHANGED. NOTE 8 ADDED	01DEC2014	RM	HJA
A3		VIEWED PCB POSITION CORRECTED	20JAN2016	ST	PNI

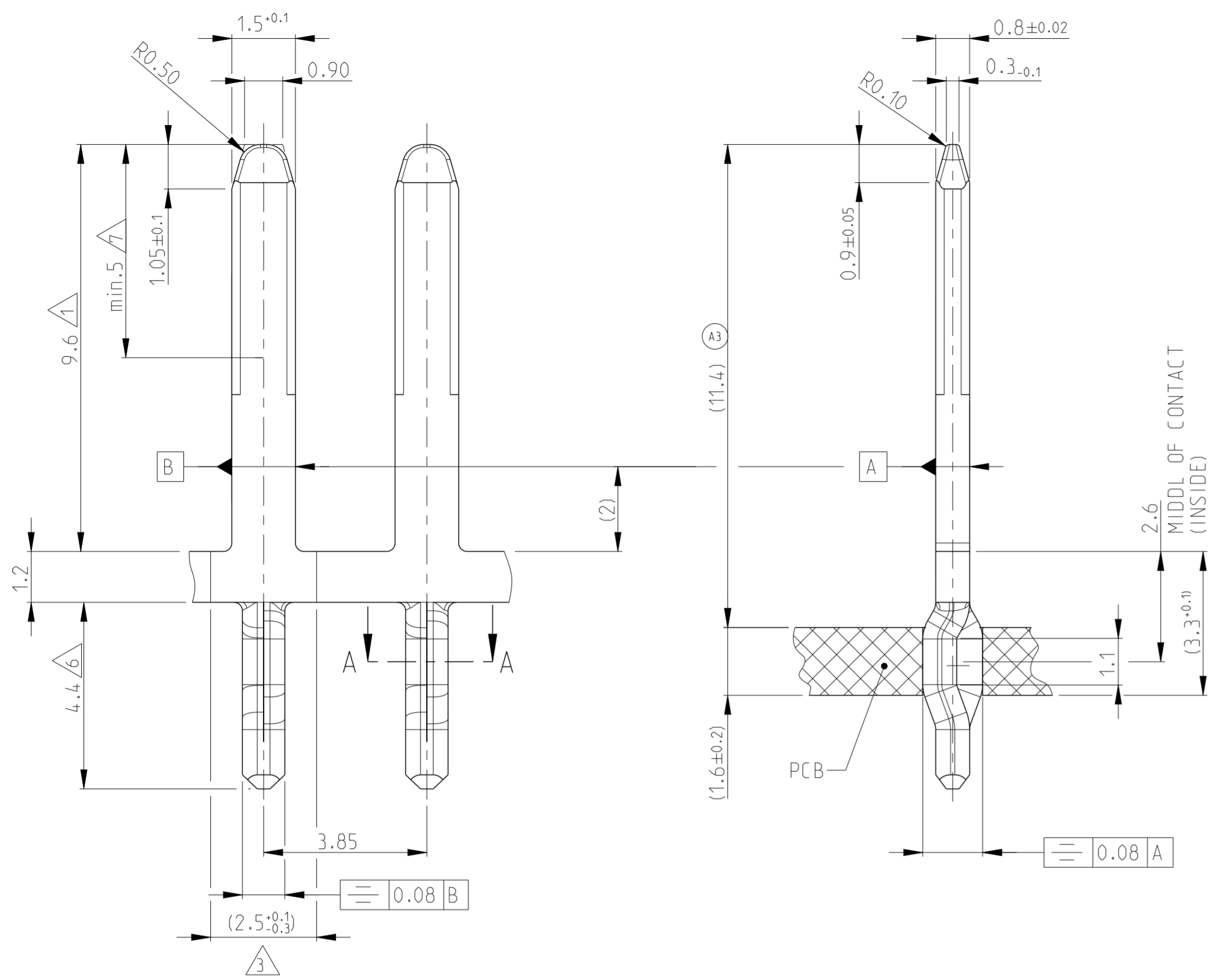

A-A  
20:1

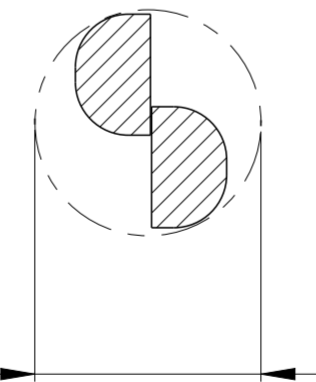

NOTES:  
BEMERKUNGEN:

- 1 2 μm-4 μm Sn OVER 1.2 μm-2.7 μm Ni  
2 μm-4 μm Sn UEBER 1.2 μm-2.7 μm Ni

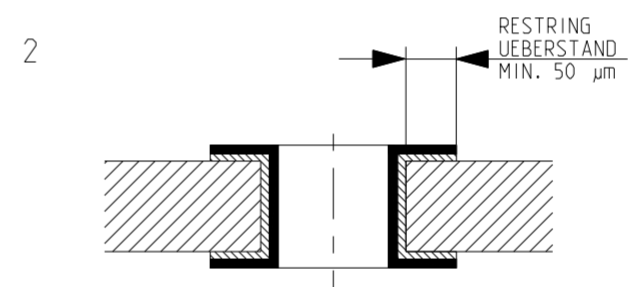

PLATED THROUGH HOLE SPECIFICATION		SPEZIFIKATION FUER DURCHPLATIERTE BOHRUNGEN			
Cu THICKNESS	KUPFER-SCHICHTDICKE	25-50 μm			
Sn THICKNESS	ZINN-SCHICHTDICKE	4-15 μm			
DRILLED HOLE	BOHRLOCH-Ø	1.5±0.025	FINISHED HOLE	PLATIRTER LOCH-Ø	1.29 <sup>+0.15</sup>

- 2
- 3 DIMENSION OF LOOSE PIECE MASS FUER EINZELTEIL
- 4 TO BE REELED ON PANCAKE REEL WITH INTERLEAVING PAPER PAPPSPULEN MIT ZWISCHENLAGENPAPIER
- 5 TO BE REELED ON PLASTIC REEL WITH INTERLEAVING PAPER KUNSTSTOFFSPULEN MIT ZWISCHENLAGENPAPIER
- 6 0.8 μm-1.8 μm Sn OVER 1.2 μm-2.7 μm Ni (ACTION PIN AREA)  
0.8 μm-1.8 μm Sn UEBER 1.2 μm-2.7 μm Ni (ACTION-PIN-BEREICH)
- 7 MIN. 0.8 μm Au OVER 1.0 μm-2.2 μm Ni  
MIN. 0.8 μm Au UEBER 1.0 μm-2.2 μm Ni
- 8 MAX. TWO LOOSE SPLICES PER REEL  
MAX. ZWEI LOSE TRENNSTELLEN PRO SPULE

DIRECTION OFF TOP OF REEL

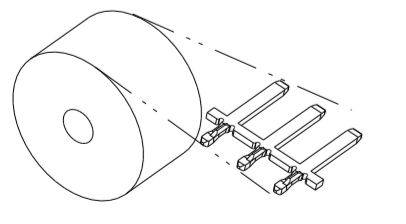

1-	-2
1-	-3
2-	-2
2-	-3

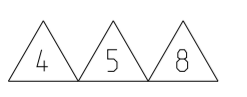

TE PART NO.	REV.	MATERIAL	SURFACE	REEL PACKING
2-1563229-3	A	CuSn 4	6 + 7	5 8
2-1563229-2	A	CuSn 4	6 + 7	4 8
1-1563229-3	A	CuSn 4	1 + 6	5 8
1-1563229-2	A	CuSn 4	1 + 6	4 8

DIMENSIONS: MASSENHEITEN: (mm)		TOLERANCES UNLESS OTHERWISE SPECIFIED: ALLGEMEINTOLERANZEN	
0-PLC	±	0-PLC	±0.2
1-PLC	±0.2	2-PLC	±0.1
2-PLC	±	3-PLC	±
3-PLC	±	4-PLC	±
4-PLC	±	ANGLES / WINKEL	±
		FINISH / OBERFLAECHE / FARBE	

DWN	31AUG2007	H.-J. Arnold	
CHK	31AUG2007	J. Ryll	
APVD	-	-	
NAME	TE Connectivity		
PRODUCT SPEC	108-18867		
APPLICATION SPEC	114-18570		
WEIGHT	0.14 g	SCALE	10:1
Customer Drawing	/KUNDENZEICHNUNG	SHEET	1 OF VON 1
REV	A3	RESTRICTED TO NUR FUER	