

THIS DRAWING IS UNPUBLISHED. RELEASED FOR PUBLICATION
 © COPYRIGHT - By - ALL RIGHTS RESERVED.

REVISIONS				
P	LTR	DESCRIPTION	DATE	APVD
F1		REDRAWN PER ECO-16-010549	12OCT2016	RS DR

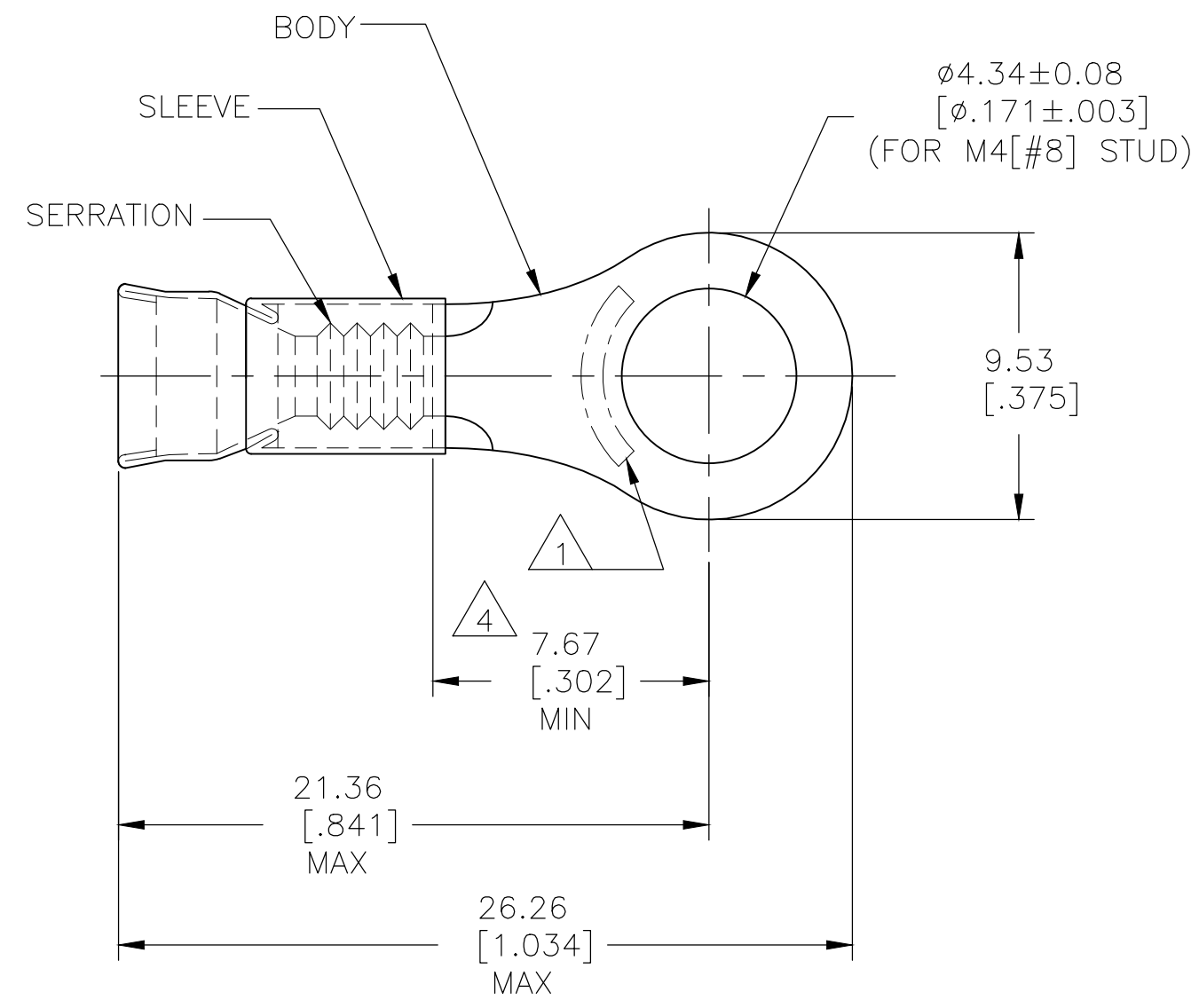

- 1 STAMP AMP 12-10* APPROX AS SHOWN.
- 2 WIRE INSUL DIA: 3.81-5.84 [.150-.230].
- 3 TONGUE MATL THK: 1.02±0.05 [.040±.002].
- 4 DIMENSION APPLIES FROM EDGE OF METAL WIRE BARREL TO CENTER OF STUD HOLE.

PRELIMINARY	2500	TAPE & REEL	323067-2
	500	LOOSE PIECE	323067
	QTY	PACKAGE TYPE	PART NO

AMP INCORPORATED CUSTOMER SERVICE SYSTEM		MAX RECOMMENDED OPERATING TEMPERATURE: 343°C[650°F]	THIS DRAWING IS A CONTROLLED DOCUMENT.		DWN L OLMEDA 10OCT94	TE Connectivity			
FOR ADDITIONAL PRODUCT INFORMATION OR COPIES OF DRAWINGS AND TECHNICAL DOCUMENTS	PRODUCT INFORMATION CENTER 1-800-522-6752	VOLTAGE RATING: -	DIMENSIONS: mm [INCHES]	TOLERANCES UNLESS OTHERWISE SPECIFIED:	CHK M ELLIS 10OCT94				
FOR APPLICATION TOOLING INFORMATION	TOOLING ASSISTANCE CENTER 1-800-722-1111	CIRCULAR MIL AREA: 2.62-6.64mm²[5,180-13,100]			APVD S BORTNER 10OCT94	TERMINAL, RING TONGUE, STRATO-THERM™, DIAMOND GRIP™ WIRE SIZE, 12-10 AWG			
FOR ORDER ENTRY	1-800-526-5142	STRAINED WIRE	MATERIAL BODY, CU PER ASTM B152 SLEEVE, NI SIL PER ASTM B122	FINISH BODY, NP, SAE AMS QQ-N-290	PRODUCT SPEC -	SIZE A3	CAGE CODE 00779	DRAWING NO C-323067	RESTRICTED TO -
CUSTOMER DRAWING					WEIGHT	SCALE 4:1		SHEET 1 OF 1	REV F1