

EJECTION LATCHES OMITTED IN THIS VIEW FOR CLARITY

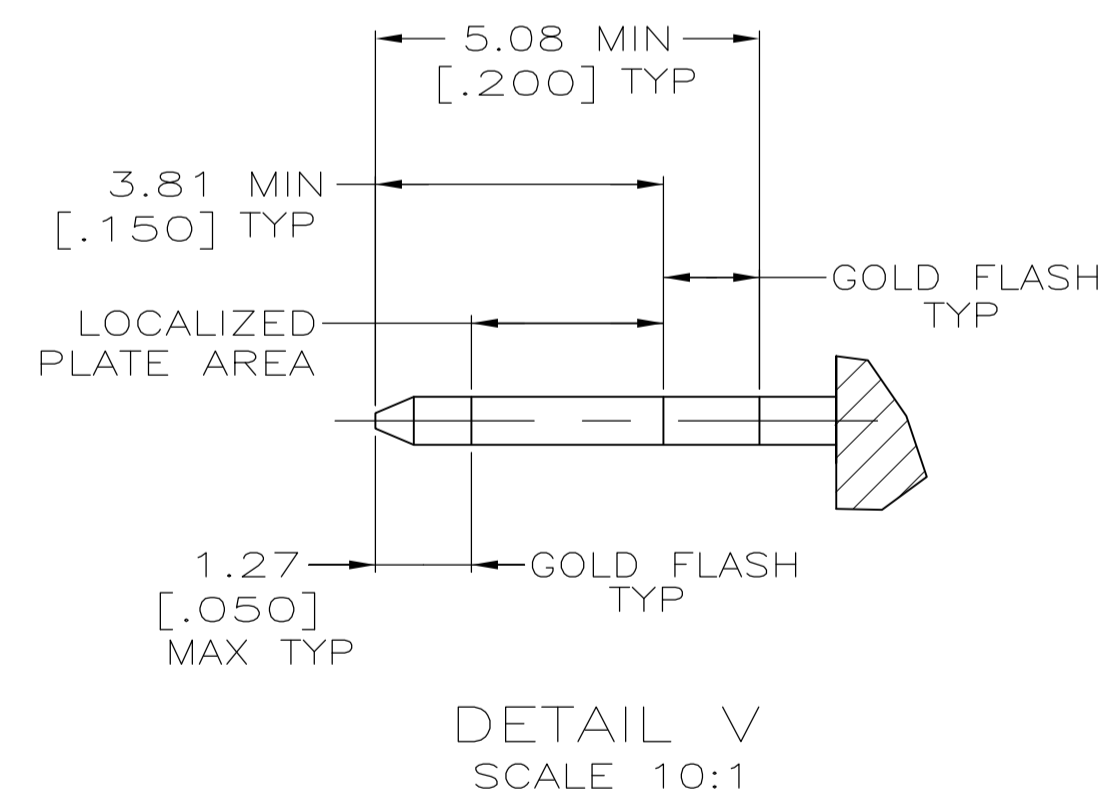

- 1 COORDINATE DIMENSION APPLIES FROM BASIC LOCATION.
- 2 10 AND 14 POSITION SIZES CONTAIN ONLY ONE SLOT FOR SNAP-IN POLARIZER (MILITARY POLARIZATION) LOCATED AS SHOWN.
- 3 10 POSITION SIZES CONTAIN ONLY ONE SLOT FOR DUAL POLARIZATION, LOCATED AS SHOWN.
- 4 RECOMMENDED PRINTED CIRCUIT BOARD THICKNESS IS 3.18 [125].
- 5 DISTANCE REQUIRED BY EJECTION LATCHES IN THE OPEN POSITION.
- 6 MATERIAL HOUSING & LATCHES: GLASS FILLED NYLON OR POLYESTER, UL94V-0 RATED, BLACK. POSTS: PHOS BRONZE OR BRASS.
- 7 POSTS: GOLD FLASH OVER PALLADIUM-NICKEL PLATE, 0.38µm[.00015] MIN TOTAL ON THE LOCALIZED PLATE AREA, 2.54µm [0.000100] MIN TIN PLATE ON THE SOLDER-TAILS, 1.27µm[.000050] MIN NICKEL UNDERPLATE ON THE ENTIRE POST. -OR- 0.38µm[.000015] MIN GOLD PLATE ON THE LOCALIZED PLATE AREA, 2.54µm[.000100] MIN TIN PLATE ON THE SOLDER-TAILS, 1.27µm[.000050] MIN NICKEL UNDERPLATE ON THE ENTIRE POST.
- 8 DATUMS -M- & -N- TO BE ESTABLISHED BY CUSTOMER.

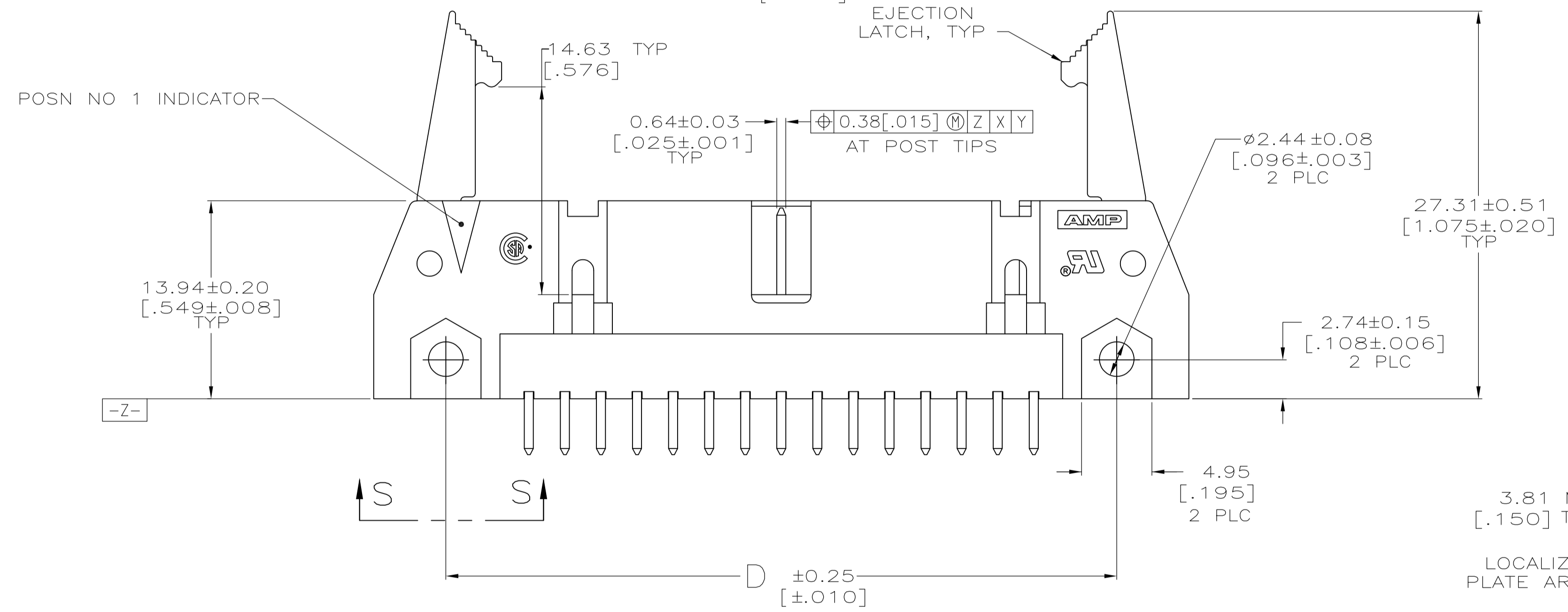
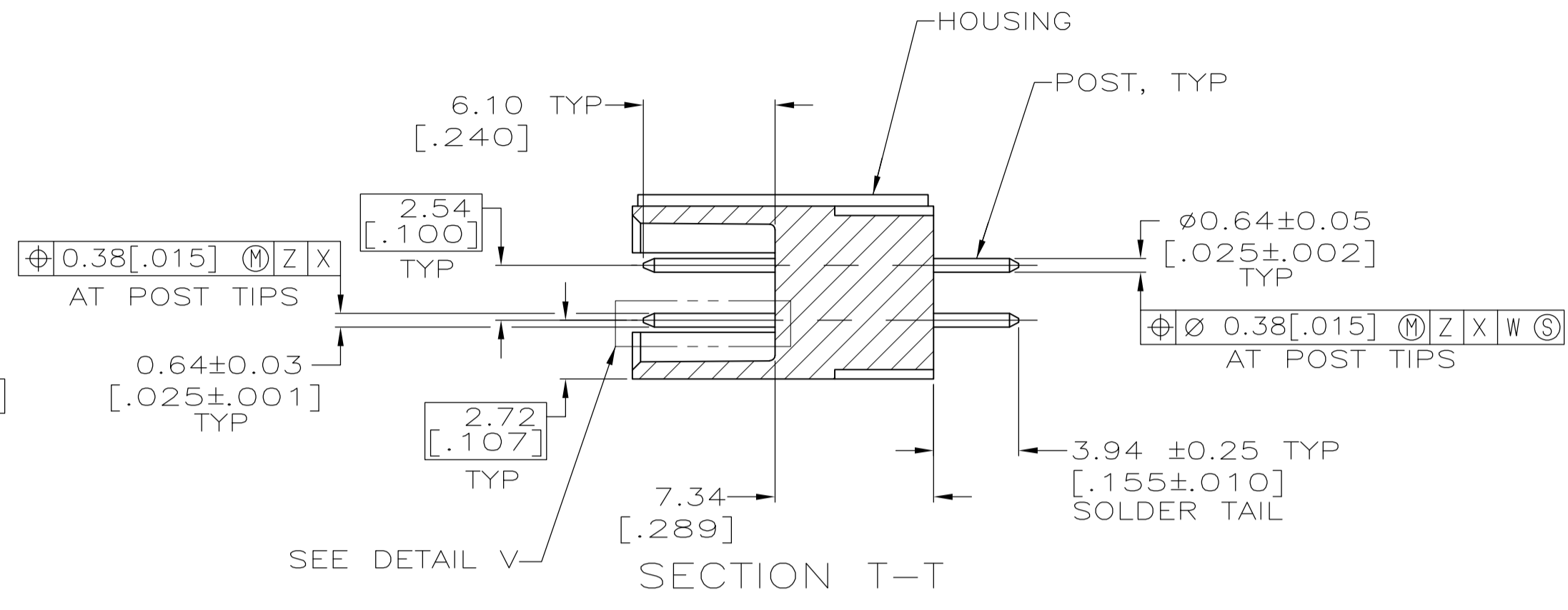
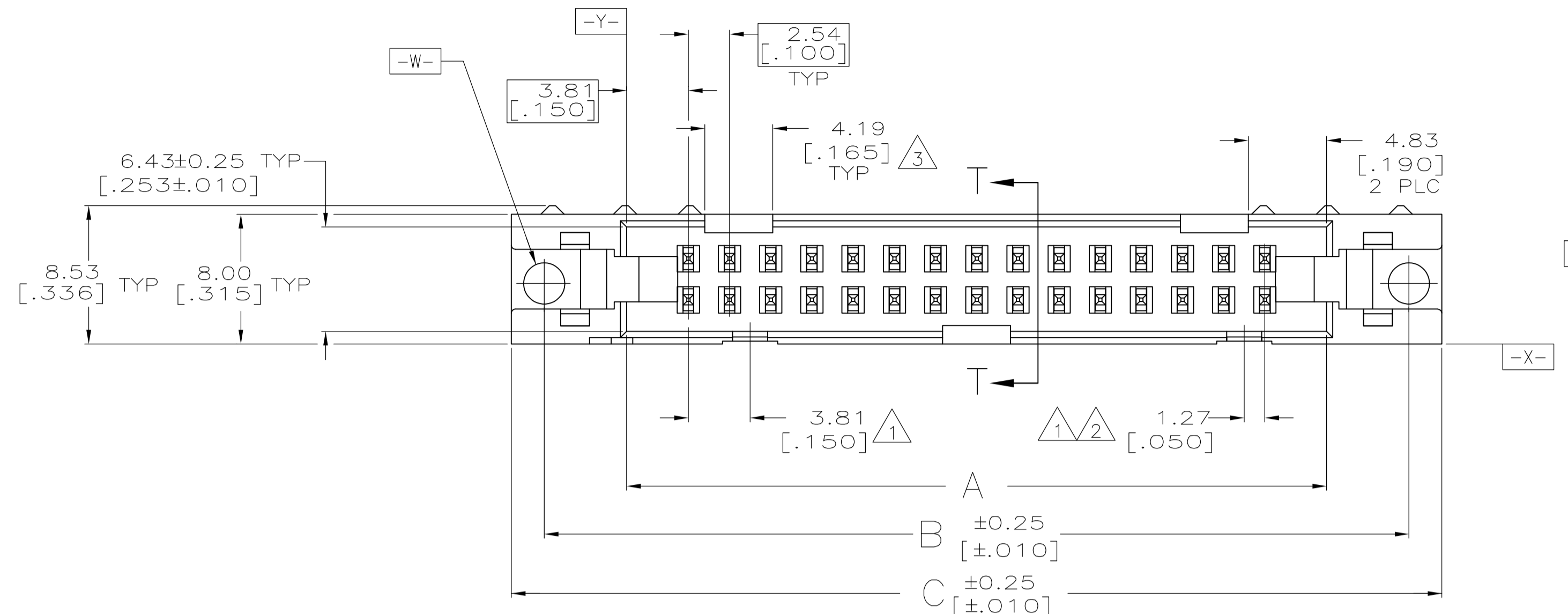
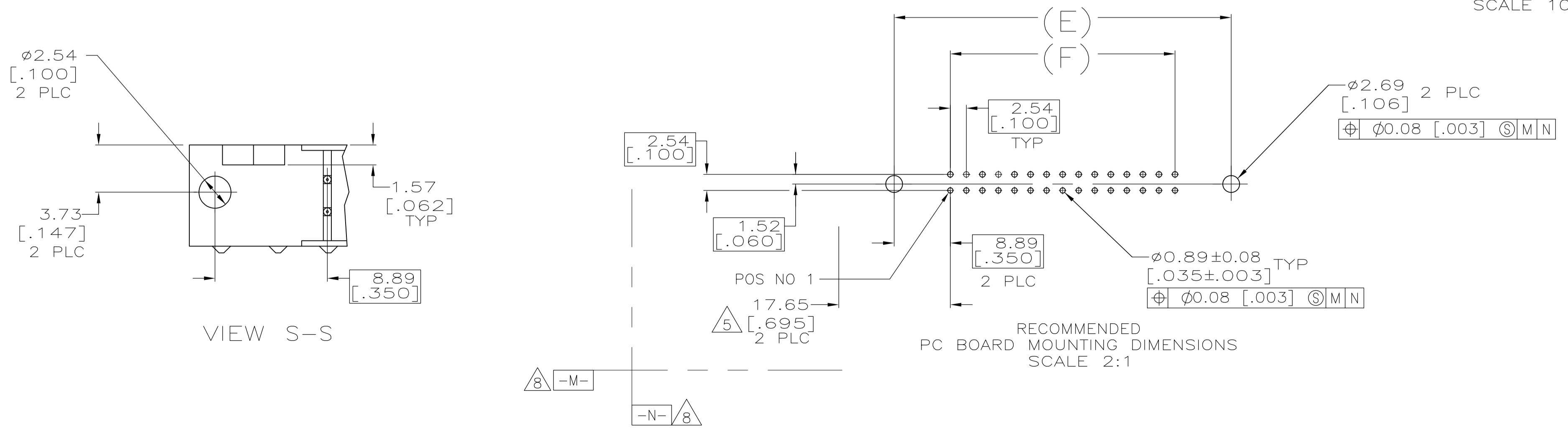

78.74	96.52	90.42	100.58	96.52	86.36	64	1-5499923-2
[3.100]	[3.800]	[3.560]	[3.960]	[3.800]	[3.400]		
73.66	91.44	85.34	95.50	91.44	81.28	60	1-5499923-1
[2.900]	[3.600]	[3.360]	[3.760]	[3.600]	[3.200]		
60.96	78.74	72.64	82.80	78.74	68.58	50	1-5499923-0
[2.400]	[3.100]	[2.860]	[3.260]	[3.100]	[2.700]		
48.26	66.04	59.94	70.10	66.04	55.88	40	5499923-9
[1.900]	[2.600]	[2.360]	[2.760]	[2.600]	[2.200]		
40.64	58.42	52.32	62.48	58.42	48.26	34	5499923-8
[1.600]	[2.300]	[2.060]	[2.460]	[2.300]	[1.900]		
35.56	53.34	47.24	57.40	53.34	43.18	30	5499923-7
[1.400]	[2.100]	[1.860]	[2.260]	[2.100]	[1.700]		
30.48	48.26	42.16	52.32	48.26	38.10	26	5499923-6
[1.200]	[1.900]	[1.660]	[2.060]	[1.900]	[1.500]		
27.94	45.72	39.62	49.78	45.72	35.56	24	5499923-5
[1.100]	[1.800]	[1.560]	[1.960]	[1.800]	[1.400]		
22.86	40.64	34.54	44.70	40.64	30.48	20	5499923-4
[.900]	[1.600]	[1.360]	[1.760]	[1.600]	[1.200]		
17.78	35.56	29.46	39.62	35.56	25.40	16	5499923-3
[.700]	[1.400]	[1.160]	[1.560]	[1.400]	[1.000]		
OBSOLETE	15.24	33.02	26.92	37.08	33.02	14	5499923-2
	[.600]	[1.300]	[1.060]	[1.460]	[1.300]		
	10.16	27.94	21.84	32.00	27.94	10	5499923-1
	[.400]	[1.100]	[.860]	[1.260]	[1.100]		
	F	E	D	C	B	A	NO OF POSN
							PART NUMBER

THIS DRAWING IS A CONTROLLED DOCUMENT.

DIN L VARELA - DOCKS 01-11-05
 CHK S BOLASH 01-11-05
 APVD M WALMSLEY 01-11-05

TE Connectivity

NAME: HEADER ASSY, UNIVERSAL, AMP-LATCH

PRODUCT SPEC: 108-40018

APPLICATION SPEC: -

SIZE: A1

WEIGHT: -

CUSTOMER DRAWING

SCALE: 4:1

SHEET: 1 OF 1

REV: C1