



# EJECT-A-DIP™ Lock/Eject DIP Socket w/Collet Contacts & Wire Wrap Pins

## FEATURES

- Rugged, Solderable Socket with a Unique Ejector/Latch for Fast In-field Board Maintenance
- Latch Locks-in Connector or Device for High-vibration Environments
- Ejector/Latch removes DIP Packages without Damage

## GENERAL SPECIFICATIONS

- LATCH & BODY: Black UL 94V-0 Glass-filled 4/6 Nylon
- PIN BODY: Brass 360 1/2-hard per UNS C36000 ASTM B16/B16M-05
- PIN BODY PLATING: 10μ [0.25μ] min. Au per MIL-G-45204 –OR– 200μ [5.08μ] min. 93/7 Sn/Pb per ASTM B545 –OR– 200μ [5.08μ] min. Sn per ASTM B545 Type 1 over 100μ [2.54μ] min. Ni per SAE AMS-QQ-N-290B
- 6-FINGER COLLECT CONTACTS: BeCu per UNS C17200 ASTM B194-08
- CONTACT PLATING: 30μ [0.76μ] min. Au per MIL-G-45204 over 50μ [1.27μ] min. Ni per SAE AMS-QQ-N-290B
- CONTACT CURRENT RATING: 3 amps
- INSULATION RESISTANCE: 10,000 MΩ at 500VDC
- WITHSTANDING VOLTAGE: 1000Vrms
- OPERATING TEMPERATURE: -67°F to 221°F [-55°C to 105°C] for Sn plating; -67°F to 257°F [-55°C to 125°C] for Au plating
- INSERTION FORCE: 67g/pin, based on 0.018 [0.46] dia. test lead
- WITHDRAWAL FORCE: 30g/pin, based on 0.018 [0.46] dia. test lead
- NORMAL FORCE: 45g/pin, based on 0.018 [0.46] dia. test lead

## MOUNTING CONSIDERATIONS

- SUGGESTED PCB HOLE SIZE: 0.045 ±0.002 [1.15 ±0.05] dia.

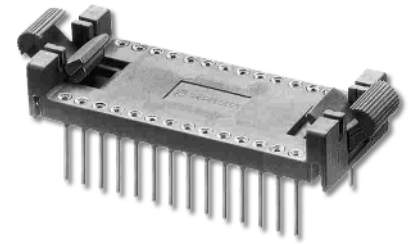

## ORDERING INFORMATION

**XX-CXXX-X XXX**

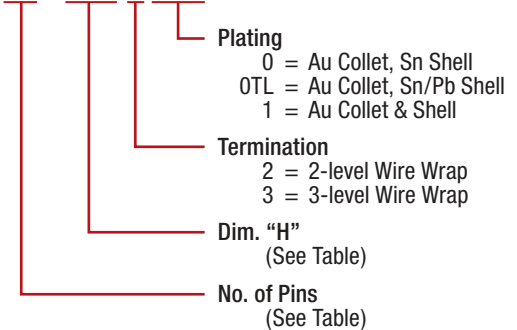

ALL DIMENSIONS: INCHES [MILLIMETERS]  
 ALL TOLERANCES: ±0.005 [0.13] UNLESS OTHERWISE SPECIFIED  
 FOR COLLECT SOCKETS w/SURFACE MOUNT PINS, SEE [DATA SHEET 12023](#)  
 FOR COLLET SOCKET w/SOLDER PIN TAILS, SEE [DATA SHEET 12024](#)  
 CONSULT FACTORY FOR OTHER SIZES AND CONFIGURATIONS

CUSTOMIZATION: ARIES SPECIALIZES IN CUSTOM DESIGN AND PRODUCTION. SPECIAL MATERIALS, PLATINGS, SIZES, AND CONFIGURATIONS CAN BE FURNISHED, DEPENDING ON QUANTITY.  
 ARIES RESERVES THE RIGHT TO CHANGE PRODUCT GENERAL SPECIFICATIONS WITHOUT NOTICE  
 PRINTOUTS OF THIS DOCUMENT MAY BE OUT-OF-DATE AND SHOULD BE CONSIDERED UNCONTROLLED



**ARIES**  
 ELECTRONICS, INC.

2609 Bartram Road • Bristol, PA 19007-6810 USA  
 TEL 215-781-9956 • FAX 215-781-9845  
[WWW.ARIESELEC.COM](http://WWW.ARIESELEC.COM) • [INFO@ARIESELEC.COM](mailto:INFO@ARIESELEC.COM)



12025  
 Rev. 6.2  
 1 of 2



# EJECT-A-DIP™ Lock/Eject DIP Socket w/Collet Contacts & Wire Wrap Pins

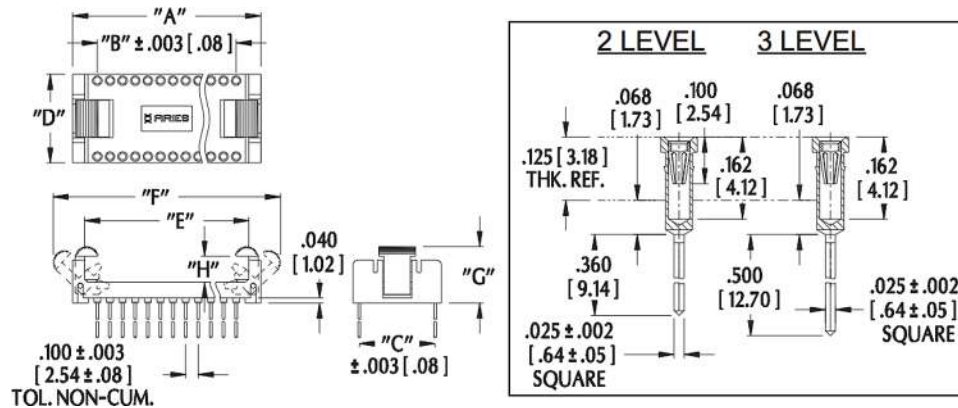

No. of Pins	Catalog No.	Dim. "A"	Dim. "B"	Centers "C"	Dim. "D"	Dim. "E"	Dim. "F"	Dim "G"	Dim "H"
14	14-C280-XX	0.950 [24.10]	0.600 [15.24]	0.300 [7.62]	0.400 [10.16]	0.770 [19.56]	1.300 [33.02]	0.490 [12.45]	0.280 [7.11]
14	14-C195-XX	0.950 [24.10]	0.600 [15.24]	0.300 [7.62]	0.400 [10.16]	0.770 [19.56]	1.300 [33.02]	0.450 [11.43]	0.195 [4.95]
16	16-C280-XX	1.050 [26.70]	0.700 [17.78]	0.300 [7.62]	0.400 [10.16]	0.870 [22.10]	1.540 [39.12]	0.490 [12.45]	0.280 [7.11]
16	16-C195-XX	1.050 [26.70]	0.700 [17.78]	0.300 [7.62]	0.400 [10.16]	0.870 [22.10]	1.390 [35.31]	0.450 [11.43]	0.195 [4.95]
24	24-C300-XX	1.490 [37.85]	1.100 [27.94]	0.600 [15.24]	0.700 [17.78]	1.300 [33.02]	1.970 [50.04]	0.570 [14.48]	0.300 [7.62]
24	24-C212-XX	1.490 [37.85]	1.100 [27.94]	0.600 [15.24]	0.700 [17.78]	1.300 [33.02]	1.850 [47.00]	0.490 [12.45]	0.212 [5.39]
24	24-C182-XX	1.490 [37.85]	1.100 [27.94]	0.600 [15.24]	0.700 [17.78]	1.300 [33.02]	1.800 [45.72]	0.460 [11.68]	0.182 [4.62]
28	28-C300-XX	1.690 [42.90]	1.300 [33.02]	0.600 [15.24]	0.700 [17.78]	1.500 [38.10]	2.170 [55.12]	0.570 [14.48]	0.300 [7.62]
28	28-C212-XX	1.690 [42.90]	1.300 [33.02]	0.600 [15.24]	0.700 [17.78]	1.500 [38.10]	2.050 [52.07]	0.490 [12.45]	0.212 [5.39]
28	28-C182-XX	1.690 [42.90]	1.300 [33.02]	0.600 [15.24]	0.700 [17.78]	1.500 [38.10]	2.000 [50.80]	0.460 [11.68]	0.182 [4.62]
32	32-C300-XX	1.890 [48.00]	1.500 [38.10]	0.600 [15.24]	0.700 [17.78]	1.700 [43.18]	2.540 [64.52]	0.570 [14.48]	0.300 [7.62]
32	32-C212-XX	1.890 [48.00]	1.500 [38.10]	0.600 [15.24]	0.700 [17.78]	1.700 [43.18]	2.070 [52.58]	0.490 [12.45]	0.212 [5.39]
32	32-C182-XX	1.890 [48.00]	1.500 [38.10]	0.600 [15.24]	0.700 [17.78]	1.700 [43.18]	2.200 [55.88]	0.460 [11.68]	0.182 [4.62]
40	40-C300-XX	2.290 [58.20]	1.900 [48.26]	0.600 [15.24]	0.700 [17.78]	2.100 [53.34]	2.780 [70.61]	0.570 [14.48]	0.300 [7.62]
40	40-C212-XX	2.290 [58.20]	1.900 [48.26]	0.600 [15.24]	0.700 [17.78]	2.100 [53.34]	2.650 [67.31]	0.490 [12.45]	0.212 [5.39]
40	40-C182-XX	2.290 [58.20]	1.900 [48.26]	0.600 [15.24]	0.700 [17.78]	2.100 [53.34]	2.600 [66.04]	0.460 [11.68]	0.182 [4.62]

ALL DIMENSIONS: INCHES [MILLIMETERS]  
 ALL TOLERANCES: ±0.005 [0.13] UNLESS OTHERWISE SPECIFIED  
 FOR COLLECT SOCKETS w/SURFACE MOUNT PINS, SEE [DATA SHEET 12023](#)  
 FOR COLLET SOCKET w/SOLDER PIN TAILS, SEE [DATA SHEET 12024](#)  
 CONSULT FACTORY FOR OTHER SIZES AND CONFIGURATIONS

CUSTOMIZATION: ARIES SPECIALIZES IN CUSTOM DESIGN AND PRODUCTION. SPECIAL MATERIALS, PLATINGS, SIZES, AND CONFIGURATIONS CAN BE FURNISHED, DEPENDING ON QUANTITY.  
 ARIES RESERVES THE RIGHT TO CHANGE PRODUCT GENERAL SPECIFICATIONS WITHOUT NOTICE  
 PRINTOUTS OF THIS DOCUMENT MAY BE OUT-OF-DATE AND SHOULD BE CONSIDERED UNCONTROLLED



2609 Bartram Road • Bristol, PA 19007-6810 USA  
 TEL 215-781-9956 • FAX 215-781-9845  
[WWW.ARIESELEC.COM](http://WWW.ARIESELEC.COM) • [INFO@ARIESELEC.COM](mailto:INFO@ARIESELEC.COM)

