

TAP-213 Series

Railway onboard 802.11n IP68 wireless AP/client



- > IEEE 802.11a/b/g/n compliant
- > Can be powered by redundant dual DC power inputs or PoE
- > QoS (WMM) and VLAN for efficient network traffic
- > Controller-based Turbo Roaming
- > Complies with all EN 50155 mandatory test items*
- > Rugged IP68-rated housing and -40 to 75°C operating temperature
- > Wireless network redundancy with AeroLink protection

*This product is suitable for rolling stock railway applications, as defined by the EN 50155 standard. For a more detailed statement, click here: www.moxa.com/doc/specs/EN_50155_Compliance.pdf



Introduction

The TAP-213 outdoor wireless AP/client is the ideal ruggedized wireless solution for railway onboard train-to-ground applications such as CCTV and CBTC communications. The TAP-213's dust-tight, weatherproof design is IP68-rated, allowing you to extend wireless networks to outdoor locations and critical environments. The two redundant DC power inputs increase the reliability of the power supply and the device can also be powered via PoE for easier deployment. The TAP-213 is compliant with industrial standards and railway approvals covering operating temperature, power input voltage, surge, ESD, and vibration. With many hardened industrial-grade features, the TAP-213 will provide stable and reliable wireless connectivity, especially for railway onboard environments.

Features for Critical Environments

- IP68-rated metal housing and -40 to 75°C wide operating temperature
- Anti-vibration M12 design and waterproof/dust-tight connectors
- PoE and dual DC power inputs

Specifications for Railway Applications

- High power 400 mW (max.) radio
- Wide range power input from 24 to 110 VDC
- Client-based Turbo Roaming handover time less than 150 ms with 1 channel and WPA2, and less than 350 ms with 3 channels and WPA2
- Controller-based Turbo Roaming handover time (available only when used with the WAC-1001 or WAC-2004) less than 50 ms with 3 channels and WPA2
- Multiple roaming parameters for different installation structures and antenna types

Specifications

WLAN Interface

Standards:

IEEE 802.11a/b/g/n for Wireless LAN
 IEEE 802.11i for Wireless Security
 IEEE 802.3 for 10BaseT
 IEEE 802.3u for 100BaseT(X)
 IEEE 802.3ab for 1000BaseT
 IEEE 802.3af for Power-over-Ethernet
 IEEE 802.1D for Spanning Tree Protocol
 IEEE 802.1w for Rapid STP
 IEEE 802.1p for Class of Service
 IEEE 802.1Q for VLAN

Spread Spectrum and Modulation (typical):

- DSSS with DBPSK, DQPSK, CCK
- OFDM with BPSK, QPSK, 16QAM, 64QAM
- 802.11b: CCK @ 11/5.5 Mbps, DQPSK @ 2 Mbps, DBPSK @ 1 Mbps
- 802.11a/g: 64QAM @ 54/48 Mbps, 16QAM @ 36/24 Mbps, QPSK @ 18/12 Mbps, BPSK @ 9/6 Mbps
- 802.11n: 64QAM @ 300 Mbps to BPSK @ 6.5 Mbps (multiple rates supported)

Operating Channels (central frequency):

- US:
 - 2.412 to 2.462 GHz (11 channels)
 - 5.180 to 5.240 GHz (4 channels)
 - 5.260 to 5.320 GHz (4 channels)*
 - 5.500 to 5.700 GHz (8 channels; excludes 5.600 to 5.640 GHz)*
 - 5.745 to 5.825 GHz (5 channels)
- EU:
 - 2.412 to 2.472 GHz (13 channels)
 - 5.180 to 5.240 GHz (4 channels)
 - 5.260 to 5.320 GHz (4 channels)*
 - 5.500 to 5.700 GHz (11 channels)*
- JP:
 - 2.412 to 2.484 GHz (14 channels, DSSS)
 - 5.180 to 5.240 GHz (4 channels)
 - 5.260 to 5.320 GHz (4 channels)*
 - 5.500 to 5.700 GHz (11 channels)*

*Special frequency bands (up to 6.0 GHz) are available for customization.

Security:

- SSID broadcast enable/disable
- Firewall for MAC/IP/Protocol/Port-based filtering
- 64-bit and 128-bit WEP encryption, WPA /WPA2 Personal and Enterprise (IEEE 802.1X/RADIUS, TKIP and AES)

Transmission Rates:

- 802.11b: 1, 2, 5.5, 11 Mbps
- 802.11a/g: 6, 9, 12, 18, 24, 36, 48, 54 Mbps
- 802.11n: 6.5 to 300 Mbps (multiple rates supported)

Transmitter Power:

- 802.11b:
- Typ. 26±1.5 dBm @ 1 Mbps
 - Typ. 26±1.5 dBm @ 2 Mbps
 - Typ. 26±1.5 dBm @ 5.5 Mbps
 - Typ. 25±1.5 dBm @ 11 Mbps
- 802.11g:
- Typ. 23±1.5 dBm @ 6 to 24 Mbps
 - Typ. 21±1.5 dBm @ 36 Mbps
 - Typ. 19±1.5 dBm @ 48 Mbps
 - Typ. 18±1.5 dBm @ 54 Mbps
- 802.11n (2.4 GHz):
- Typ. 23±1.5 dBm @ MCS0/8 20 MHz
 - Typ. 18±1.5 dBm @ MCS7/15 20 MHz
 - Typ. 23±1.5 dBm @ MCS0/8 40 MHz
 - Typ. 17±1.5 dBm @ MCS7/15 40 MHz
- 802.11a:
- Typ. 23±1.5 dBm @ 6 to 24 Mbps
 - Typ. 21±1.5 dBm @ 36 Mbps
 - Typ. 20±1.5 dBm @ 48 Mbps
 - Typ. 18±1.5 dBm @ 54 Mbps
- 802.11n (5 GHz):
- Typ. 23±1.5 dBm @ MCS0/8 20 MHz
 - Typ. 18±1.5 dBm @ MCS7/15 20 MHz
 - Typ. 23±1.5 dBm @ MCS0/8 40 MHz
 - Typ. 18±1.5 dBm @ MCS7/15 40 MHz

Receiver Sensitivity:

- 802.11b:
- -93 dBm @ 1 Mbps
 - -93 dBm @ 2 Mbps
 - -93 dBm @ 5.5 Mbps
 - -88 dBm @ 11 Mbps
- 802.11g:
- -88 dBm @ 6 Mbps
 - -86 dBm @ 9 Mbps
 - -85 dBm @ 12 Mbps
 - -85 dBm @ 18 Mbps
 - -85 dBm @ 24 Mbps
 - -82 dBm @ 36 Mbps
 - -78 dBm @ 48 Mbps
 - -74 dBm @ 54 Mbps
- 802.11n (2.4 GHz):
- -70 dBm @ MCS7 20 MHz
 - -69 dBm @ MCS15 20 MHz
 - -67 dBm @ MCS7 40 MHz
 - -67 dBm @ MCS15 40 MHz
- 802.11a:
- -90 dBm @ 6 Mbps
 - -88 dBm @ 9 Mbps
 - -88 dBm @ 12 Mbps
 - -85 dBm @ 18 Mbps
 - -81 dBm @ 24 Mbps
 - -78 dBm @ 36 Mbps
 - -74 dBm @ 48 Mbps
 - -74 dBm @ 54 Mbps
- 802.11n (5 GHz):
- -69 dBm @ MCS7 20 MHz
 - -71 dBm @ MCS15 20 MHz
 - -63 dBm @ MCS7 40 MHz
 - -68 dBm @ MCS15 40 MHz

Protocol Support

General Protocols: Proxy ARP, DNS, HTTP, HTTPS, IP, ICMP, SNMP, TCP, UDP, RADIUS, SNMP, PPPoE, DHCP

AP-only Protocols: ARP, BOOTP, DHCP, STP/RSTP (IEEE 802.1D/w)

Interface

LAN Ports: 1, M12 X-coded 8-pin female connector, 10/100/1000BaseT(X) auto negotiation speed, F/H duplex mode, and auto MDI/MDI-X connection

Console Port: M12 B-coded 5-pin female connector for the USB console

USB Port: M12 A-coded 5-pin female connector for ABC-02 USB storage

Reset: Present

LED Indicators: PWR, FAULT, STATE, WLAN, LAN 1, LAN 2

Fiber Port: 100/1000Base SFP slot

Connector for External Antennas: N-type (female)

Physical Characteristics

Housing: Metal, IP68 protection

Weight: 1500 g (3.31 lb)

Dimensions: 220 x 150 x 50.5 mm (8.66 x 5.90 x 1.99 in)

Installation: Wall mounting (standard), DIN-rail mounting (optional), pole mounting (optional)

Environmental Limits

Operating Temperature: -40 to 75°C (-40 to 167°F)

Storage Temperature: -40 to 85°C (-40 to 185°F)

Ambient Relative Humidity: 5% to 95% (non-condensing)

Power Requirements

Input Voltage: 24 to 110 VDC, redundant dual DC power inputs or 48 VDC Power-over-Ethernet (IEEE 802.3af compliant)

Input Current: 0.65 A @ 24 VDC, 0.16 A @ 110 VDC

Connector: M12 A-coded 4-pin male connector

Power Consumption: 17.6 W (max.)

Reverse Polarity Protection: Present

Standards and Certifications

Safety: UL 60950-1, IEC 60950-1(CB), LVD EN 60950-1

EMC: EN 61000-6-2/6-4

EMI: CISPR 22, FCC Part 15B Class A

EMS:

IEC 61000-4-2 ESD: Contact: 6 kV; Air: 8 kV

IEC 61000-4-3 RS: 80 MHz to 1 GHz: 20 V/m

IEC 61000-4-4 EFT: Power: 2 kV; Signal: 2 kV

IEC 61000-4-5 Surge: Power: 2 kV; Signal: 2 kV

IEC 61000-4-6 CS: 10 V

IEC 61000-4-8

Radio: EN 301 489-1/17, EN 300 328, EN 301 893, TELEC, DFS, FCC ID SLE-WAPN008

Rail Traffic: EN 50155*, EN 50121-4

Fire and Smoke: EN 45545-2

*This product is suitable for rolling stock railway applications, as defined by the EN 50155 standard. For a more detailed statement, click here: www.moxa.com/doc/specs/EN_50155_Compliance.pdf

MTBF (mean time between failures)

Time: 758,369 hrs

Standard: Telcordia SR332

Warranty

Warranty Period: 5 years

Details: See www.moxa.com/warranty

Dimensions

Unit: mm (inch)

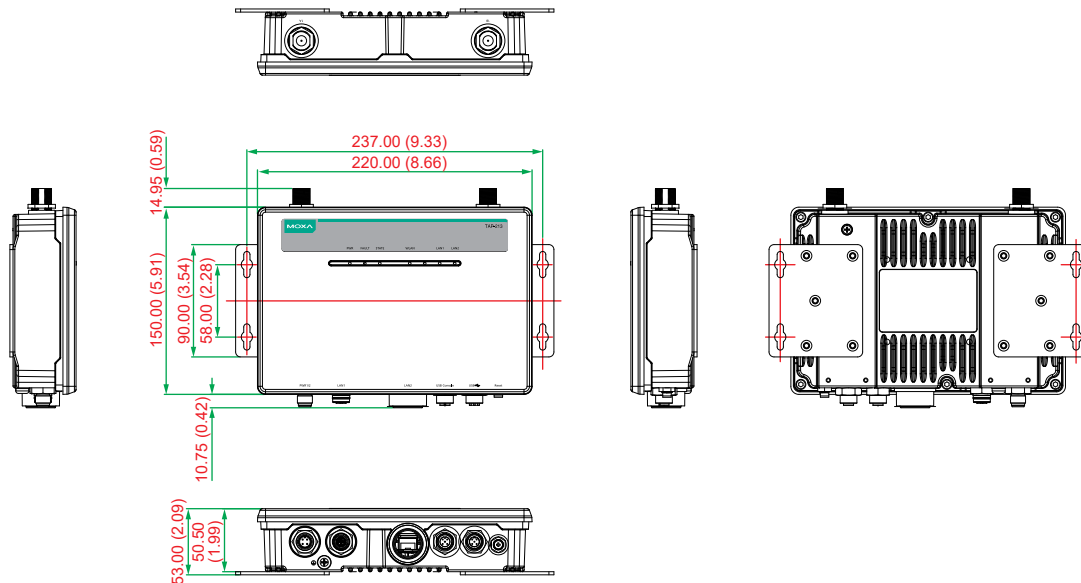

Ordering Information

Available Models

TAP-213-EU-CT-T: Railway onboard 802.11n IP68 wireless AP/client, EU band, -40 to 75°C operating temperature, conformal coating

TAP-213-US-CT-T: Railway onboard 802.11n IP68 wireless AP/client, US band, -40 to 75°C operating temperature, conformal coating

TAP-213-JP-CT-T: Railway onboard 802.11n IP68 wireless AP/client, JP band, -40 to 75°C operating temperature, conformal coating

Note: Please visit Moxa's website for a complete list of optional wireless accessories and antennas available for Moxa's wireless products.

Recommended SFP-1G Series Modules

SFP-1GSXLC-T: SFP module with 1 1000BaseSX port with LC connector for 0.5 km transmission and -20 to 85°C operating temperature range

SFP-1GLSXL-T: SFP module with 1 1000BaseLSX port with LC connector for 2 km transmission and -40 to 85°C operating temperature range

SFP-1GLXL-T: SFP module with 1 1000BaseLX port with LC connector for 10 km transmission and -40 to 85°C operating temperature range

SFP-1GLHL-T: SFP module with 1 1000BaseLH port with LC connector for 40 km transmission and -40 to 85°C operating temperature range

Package Checklist

- 1 TAP-213
- 1 wall-mounting kit, including 2 plates
- 1 plastic protective cap for LAN-1 X-coded port
- 3 metal protective caps for LAN-2 fiber port, USB console port, and ABC-02 USB storage port
- 1 metal M12 male 4-pin A-coded screw-type crimp circular connector for power
- 2 antennas, supporting both 2.4 GHz and 5 GHz
- Quick installation guide (printed)
- Warranty card

Railway Access Point Accessories

: M12/M23 Cords

CBL-M12XMM8P-Y-300-IP67

3-meter M12-to-M12 Cat-5 UTP Ethernet cable with IP67-rated 8-pin male X-coded crimp type M12 connector



CBL-M12XMM8PRJ45-Y-200-IP67

2-meter M12-to-RJ45 Cat-5 UTP Ethernet cable with IP67-rated 8-pin male X-coded crimp type M12 connector



CBL-M12XMM8P-Y-100-IP67

1-meter M12-to-M12 Cat-5 UTP Ethernet cable with IP67-rated 8-pin male X-coded crimp type M12 connector



: M12 Connectors

M12X-8PMM-IP67-HTG

Field-installable M12 X-coded crimp type, slim design connector, 8-pin male, IP67-rated



: M12 IP67 Protective Caps

A-CAP-M12F-M

Metal cap for M12 female connector



A-CAP-M12M-M

Metal cap for M12 male connector

