



Vacuum NEMA contactor, Size 5, Three phase full voltage, Contactor amp rating 270A, 3 wire (NO aux included), 220-240V 50-60Hz/DC coil, Non-combination type, Enclosure NEMA type (open), No enclosure

product brand name	Class 40
design of the product	Non-reversing vacuum contactor
special product feature	Latest technology in arc quenching to extend contactor life; Same coil voltage is AC or DC
<b>General technical data</b>	
weight [lb]	16 lb
Height x Width x Depth [in]	0 × 0 × 0 in
touch protection against electrical shock	Main circuit (not finger-safe); Control circuit (finger-safe)
installation altitude [ft] at height above sea level maximum	6560 ft
ambient temperature [°F]	
• during storage	-22 ... +149 °F
• during operation	-4 ... +104 °F
ambient temperature	
• during storage	-30 ... +65 °C
• during operation	-20 ... +40 °C
country of origin	Germany
<b>Horsepower ratings</b>	
yielded mechanical performance [hp] for 3-phase AC motor	
• at 200/208 V rated value	75 hp
• at 220/230 V rated value	100 hp
• at 460/480 V rated value	200 hp
• at 575/600 V rated value	200 hp
<b>Contactors</b>	
size of contactor	NEMA controller size 5
number of NO contacts for main contacts	3
operating voltage for main current circuit at AC at 60 Hz maximum	600 V
operational current at AC at 600 V rated value	270 A
mechanical service life (operating cycles) of the main contacts typical	10000000
<b>Auxiliary contact</b>	
number of NC contacts at contactor for auxiliary contacts	2
number of NO contacts at contactor for auxiliary contacts	2
number of total auxiliary contacts maximum	8
contact rating of auxiliary contacts of contactor according to UL	10A@240VAC (A300), 2.5A@250VDC (Q300)
<b>Coil</b>	
type of voltage of the control supply voltage	AC/DC
control supply voltage	
• at DC rated value	220 ... 240 V
• at AC at 50 Hz rated value	220 ... 240 V
• at AC at 60 Hz rated value	220 ... 240 V

holding power at AC minimum	7.4 W
apparent pick-up power of magnet coil at AC	590 VA
apparent holding power of magnet coil at AC	6.7 VA
operating range factor control supply voltage rated value of magnet coil	0.85 ... 1.1
percentual drop-out voltage of magnet coil related to the input voltage	60 %
ON-delay time	30 ... 95 ms
OFF-delay time	40 ... 80 ms

#### Enclosure

degree of protection NEMA rating of the enclosure	Open device (no enclosure)
design of the housing	NA

#### Mounting/wiring

mounting position	Vertical
fastening method	Surface mounting and installation
type of electrical connection for supply voltage line-side	Bus Bar (M10x30 hexagon socket A/F17)
tightening torque [lbf-in] for supply	140 ... 240 lbf-in
type of connectable conductor cross-sections at line-side for AWG cables single or multi-stranded	2/0 AWG ... 500 kcmil
type of electrical connection for load-side outgoing feeder	Bus Bar (M10x30 hexagon socket A/F17)
tightening torque [lbf-in] for load-side outgoing feeder	140 ... 240 lbf-in
type of connectable conductor cross-sections for AWG cables for load-side outgoing feeder single or multi-stranded	2/0 AWG ... 500 kcmil
type of electrical connection of magnet coil	Screw-type terminals
tightening torque [lbf-in] at magnet coil	7 ... 10 lbf-in
type of connectable conductor cross-sections of magnet coil for AWG cables single or multi-stranded	2x (18 ... 14 AWG)
temperature of the conductor at magnet coil maximum permissible	75 °C
material of the conductor at magnet coil	CU
type of electrical connection at contactor for auxiliary contacts	Screw-type terminals
tightening torque [lbf-in] at contactor for auxiliary contacts	7 ... 10 lbf-in
type of connectable conductor cross-sections at contactor for AWG cables for auxiliary contacts single or multi-stranded	2x (20 ... 16 AWG), 2x (18 ... 14 AWG)
temperature of the conductor at contactor for auxiliary contacts maximum permissible	75 °C
material of the conductor at contactor for auxiliary contacts	CU

#### Short-circuit current rating

design of the fuse link for short-circuit protection of the main circuit required	5kA@600V
design of the short-circuit trip	Thermal magnetic circuit breaker
maximum short-circuit current breaking capacity (Icu)	
• at 240 V	5 A
• at 480 V	5 A
• at 600 V	5 A
certificate of suitability	NEMA ICS 2; UL 508; CSA 22.2, No.14

#### Further information

**Industrial Controls - Product Overview (Catalogs, Brochures,...)**

[www.usa.siemens.com/iccatalog](http://www.usa.siemens.com/iccatalog)

**Industry Mall (Online ordering system)**

<https://mall.industry.siemens.com/mall/en/us/Catalog/product?mlfb=US2:40LV32AG>

**Service&Support (Manuals, Certificates, Characteristics, FAQs,...)**

<https://support.industry.siemens.com/cs/US/en/ps/US2:40LV32AG>

**Image database (product images, 2D dimension drawings, 3D models, device circuit diagrams, EPLAN macros, ...)**

[http://www.automation.siemens.com/bilddb/cax\\_de.aspx?mlfb=US2:40LV32AG&lang=en](http://www.automation.siemens.com/bilddb/cax_de.aspx?mlfb=US2:40LV32AG&lang=en)

**Certificates/approvals**

<https://support.industry.siemens.com/cs/US/en/ps/US2:40LV32AG/certificate>

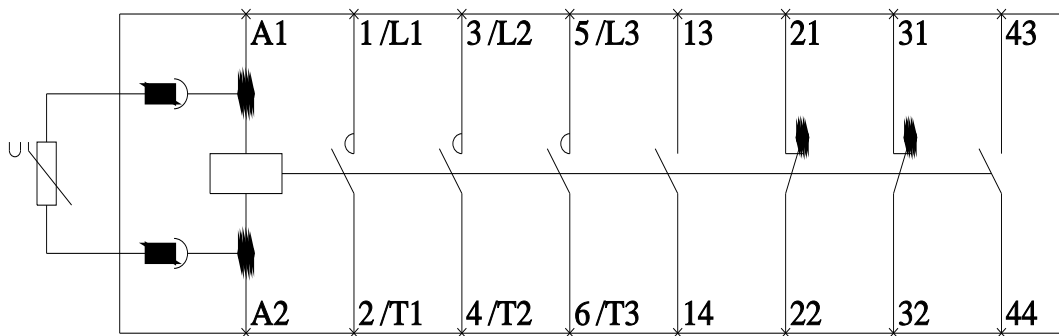
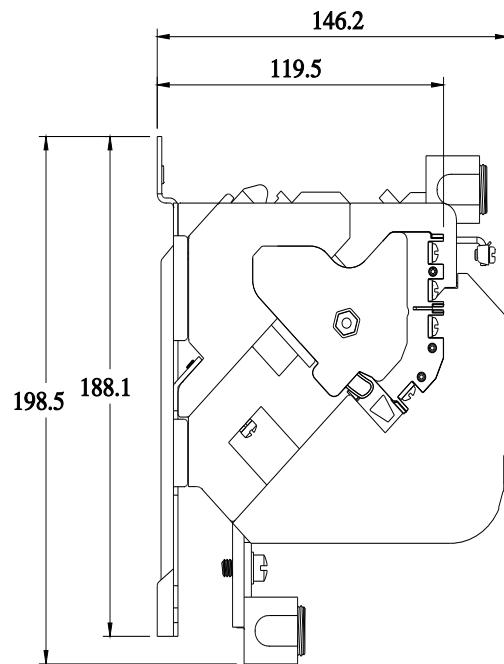
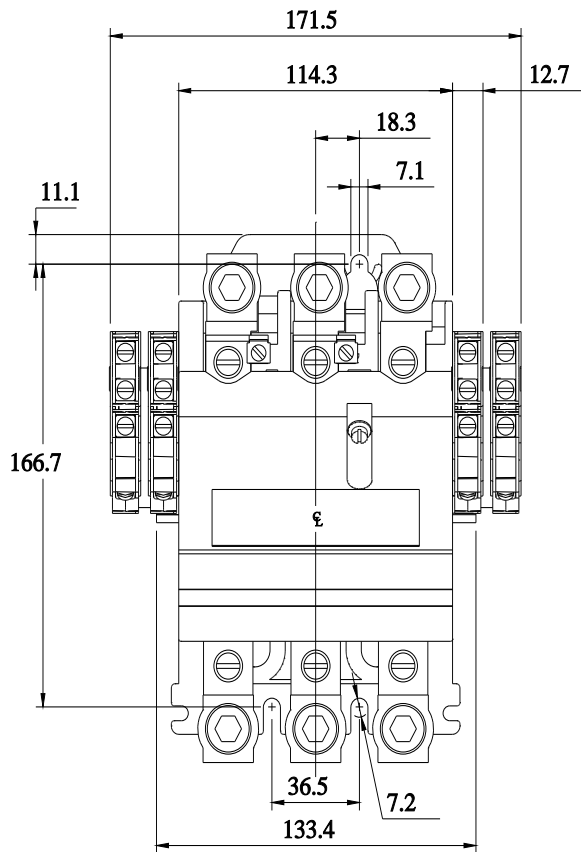

NEMAVacuumContactorWD

