

# Advantech

## AQD-SD4U4GE24-HG Datasheet

Rev. 0.0

2016-12-13

## Description

AQD-SD4U4GE24-HG is a DDR4 2400Mbps SO-DIMM high-speed, memory module that use 9pcs of 512M x 8 bits DDR4 SDRAM in FBGA package and a 4K bits serial EEPROM on a 260-pin printed circuit board.

AQD-SD4U4GE24-HG is a Dual In-Line Memory Module and is intended for mounting into 260-pin edge connector sockets.

Synchronous design allows precise cycle control with the use of system clock. Data I/O transactions are possible on both edges of DQS. Range of operation frequencies, programmable latencies allow the same device to be useful for a variety of high bandwidth, high performance memory system applications.

## Features

- RoHS compliant products.
- JEDEC standard 1.2V(1.14V~1.26V) Power supply  
VDDQ= 1.2V(1.14V~1.26V)
- VPP = 2.5V +0.25V / -0.125V
- Data transfer rates: PC3-12800  
Programmable CAS Latency:  
10,11,12,13,14,15,16,17,18
- 8 bit pre-fetch
- Burst Length (BL) switch on-the-fly BL8 or BC4
- Bi-directional Differential Data-Strobe
- On Die Termination, Nominal, Park, and Dynamic ODT
- Serial presence detect with EEPROM  
Asynchronous reset
- PCB edge connector treated with 30u" Gold-Plating

## Pin Identification

Symbol	Function
A0~A17 <sup>1</sup> , BA0~BA1	Address/Bank input
DQ0~DQ63	Bi-direction data bus.

DQS0_t~DQS17_t	Data Buffer data strobes
DQS0_c~DQS17_c	Data Buffer data strobes
CK0_t, CK1_t	Register clock input
CK0_c, CK1_c	Register clocks input
ODT0 & ODT1	On-die termination control line
CS0_n~CS3_n	DIMM Rank Select Lines input.
RAS_n <sup>2</sup>	Row address strobe
CAS_n <sup>3</sup>	Column address strobe
WE_n <sup>4</sup>	Write Enable
DM0~DM7	Data masks/high data strobes
VDD	Core power supply
VDDQ	I/O driver power supply
V <sub>REF</sub> CA	Command/address reference supply
V <sub>DD</sub> SPD	SPD EEPROM power supply
SA0~SA2	I2C serial bus address select for EEPROM
SCL	I2C serial bus clock for EEPROM
SDA	I2C serial bus data for EEPROM
VSS	Ground
RESET_n	Set DRAMs Known State
VTT	DRAM I/O termination supply
VPP	SDRAM Supply
ALERT_n	Register ALERT_n output
EVENT_n	SPD signals a thermal event has occurred
RFU	Reserved for future use

1. Address A17 is only valid for 16 Gb x4 based SDRAMs.
2. RAS\_n is a multiplexed function with A16.
3. CAS\_n is a multiplexed function with A15.
4. WE\_n is a multiplexed function with A14.





Enabling an Intelligent Planet

260Pin DDR4 2400 1.2V SO-DIMM

4GB Based on 512Mx8

AQD-SD4U4GE24-HG

Pin Assignments

Pin	Front	Pin	Front	Pin	Front	Pin	Back	Pin	Back	Pin	Back	Pin	Back
1	12V	41	DQ10	81	VSS	121	A9	161	ODT1	201	VSS	241	M7_n/D17_c
2	VSS	42	DQ11	82	VSS	122	A7	162	C0_CS2_n,NC	202	VSS	242	DQS7_t
3	DQ5	43	VSS	83	DQ26	123	VSS	163	VDD	203	DQ46	243	VSS
4	DQ4	44	VSS	84	DQ27	124	DQ54	164	VREFCA	204	DQ47	244	VSS
5	VSS	45	DQ21	85	VSS	125	VSS	165	C1_CS3_n,NC	205	VSS	245	DQ62
6	VSS	46	DQ20	86	VSS	126	DQ50	166	SA2	206	VSS	246	DQ63
7	DQ1	47	VSS	87	CB5, NC	127	VSS	167	VSS	207	DQ42	247	VSS
8	DQ0	48	VSS	88	CB4, NC	128	DQ60	168	VSS	208	DQ43	248	VSS
9	VSS	49	DQ17	89	VSS	129	VDD	169	DQ37	209	VSS	249	DQ58
10	VSS	50	DQ16	90	VSS	130	VDD	170	DQ36	210	VSS	250	DQ59
11	DQ S0_c	51	VSS	91	CB1, NC	131	A3	171	VSS	211	DQ52	251	VSS
12	D M0_n/D B10_n, NC	52	VSS	92	CB0, NC	132	A2	172	VSS	212	DQ53	252	VSS
13	DQS0_t	53	DQ S2_c	93	VSS	133	A1	173	DQ33	213	VSS	253	SCL
14	VSS	54	D M2_n/D B12_n, NC	94	VSS	134	EVENT_n	174	DQ32	214	VSS	254	SDA
15	VSS	55	DQS2_t	95	DQ S8_c	135	VDD	175	VSS	215	DQ49	255	VDDSPD
16	DQ6	56	VSS	96	D M8_n/D B18_n, NC	136	VDD	176	VSS	216	DQ48	256	SA0
17	DQ7	57	VSS	97	DQ S8_t	137	CK0_t	177	DQS4_c	217	VSS	257	VPP
18	VSS	58	DQ22	98	VSS	138	CK1_t	178	M4_n/D B14_c	218	VSS	258	VTT
19	VSS	59	DQ23	99	VSS	139	CK0_c	179	DQS4_t	219	DQS6_c	259	VPP
20	DQ2	60	VSS	100	CB6, NC	140	CK1_c	180	VSS	220	D M6_n/D B16_n, NC	260	SA1
21	DQ3	61	VSS	101	CB2, NC	141	VDD	181	VSS	221	DQS6_t		
22	VSS	62	DQ18	102	VSS	142	VDD	182	DQ39	222	VSS		
23	VSS	63	DQ19	103	VSS	143	PARITY	183	DQ38	223	VSS		
24	DQ12	64	VSS	104	CB7, NC	144	A0	184	VSS	224	DQ54		
25	DQ13	65	VSS	105	CB3, NC	145	BA1	185	VSS	225	DQ55		
26	VSS	66	DQ28	106	VSS	146	A10/AP	186	DQ35	226	VSS		
27	VSS	67	DQ29	107	VSS	147	VDD	187	DQ34	227	VSS		
28	DQ8	68	VSS	108	RESET_n	148	VDD	188	VSS	228	DQ50		
29	DQ9	69	VSS	109	CKE0	149	CS0_n	189	VSS	229	DQ51		
30	VSS	70	DQ24	110	CKE1	150	BA0	190	DQ45	230	VSS		
31	VSS	71	DQ25	111	VDD	151	A14/WE_n	191	DQ44	231	VSS		
32	DQ S1_c	72	VSS	112	VDD	152	A16/RAS_n	192	VSS	232	DQ60		
33	D M1_n/D B11_n, NC	73	VSS	113	BG1	153	VDD	193	VSS	233	DQ61		
34	DQS1_t	74	DQ S3_c	114	ACT_n	154	VDD	194	DQ41	234	VSS		
35	VSS	75	D M3_n/D B13_n, NC	115	BG0	155	ODT0	195	DQ40	235	VSS		
36	VSS	76	DQ S3_t	116	ALERT_n	156	A15/CAS_n	196	VSS	236	DQ57		
37	DQ15	77	VSS	117	VDD	157	CS1_n	197	VSS	237	DQ56		
38	DQ14	78	VSS	118	VDD	158	A13	198	DQS5_c	238	VSS		
39	VSS	79	DQ30	119	A12	159	VDD	199	M5_n/D B15_c	239	VSS		
40	VSS	80	DQ31	120	A11	160	VDD	200	VSS	240	DQS7_c		

## 4GB, 512Mx9 Module (1 Rank x8)

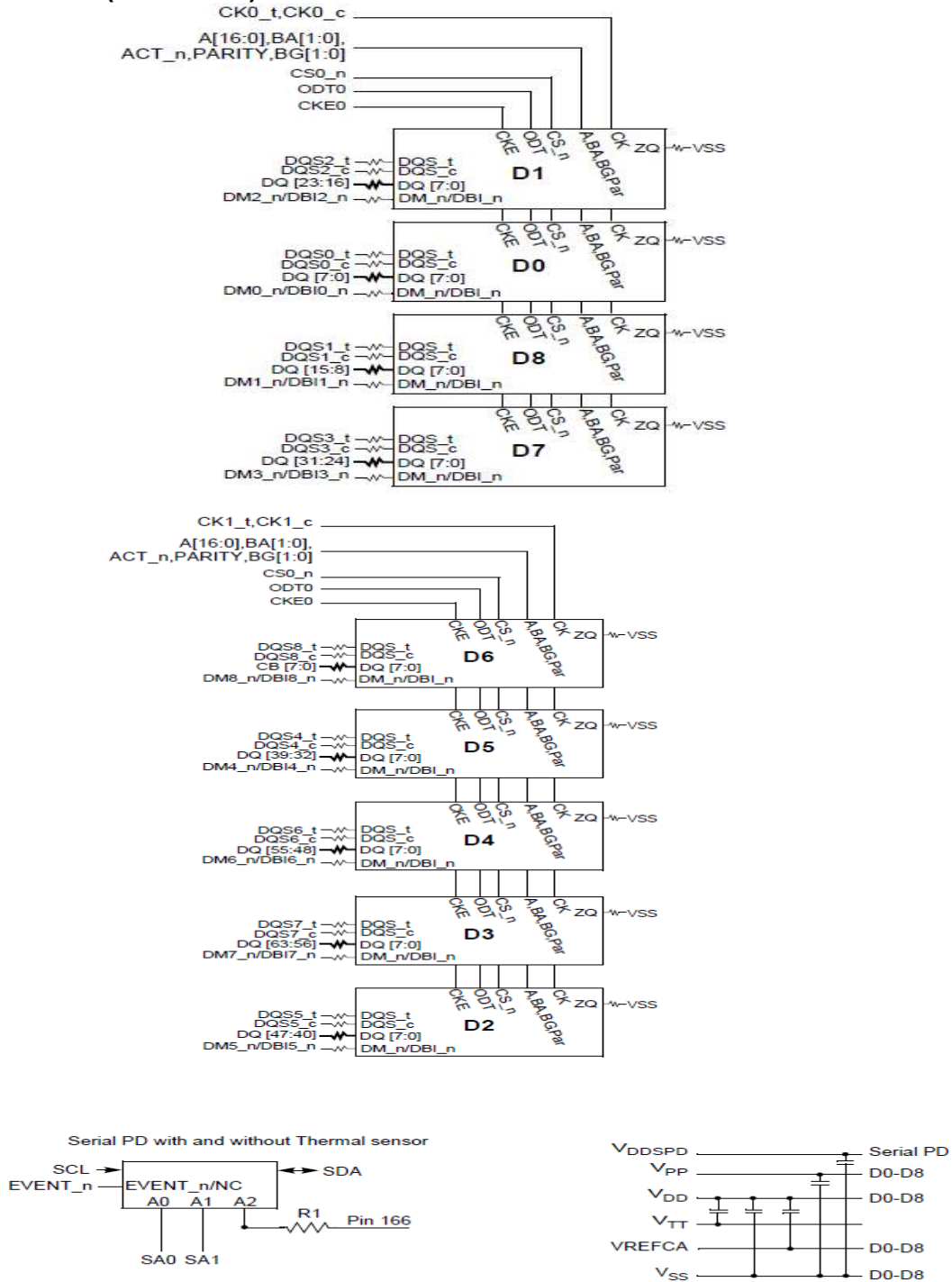

- This technical information is based on industry standard data and tests believed to be reliable. However, Advantech makes no warranties, either expressed or implied, as to its accuracy and assume no liability in connection with the use of this product. Advantech reserves the right to make changes in specifications at any time without prior notice.

### Operating Temperature Condition

Parameter	Symbol	Rating	Unit	Note
Operating Temperature	TOPER	0 to 85	°C	1,2

Note: Operating Temperature is the case surface temperature on the center/top side of the DRAM. For the measurement conditions, please refer to JESD51-2 standard.

### Absolute Maximum DC Ratings

Parameter	Symbol	Value	Unit	Note
Voltage on VDD relative to Vss	VDD	-0.3 ~ 1.5	V	1
Voltage on VDDQ pin relative to Vss	VDDQ	-0.3 ~ 1.5	V	1
Voltage on any pin relative to Vss	VIN, VOUT	-0.3 ~ 1.5	V	1
Storage temperature	TSTG	-55~+100	°C	1,2

Note: 1. Stress greater than those listed under “Absolute Maximum Ratings” may cause permanent damage to the device. This is a stress rating only and functional operation of the device at these or any other conditions above those indicated in the operational sections of this specification is not implied. Exposure to absolute maximum rating conditions for extended periods may affect reliability.  
 2. Storage Temperature is the case surface temperature on the center/top side of the DRAM. For the measurement conditions, please refer to JESD51-2 standard.

### AC & DC Operating Conditions

#### Recommended DC operating conditions

Parameter	Symbol	Voltage	Rating			Unit	Notes
			Min	Typ.	Max		
Supply voltage	VDD	1.2V	1.14	1.2	1.26	V	1,2,3
Supply voltage for Output	VDDQ	1.2V	1.14	1.2	1.26	V	1,2,3
I/O Reference Voltage (DQ)	VREF <sub>DQ</sub> (DC)	1.2V	0.49*VDD	0.50*VDD	0.51*VDD	V	4
I/O Reference Voltage (CMD/ADD)	VREF <sub>CA</sub> (DC)	1.2V	0.49*VDD	0.50*VDD	0.51*VDD	V	4
AC Input Logic High	VIH(AC)	1.2V	VREF+100	-	VDD <sup>2</sup>	mV	
AC Input Logic Low	VIL(AC)	1.2V	VSS <sup>2</sup>	-	VREF-100	mV	
DC Input Logic High	VIH(DC)	1.2V	VREF+75	-	VDD	mV	
DC Input Logic Low	VIL(DC)	1.2V	VSS	-	VREF-75	mV	

Note: (1) Under all conditions VDDQ must be less than or equal to VDD.  
 (2) VDDQ tracks with VDD. AC parameters are measured with VDD and VDDQ tied together.  
 (3) The DC bandwidth is limited to 200MHz.  
 (4) The AC peak noise on VREF may not allow VREF to deviate from VREF(DC) by more than ±1% VDD (for reference: approx. ±12mV)

**IDD Specification parameters Definition - 4GB (1 Rank x8)**

Parameter	Symbol	DDR4 2400 CL17	Unit
One bank ACTIVATE-PRECHARGE current	IDD0 <sup>1</sup>	274	mA
One bank ACTIVATE-PRECHARGE, wordline boost, IPP current	IPP0 <sup>1</sup>	16	mA
One Bank Active-Read-Precharge Current	IDD1 <sup>1</sup>	329	mA
Precharge Standby Current	IDD2N <sup>2</sup>	143	mA
Precharge standby ODT current	IDD2NT <sup>1</sup>	188	mA
Precharge Power-Down Current	IDD2P <sup>2</sup>	93	mA
Precharge Quiet Standby Current	IDD2Q <sup>2</sup>	131	mA
Active standby current	IDD3N <sup>2</sup>	255	mA
Active standby IPP current	IPP3N <sup>2</sup>	8	mA
Active Power-Down Current	IDD3P <sup>2</sup>	182	mA
Burst Read Current	IDD4R <sup>1</sup>	909	mA
Burst write current	IDD4W <sup>1</sup>	986	mA
Burst refresh current (1x REF)	IDD5B <sup>1</sup>	1639	mA
Burst refresh IPP current (1x REF)	IPP5B <sup>1</sup>	286	mA
Self refresh current: Normal temperature range (0–85°C)	IDD6N <sup>2</sup>	86	mA
Self refresh current: Extended temperature range (0–95°C)	IDD6E <sup>2</sup>	109	mA
Bank interleave read current	IDD7 <sup>1</sup>	1159	mA
Bank interleave read IPP current	IPP7 <sup>1</sup>	87	mA
Maximum power-down current	IDD8 <sup>2</sup>	34	mA

Note: 1. One module rank in the active IDD/PP, the other rank in IDD2P/PP3N.  
2. All ranks in this IDD/PP condition.  
3. IDD current measure method and detail patterns are described on DDR4 component datasheet. Only for reference.

■ **Timing Parameters & Specifications**

Speed		DDR4-1866		DDR4-2133		DDR4-2400		Units	NOTE
Parameter	Symbol	MIN	MAX	MIN	MAX	MIN	MAX		
<b>Clock Timing</b>									
Minimum Clock Cycle Time (DLL off mode)	tCK (DLL_OFF)	8	-	8	-	8	20	ns	22
Average Clock Period	tCK(avg)	1.071	<1.25	0.938	<1.071	0.833	<0.938	ps	35,36
Average high pulse width	tCH(avg)	0.48	0.52	0.48	0.52	0.48	0.52	tCK(avg)	
Average low pulse width	tCL(avg)	0.48	0.52	0.48	0.52	0.48	0.52	tCK(avg)	
Absolute Clock Period	tCK(abs)	tCK(avg)min + tJIT(per)min_tot	tCK(avg)max + tJIT(per)max_tot	tCK(avg)min + tJIT(per)min_tot	tCK(avg)max + tJIT(per)max_tot	tCK(avg)min + tJIT(per)min_tot	tCK(avg)max + tJIT(per)max_tot	tCK(avg)	
Absolute clock HIGH pulse width	tCH(abs)	0.45	-	0.45	-	0.45	-	tCK(avg)	23
Absolute clock LOW pulse width	tCL(abs)	0.45	-	0.45	-	0.45	-	tCK(avg)	24
Clock Period Jitter- total	JIT(per)_tot	-54	54	-0.1	0.1	-42	42	ps	23
Clock Period Jitter- deterministic	JIT(per)_dj	-27	27	TBD	TBD	-21	21	ps	26
Clock Period Jitter during DLL locking period	tJIT(per, lck)	-43	43	TBD	TBD	-33	33	ps	
Cycle to Cycle Period Jitter	tJIT(cc)_total		107		94		83	ps	25
Cycle to Cycle Period Jitter deterministic	tJIT(cc)_dj		54		47		42	ps	26
Cycle to Cycle Period Jitter during DLL locking period	tJIT(cc, lck)		86		75		67	ps	
Duty Cycle Jitter	tJIT(duty)	TBD	TBD	TBD	TBD	TBD	TBD	ps	
Cumulative error across 2 cycles	tERR(2per)	-79	79	-69	69	-61	61	ps	
Cumulative error across 3 cycles	tERR(3per)	-94	94	-82	82	-73	73	ps	
Cumulative error across 4 cycles	tERR(4per)	-104	104	-91	91	-81	81	ps	
Cumulative error across 5 cycles	tERR(5per)	-112	112	-98	98	-87	87	ps	
Cumulative error across 6 cycles	tERR(6per)	-119	119	-104	104	-92	92	ps	
Cumulative error across 7 cycles	tERR(7per)	-124	124	-109	109	-97	97	ps	
Cumulative error across 8 cycles	tERR(8per)	-129	129	-113	113	-101	101	ps	
Cumulative error across 9 cycles	tERR(9per)	-134	134	-117	117	-104	104	ps	
Cumulative error across 10 cycles	tERR(10per)	-137	137	-120	120	-107	107	ps	
Cumulative error across 11 cycles	tERR(11per)	-141	141	-123	123	-110	110	ps	
Cumulative error across 12 cycles	tERR(12per)	-144	144	-126	126	-112	112	ps	
Cumulative error across 13 cycles	tERR(13per)	-147	147	-129	129	-114	114	ps	
Cumulative error across 14 cycles	tERR(14per)	-150	150	-131	131	-116	116	ps	
Cumulative error across 15 cycles	tERR(15per)	-152	152	-133	133	-118	118	ps	
Cumulative error across 16 cycles	tERR(16per)	-155	155	-135	135	-120	120	ps	
Cumulative error across 17 cycles	tERR(17per)	-157	157	-137	137	-122	122	ps	
Cumulative error across 18 cycles	tERR(18per)	-159	159	-139	139	-124	124	ps	
Cumulative error across n = 13, 14 ... 49, 50 cycles	tERR(nper)	$tERR(nper)min = ((1 + 0.68ln(n)) * tJIT(per)_total min)$ $tERR(nper)max = ((1 + 0.68ln(n)) * tJIT(per)_total max)$						ps	
Command and Address setup time to CK_t, CK_c referenced to Vih(ac) / Vil(ac) levels	tIS(base)	100	-	80	-	62	-	ps	
Command and Address setup time to CK_t, CK_c referenced to Vref levels	tIS(Vref)	200	-	180	-	162	-	ps	
Command and Address hold time to CK_t, CK_c referenced to Vih(dc) / Vil(dc) levels	tIH(base)	125	-	105	-	87	-	ps	
Command and Address hold time to CK_t, CK_c referenced to Vref levels	tIH(Vref)	200	-	180	-	162	-	ps	
Control and Address Input pulse width for each input	tIPW	525	-	460	-	410	-	ps	
<b>Command and Address Timing</b>									
CAS_n to CAS_n command delay for same bank group	tCCD_L	max(5 nCK, 6.250 ns)	-	max(5 nCK, 6.250 ns)	-	max(5 nCK, 6.250 ns)	-	nCK	34
CAS_n to CAS_n command delay for different bank group	tCCD_S	4	-	4	-	4	-	nCK	34
ACTIVATE to ACTIVATE Command delay to different bank group for 2KB page size	tRRD_S(2K)	Max(4nCK, 5.3ns)	-	Max(4nCK, 5.3ns)	-	Max(4nCK, 5.3ns)	-	nCK	34
ACTIVATE to ACTIVATE Command delay to different bank group for 1KB page size	tRRD_S(1K)	Max(4nCK, 4.2ns)	-	Max(4nCK, 3.7ns)	-	Max(4nCK, 3.3ns)	-	nCK	34
ACTIVATE to ACTIVATE Command delay to different bank group for 1/2KB page size	tRRD_S(1/2K)	Max(4nCK, 4.2ns)	-	Max(4nCK, 3.7ns)	-	Max(4nCK, 3.3ns)	-	nCK	34
ACTIVATE to ACTIVATE Command delay to same bank group for 2KB page size	tRRD_L(2K)	Max(4nCK, 6.4ns)	-	Max(4nCK, 6.4ns)	-	Max(4nCK, 6.4ns)	-	nCK	34
ACTIVATE to ACTIVATE Command delay to same bank group for 1KB page size	tRRD_L(1K)	Max(4nCK, 5.3ns)	-	Max(4nCK, 5.3ns)	-	Max(4nCK, 4.9ns)	-	nCK	34
ACTIVATE to ACTIVATE Command delay to same bank group for 1/2KB page size	tRRD_L(1/2K)	Max(4nCK, 5.3ns)	-	Max(4nCK, 5.3ns)	-	Max(4nCK, 4.9ns)	-	nCK	34
Four activate window for 2KB page size	tFAW_2K	Max(28nCK, 3 0ns)	-	Max(28nCK, 3 0ns)	-	Max(28nCK, 3 0ns)	-	ns	34
Four activate window for 1KB page size	tFAW_1K	Max(20nCK, 2 3ns)	-	Max(20nCK, 2 1ns)	-	Max(20nCK, 2 1ns)	-	ns	34
Four activate window for 1/2KB page size	tFAW_1/2K	Max(16nCK, 1 7ns)	-	Max(16nCK, 1 5ns)	-	Max(16nCK, 1 3ns)	-	ns	34
Delay from start of internal write transaction to internal read command for different bank group	tWTR_S	max(2nCK, 2.5ns)	-	Max(28nCK, 30ns)	-	max(2nCK, 2.5ns)	-		1,2,e, 34
Delay from start of internal write transaction to internal read command for same bank group	tWTR_L	max(4nCK, 7.5ns)	-	Max(20nCK, 21ns)	-	max(4nCK, 7.5ns)	-		1,34
Internal READ Command to PRECHARGE Command delay	tRTP	max(4nCK, 7.5ns)	-	Max(16nCK, 13ns)	-	max(4nCK, 7.5ns)	-		
WRITE recovery time	tWR	15	-	15	-	15	-	ns	1



Speed	Parameter	Symbol	DDR4-1866		DDR4-2133		DDR4-2400		Units	NOTE
			MIN	MAX	MIN	MAX	MIN	MAX		
	Write recovery time when CRC and DM are enabled	tWR_CRC_DM	tWR+max (5nCK,3.75ns)	-	tWR+max (5nCK,3.75ns)	-	tWR+max (5nCK,3.75ns)	-	ns	1,28
	delay from start of internal write transaction to internal read command for different bank group with both CRC and DM enabled	tWTR_S_C RC_DM	tWTR_S+max (5nCK,3.75ns)	-	tWTR_S+max (5nCK,3.75ns)	-	tWTR_S+max (5nCK,3.75ns)	-	ns	2, 29,34
	delay from start of internal write transaction to internal read command for same bank group with both CRC and DM enabled	tWTR_L_C RC_DM	tWTR_L+max (5nCK,3.75ns)	-	tWTR_L+max (5nCK,3.75ns)	-	tWTR_L+max (5nCK,3.75ns)	-	ns	3,30,34
	DLL locking time	tDLLK	597	-	768	-	768	-	nCK	
	Mode Register Set command cycle time	tMRD	8	-	8	-	8	-	nCK	
	Mode Register Set command update delay	tMOD	max(24nCK,15ns)	-	max(24nCK,15ns)	-	max(24nCK,15ns)	-	nCK	
	Multi-Purpose Register Recovery Time	tMPRR	1	-	1	-	1	-	nCK	33
	Multi Purpose Register Write Recovery Time	tWR_MPR	tMOD (min) + AL + PL	-	tMOD (min) + AL + PL	-	tMOD (min) + AL + PL	-	nCK	
	Auto precharge write recovery + precharge time	tDAL(min)	Programmed WR + roundup ( tRP / tCK(avg))						nCK	
	DQ0 or DQ0 driven to 0 set-up time to first DQS rising edge	tPDA_S	0.5	-	0.5	-	0.5	-	UI	45,47
	DQ0 or DQ0 driven to 0 hold time from last DQS fall-ing edge	tPDA_H	0.5	-	0.5	-	0.5	-	UI	45,47
<b>CS_n to Command Address Latency</b>										
	CS_n to Command Address Latency	tCAL	4	-	4	-	5	-	nCK	
<b>DRAM Data Timing</b>										
	DQS_t,DQS_c to DQ skew, per group, per access	tDQSQ	-	0.16	-	0.16	-	0.16	tCK(avg)/2	13,18
	DQ output hold time from DQS_t,DQS_c	tQH	0.76	-	0.76	-	0.76	-	tCK(avg)/2	13,17,18
	Data Valid Window per device: tQH - tDQSQ for a device	tDVWd	0.63	-	0.64	-	0.64	-	UI	16,17,18
	Data Valid Window per device, per pin: tQH - tDQSQ each device' s output	tDVWp	0.66	-	0.69	-	0.72	-	UI	16,17,18
<b>Data Strobe Timing</b>										
	DQS_t, DQS_c differential READ Preamble	tRPRE	0.9	NOTE44	0.9	NOTE44	0.9	NOTE44	tCK	40
	DQS_t, DQS_c differential READ Postamble	tRPST	0.33	TBD	0.33	TBD	0.33	TBD	tCK	41
	DQS_t,DQS_c differential output high time	tQSH	0.4	-	0.4	-	0.4	-	tCK	
	DQS_t,DQS_c differential output low time	tQSL	0.4	-	0.4	-	0.4	-	tCK	21
	DQS_t, DQS_c differential WRITE Preamble	tWPRE	0.9	-	0.9	-	0.9	-	tCK	20
	DQS_t, DQS_c differential WRITE Postamble	tWPST	0.33	TBD	0.33	TBD	0.33	TBD	tCK	42
	DQS_t and DQS_c low-impedance time (Referenced from RL-1)	tLZ(DQS)	-390	195	-360	180	-300	150	tCK	43
	DQS_t and DQS_c high-impedance time (Referenced from RL+BL/2)	tHZ(DQS)	-	195	-	180	-	150	tCK	
	DQS_t, DQS_c differential input low pulse width	tDQSL	0.46	0.54	0.46	0.54	0.46	0.54	ps	
	DQS_t, DQS_c differential input high pulse width	tDQSH	0.46	0.54	0.46	0.54	0.46	0.54	ps	
	DQS_t, DQS_c rising edge to CK_t, CK_c rising edge (1 clock preamble)	tDQSS	-0.27	0.27	-0.27	0.27	-0.27	0.27	tCK	
	DQS_t, DQS_c falling edge setup time to CK_t, CK_c rising edge	tDSS	0.18	-	0.18	-	0.18	-	tCK	
	DQS_t, DQS_c falling edge hold time from CK_t, CK_c rising edge	tDSH	0.18	-	0.18	-	0.18	-	tCK	
	DQS_t, DQS_c rising edge output timing locatino from rising CK_t, CK_c with DLL On mode	tDQSCK (DLL On)	-195	195	-180	180	-175	175	ps	37,38,39
	DQS_t, DQS_c rising edge output variance window per DRAM	tDQSCKI (DLL On)	-	330	-	310	-	290	ps	37,38,39
<b>MPSM Timing</b>										
	Command path disable delay upon MPSM entry	tMPED	tMOD(min) + tCPDED(min)	-	tMOD(min) + tCPDED(min)	-	tMOD(min) + tCPDED(min)	-	nCK	
	Valid clock requirement after MPSM entry	tCKMPE	tMOD(min) + tCPDED(min)	-	tMOD(min) + tCPDED(min)	-	tMOD(min) + tCPDED(min)	-	nCK	
	Valid clock requirement before MPSM exit	tCKMPX	tCKSRX(min)	-	tCKSRX(min)	-	tCKSRX(min)	-	nCK	
	Exit MPSM to commands not requiring a locked DLL	tXMP	txs(imin)	-	txs(imin)	-	txs(imin)	-	nCK	
	Exit MPSM to commands requiring a locked DLL	tXMPDLL	tXMP(min) + tXSDDL(min)	-	tXMP(min) + tXSDDL(min)	-	tXMP(min) + tXSDDL(min)	-	nCK	
	CS setup time to CKE	tMPX_S	tISmin + tIHmin	-	tISmin + tIHmin	-	tISmin + tIHmin	-	nCK	
<b>Calibration Timing</b>										
	Power-up and RESET calibration time	tZQinit	1024	-	1024	-	1024	-	nCK	
	Normal operation Full calibration time	tZQoper	512	-	512	-	512	-	nCK	
	Normal operation Short calibration time	tZQCS	128	-	128	-	128	-	nCK	
<b>Reset/Self Refresh Timing</b>										
	Exit Reset from CKE HIGH to a valid command	tXPR	max (5nCK,tRFC(min)+10ns)	-	max (5nCK,tRFC(min)+10ns)	-	max (5nCK,tRFC(min)+10ns)	-	nCK	
	Exit Self Refresh to commands not requiring a locked DLL	tXS	tRFC(min)+10ns	-	tRFC(min)+10ns	-	tRFC(min)+10ns	-	nCK	
	SRX to commands not requiring a locked DLL in Self Refresh ABORT	tXS_ABORT(min)	tRFC4(min)+10ns	-	tRFC4(min)+10ns	-	tRFC4(min)+10ns	-	nCK	
	Exit Self Refresh to ZQCL,ZQCS and MRS (CL,CWL,WR,RTP and Gear Down)	tXS_FAST (min)	tRFC4(min)+10ns	-	tRFC4(min)+10ns	-	tRFC4(min)+10ns	-	nCK	

Speed	Parameter	Symbol	DDR4-1866		DDR4-2133		DDR4-2400		Units	NOTE
			MIN	MAX	MIN	MAX	MIN	MAX		
	Exit Self Refresh to commands requiring a locked DLL	tXSDLL	tDLLK(min)	-	tDLLK(min)	-	tDLLK(min)	-		
	Minimum CKE low width for Self refresh entry to exit timing	tCKESR	tCKE(min)+1nCK	-	tCKE(min)+1nCK	-	tCKE(min)+1nCK	-		
	Minimum CKE low width for Self refresh entry to exit timing with CA Parity enabled	tCKESR_PAR	tCKE(min)+1nCK+PL	-	tCKE(min)+1nCK+PL	-	tCKE(min)+1nCK+PL	-		
	Valid Clock Requirement after Self Refresh Entry (SRE) or Power-Down Entry (PDE)	tCKSRE	max(5nCK,10ns)	-	max(5nCK,10ns)	-	max(5nCK,10ns)	-		
	Valid Clock Requirement after Self Refresh Entry (SRE) or Power-Down when CA Parity is enabled	tCKSRE_PAR	max(5nCK,10ns)+PL	-	max(5nCK,10ns)+PL	-	max(5nCK,10ns)+PL	-		
	Valid Clock Requirement before Self Refresh Exit (SRX) or Power-Down Exit (PDX) or Reset Exit	tCKSRX	max(5nCK,10ns)	-	max(5nCK,10ns)	-	max(5nCK,10ns)	-		
<b>Power Down Timing</b>										
	Exit Power Down with DLL on to any valid command; Exit Precharge Power Down with DLL frozen to commands not requiring a locked DLL	tXP	max(4nCK,6ns)	-	max(4nCK,6ns)	-	max(4nCK,6ns)	-		
	CKE minimum pulse width	tCKE	max(3nCK, 5ns)	-	max(3nCK, 5ns)	-	max(3nCK, 5ns)	-	nCK	31,32
	Command pass disable delay	tCPDED	4	-	4	-	4	-		
	Power Down Entry to Exit Timing	tPD	tCKE(min)	9*tREFI	tCKE(min)	9*tREFI	tCKE(min)	9*tREFI		6
	Timing of ACT command to Power Down entry	tACTPDEN	1	-	2	-	2	-	nCK	7
	Timing of PRE or PREA command to Power Down entry	tPRPDEN	1	-	2	-	2	-	nCK	7
	Timing of RD/RDA command to Power Down entry	tRDPDEN	RL+4+1	-	RL+4+1	-	RL+4+1	-	nCK	
	Timing of WR command to Power Down entry (BL8OTF, BL8MRS, BC4OTF)	tWRPDEN	WL+4+(tWR/tCK)(avg)	-	WL+4+(tWR/tCK)(avg)	-	WL+4+(tWR/tCK)(avg)	-	nCK	4
	Timing of WRA command to Power Down entry (BL8OTF, BL8MRS, BC4OTF)	tWRAPDEN	WL+4+WR+1	-	WL+4+WR+1	-	WL+4+WR+1	-	nCK	5
	Timing of WR command to Power Down entry (BC4MRS)	tWRPBC4DEN	WL+2+(tWR/tCK)(avg)	-	WL+2+(tWR/tCK)(avg)	-	WL+2+(tWR/tCK)(avg)	-	nCK	4
	Timing of WRA command to Power Down entry (BC4MRS)	tWRAPBC4DEN	WL+2+WR+1	-	WL+2+WR+1	-	WL+2+WR+1	-	nCK	5
	Timing of REF command to Power Down entry	tREFPDEN	1	-	2	-	2	-	nCK	7
	Timing of MRS command to Power Down entry	tMRSPDEN	tMOD(min)	-	tMOD(min)	-	tMOD(min)	-		
<b>PDA Timing</b>										
	Mode Register Set command cycle time in PDA mode	tMRD_PDA	max(16nCK,10ns)		max(16nCK,10ns)		max(16nCK,10ns)			
	Mode Register Set command update delay in PDA mode	tMOD_PDA		tMOD		tMOD		tMOD		
<b>ODT Timing</b>										
	Asynchronous RTT turn-on delay (Power-Down with DLL frozen)	tAONAS	1.0	9.0	1.0	9.0	1.0	9.0	ns	
	Asynchronous RTT turn-off delay (Power-Down with DLL frozen)	tAOFAS	1.0	9.0	1.0	9.0	1.0	9.0	ns	
	RTT dynamic change skew	tADC	0.3	0.7	0.3	0.7	0.3	0.7	tCK(avg)	
<b>Write Leveling Timing</b>										
	First DQS <sub>t</sub> /DQS <sub>n</sub> rising edge after write leveling mode is programmed	tWLMRD	40	-	40	-	40	-	nCK	12
	DQS <sub>t</sub> /DQS <sub>n</sub> delay after write leveling mode is programmed	tWLDQSEN	25	-	25	-	25	-	nCK	12
	Write leveling setup time from rising CK <sub>t</sub> , CK <sub>c</sub> crossing to rising DQS <sub>t</sub> /DQS <sub>n</sub> crossing	tWLS	0.13	-	0.13	-	0.13	-	tCK(avg)	
	Write leveling hold time from rising DQS <sub>t</sub> /DQS <sub>n</sub> crossing to rising CK <sub>t</sub> , CK <sub>c</sub> crossing	tWLH	0.13	-	0.13	-	0.13	-	tCK(avg)	
	Write leveling output delay	tWLO	0	9.5	0	9.5	0	9.5	ns	
	Write leveling output error	tWLOE							ns	
<b>CA Parity Timing</b>										
	Commands not guaranteed to be executed during this time	tPAR_UNKNOWN	-	Max(2nCK,3ns)	-	Max(2nCK,3ns)	-	Max(2nCK,3ns)		
	Delay from errant command to ALERT <sub>n</sub> assertion	tPAR_ALERT_ON	-	PL+6ns	-	PL+6ns	-	PL+6ns		
	Pulse width of ALERT <sub>n</sub> signal when asserted	tPAR_ALERT_PW	56	112	64	128	72	144	nCK	
	Time from when Alert is asserted till controller must start providing DES commands in Persistent CA parity mode	tPAR_ALERT_RSP	-	50	-	57	-	64	nCK	
	Parity Latency	PL		4		4		5	nCK	
<b>CRC Error Reporting</b>										
	CRC error to ALERT <sub>n</sub> latency	tCRC_ALERT	3	13	3	13	3	13	ns	
	CRC ALERT <sub>n</sub> pulse width	CRC_ALERT_PW	6	10	6	10	6	10	nCK	
<b>tREFI</b>										
tRFC1 (min)	2Gb	160	-	160	-	160	-	160	ns	
	4Gb	260	-	260	-	260	-	260	ns	
	8Gb	350	-	350	-	350	-	350	ns	
	16Gb	TBD	-	TBD	-	TBD	-	TBD	ns	
tRFC2 (min)	2Gb	110	-	110	-	110	-	110	ns	
	4Gb	160	-	160	-	160	-	160	ns	
	8Gb	260	-	260	-	260	-	260	ns	
	16Gb	TBD	-	TBD	-	TBD	-	TBD	ns	
tRFC4 (min)	2Gb	90	-	90	-	90	-	90	ns	
	4Gb	110	-	110	-	110	-	110	ns	
	8Gb	160	-	160	-	160	-	160	ns	
	16Gb	TBD	-	TBD	-	TBD	-	TBD	ns	

**SERIAL PRESENCE DETECT SPECIFICATION (AQD-SD4U4GE24-HG Serial Presence Detect)**

Byte	Function Described	Function	HEX Value
0	Number of Bytes Used / Number of Bytes in SPD Device / CRC Coverage	SPD Total: 512Bytes, SPD Used : 384Bytes	23
1	SPD Revision	Version 1.1	11
2	Key Byte / DRAM Device Type	DDR4 SDRAM	0C
3	Key Byte / Module Type	72b-SO-UDIMM	09
4	SDRAM Density and Banks	4 bank group / 4 bank	84
5	SDRAM Addressing	Row : 15	19
6	SDRAM Package Type	Column : 10	00
7	SDRAM Optional Features	Mono / Not specified	00
8	SDRAM Thermal and Refresh Options	Unlimited MAC	08
9	Other SDRAM Optional Features	-	00
10	Reserved	Post package repair supported	40
11	Module Nominal Voltage, VDD	-	00
12	Module Organization	1.2v	03
13	Module Memory Bus Width	1Rank	01
14	Module Thermal Sensor	x8	0B
15-16	Reserved	8bit ECC	84bits
17	Timebases	Thermal Sensor on module	80
18	SDRAM Minimum Cycle Time (tCKAVGmin)	-	00
19	SDRAM Maximum Cycle Time (tCKAVGmax)	MTB: 125ps	00
20	CAS Latencies Supported, First Byte	FTB: 1ps	07
21	CAS Latencies Supported, Second Byte	0.833 ns	0D
22	CAS Latencies Supported, Third Byte	1.6 ns	F8
23	CAS Latencies Supported, Fourth Byte	CL 10,11,12,13,14	0F
24	Minimum CAS Latency Time(tAAmin)	CL 15,16,17,18	00
25	Minimum RAS to CAS Delay Time (tRCDmin)	-	00
26	Minimum Row Precharge Delay Time (tRPmin)	13.75 ns	6E
27	Upper Nibbles for tRASmin and tRCmin	13.75 ns	6E
28	Minimum Active to Precharge Delay Time (tRASmin), Least Significant Byte	13.75 ns	6E
29	Minimum Active to Active/Refresh Delay Time (tRCmin), Least Significant Byte	45.75 ns	6E
30	Minimum Refresh Recovery Delay Time (tRFC1min), Least Significant Byte	260 ns	20
31	Minimum Refresh Recovery Delay Time (tRFC1min), Most Significant Byte	160 ns	08
32	Minimum Refresh Recovery Delay Time (tRFC2min), Least Significant Byte	110 ns	00
33	Minimum Refresh Recovery Delay Time (tRFC2min), Most Significant Byte	21 ns	05
34	Minimum Refresh Recovery Delay Time (tRFC4min), Least Significant Byte	-	70
35	Minimum Refresh Recovery Delay Time (tRFC4min), Most Significant Byte	-	03
36	Minimum Four Activate Window Time (tFAWmin), Most Significant Nibble	-	00
37	Minimum Four Activate Window Time (tFAWmin), Least Significant Byte	-	A8
38	Minimum Activate to Activate Delay Time (tRRD_Smin), different bank group	3.3 ns	1B
39	Minimum Activate to Activate Delay Time (tRRD_Lmin), same bank group	4.9 ns	28
40	Minimum CAS to CAS Delay Time (tCCD_Lmin), same bank group	5 ns	28
41	Upper Nibble for tWRmin	15 ns	00
42	Minimum Write Recovery Time (tWRmin)	15 ns	78
43	Upper Nibbles for tWTRmin	2.5 ns	00
44	Minimum Write to Read Time (tWTR_Smin), different bank group	2.5 ns	14
45	Minimum Write to Read Time (tWTR_Lmin), same bank group	7.5 ns	3C
41-59	Reserved, Base Configuration Section	-	00
60	Connector to SDRAM Bit Mapping	DQ0, DQ1, DQ2, DQ3	0C
61	Connector to SDRAM Bit Mapping	DQ4, DQ5, DQ6, DQ7	2B
62	Connector to SDRAM Bit Mapping	DQ8, DQ9, DQ10, DQ11	2D
63	Connector to SDRAM Bit Mapping	DQ12, DQ13, DQ14, DQ15	04
64	Connector to SDRAM Bit Mapping	DQ16, DQ17, DQ18, DQ19	16
65	Connector to SDRAM Bit Mapping	DQ20, DQ21, DQ22, DQ23	35
66	Connector to SDRAM Bit Mapping	DQ24, DQ25, DQ26, DQ27	23
67	Connector to SDRAM Bit Mapping	DQ28, DQ29, DQ30, DQ31	0D
68	Connector to SDRAM Bit Mapping	CB0-3	36
69	Connector to SDRAM Bit Mapping	CB4-7	0C
70	Connector to SDRAM Bit Mapping	DQ32, DQ33, DQ34, DQ35	2C
71	Connector to SDRAM Bit Mapping	DQ36, DQ37, DQ38, DQ39	0B
72	Connector to SDRAM Bit Mapping	DQ40, DQ41, DQ42, DQ43	03
73	Connector to SDRAM Bit Mapping	DQ44, DQ45, DQ46, DQ47	24
74	Connector to SDRAM Bit Mapping	DQ48, DQ49, DQ50, DQ51	35
75	Connector to SDRAM Bit Mapping	DQ52, DQ53, DQ54, DQ55	0C
76	Connector to SDRAM Bit Mapping	DQ56, DQ57, DQ58, DQ59	03
77	Connector to SDRAM Bit Mapping	DQ60, DQ61, DQ62, DQ63	2D
78-116	Reserved, Base Configuration Section	-	00

Byte	Function Described	Function	HEX Value
117	Fine Offset for Minimum CAS to CAS Delay Time(tCCD_Lmin), same bank group	0ns	00
118	Fine Offset for Minimum Activate to Activate Delay Time(tRRD_Lmin), different bank group	-0.1ns	9C
119	Fine Offset for Minimum Activate to Activate Delay Time(tRRD_Smin), same bank group	-0.076 ns	B4
120	Fine Offset for Minimum Activate to Activate/Refresh Delay Time(tRCmin)	0ns	00
121	Fine Offset for Minimum Row Precharge Delay Time(tRPmin)	0ns	00
122	Fine Offset for Minimum RAS to CAS Delay Time(tRCDmin)	0ns	00
123	Fine Offset for Minimum CAS Latency Time(tAAmin)	0ns	00
124	Fine Offset for SDRAM Maximum Cycle Time(tCKAVGmax)	-0.025ns	E7
125	Fine Offset for SDRAM Minimum Cycle Time(tCKAVGmin)	-0.042ns	D6
126	Cyclical Redundancy Code for Base Configuration Section, LSB	CRC-CCITT(LOW)	6F
127	Cyclical Redundancy Code for Base Configuration Section, MSB	CRC-CCITT(HIGH)	7C
128	(Unbuffered): Raw Card Extension, Module Nominal Height	Revision 1      30.00 mm	0F
129	(Unbuffered): Module Maximum Thickness	-	11
130	(Unbuffered): Reference Raw Card Used	Raw Card D      Revision 1	23
131	(Unbuffered): Address Mapping from Edge Connector to DRAM	Standard	00
132-253	(Unbuffered): Reserved	-	00
254	(Unbuffered): CRC for Module Specific Section, Least Significant Byte	CRC-CCITT(LOW)	BE
255	(Unbuffered): CRC for Module Specific Section, Most Significant Byte	CRC-CCITT(HIGH)	A2
256-319	Hybrid Memory Architecture Specific Parameters		00
320	Module Manufacturer ID Code, LSB	ADATA	04
321	Module Manufacturer ID Code, MSB		CB
322	Module ID: Module Manufacturing Location	*Note: 1	-
323	Module ID: Module Manufacturing Date(Year)	*Note: 2	-
324	Module ID: Module Manufacturing Date(Week)	*Note: 3	-
325-328	Module ID : Module Serial Number	*Note: 4	-
329-348	Module Part Number	*Note: 5	-
349	Module Revision Code	-	00
350	SDRAM Manufacturer's JEDEC ID Code, LSB	Hynix	80
351	SDRAM Manufacturer's JEDEC ID Code, MSB		AD
352	DRAM Stepping	-	FF
353-381	Manufacturer's Specific Data	*Note: 6	-
382	Reserved		00
383	Reserved		00
384-511	End User Programmable	*Note: 7	-

- Note :
1. Byte 322 -- Manufacturing location by manufacturing location (00:Taiwan /01:China)
  2. Byte 323 -- Module manufacturing date by year (YY).
  3. Byte 324 -- Module manufacturing date by week (WW).
  4. Bytes 325~328 -- Module Serial Number.
  5. Bytes 329~348 -- Manufacturer Part Number by module part number , (Unused digits are coded as ASCII blanks (20h)).
  6. Bytes 353~381 -- These bytes are undefined and can be used for ADATA's own purpose. Digits are coded as 00h except the following:
    - 6-1. Bytes 353~367 -- Manufacturer's Specific Data by working order number.
    - 6-2. Bytes 368~381 -- Manufacturer's Specific Data by SPD naming number.
  7. Bytes 384~511 -- These bytes are undefined and can be used for ADATA's own purpose. Digits are coded as 00h except the following:
    - 7-1. Bytes 384 -- The byte is coded as ADh.