

22DCP Athlonix™

Ø 22 mm • Graphite-Copper commutation • 6.21 mNm

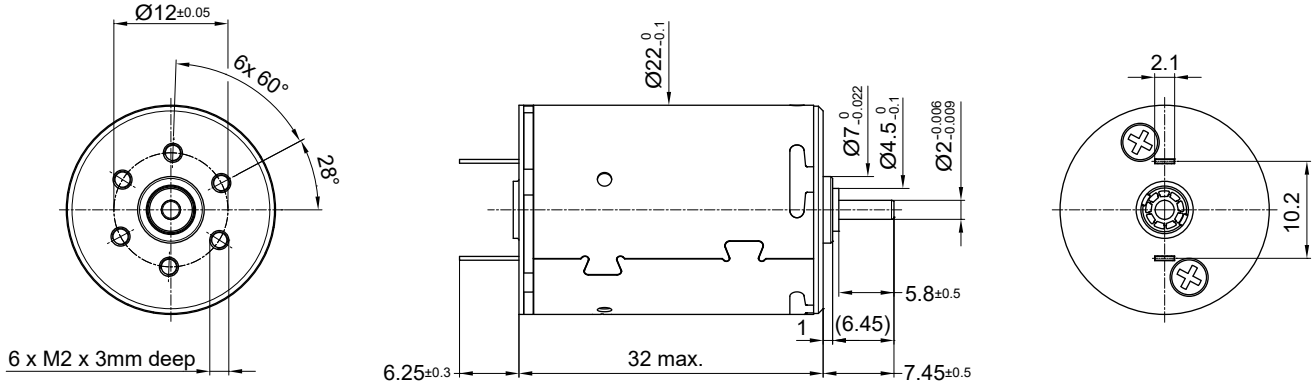

Dimensions in mm.

Electrical Data	Symbol	221P	216P	22DCP 32G1 213P	211P	210P	209P	Unit
1 Nominal Voltage	V	3	6	9	12	15	18	Volt
2 No-Load Speed	n_0	8094	9574	9874	9598	9600	9211	rpm
3 No-Load Current	I_0	132.6	77.4	53.0	38.7	30.9	24.8	mA
4 Terminal Resistance	R	0.9	2.2	4.3	8.0	12.3	18.8	Ω
5 Output Power	$P_{2\text{max}}$	2.2	3.7	4.1	3.9	4.0	3.8	W
6 Stall Torque	mNm	10.44 (1.48)	15.6 (2.21)	17.23 (2.45)	17.1 (2.43)	17.29 (2.45)	16.94 (2.4)	mNm (oz-in)
7 Efficiency	η_{max}	63	69	71	71	71	70	%
8 Max Continuous Speed	$n_{e \text{ max.}}$	10000	10000	10000	10000	10000	10000	rpm
9 Max Continuous Torque	$M_{e \text{ max.}}$	5.13 (0.73)	5.82 (0.83)	6.04 (0.86)	6.11 (0.87)	6.14 (0.87)	6.21 (0.88)	mNm (oz-in)
10 Max Continuous Current	$I_{e \text{ max.}}$	1.64	1.08	0.77	0.56	0.45	0.37	A
11 Back-EMF Constant	k_E	0.36	0.61	0.89	1.22	1.52	1.90	mV/rpm
12 Torque Constant	k_M	3.39	5.82	8.48	11.63	14.54	18.18	mNm/A
13 Motor Regulation	R/k^2	81.20	64.28	60.00	58.76	58.16	56.95	$10^3/\text{Nms}$
14 Friction Torque	T_F	0.45 (0.07)	0.45 (0.07)	0.45 (0.07)	0.45 (0.07)	0.45 (0.07)	0.45 (0.07)	mNm (oz-in)
15 Mechanical Time Constant	τ_m	38.97	30.70	28.44	27.50	27.12	26.89	ms
16 Rotor Inertia	J	4.80	4.78	4.74	4.68	4.66	4.72	g-cm ²

General Data				
17 Thermal Resistance (rotor/body)	R_{th1}/R_{th2}	6/22		$^\circ\text{C}/\text{W}$
18 Thermal Time Constant (rotor/stator)	t_{W1}/t_{W2}	9/550		S
19 Operating Temperature Range:	motor rotor	-30 $^\circ\text{C}$ to 85 $^\circ\text{C}$ (-22 $^\circ\text{F}$ to 185 $^\circ\text{F}$) 100 $^\circ\text{C}$ (212 $^\circ\text{F}$)		$^\circ\text{C}$ ($^\circ\text{F}$) $^\circ\text{C}$ ($^\circ\text{F}$)
20 Shaft Load Max.: (5 mm. from bearing)	-radial -axial	With sleeve bearings 1.5 (5.39) 100 (359.6)		N (oz) N (oz)
21 Shaft Play:	-radial -axial	0.03 (0.0012) 0.15 (0.0059)		mm (inch) mm (inch)
22 Weight	g	58 (2.05)		g (oz)
23 Commutation Segment	-	9		segment

*Also available with ball bearing

Execution Table

Gearbox	Single Shaft	MR2	E9
R22	4	5	6
K24	7	8	9
K27	1	2	3
R22HT	11	Upon Request	Upon Request

Note:
G1: standard commutation
G2: special commutation for double shaft version

► Motor shaft rotates CW when seen from motor front face when +ve and -ve supply is given to respective terminals.

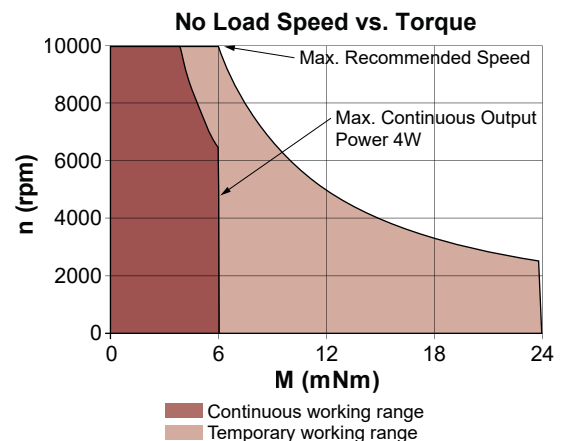

22DCP Athlonix™

Ø 22 mm • Graphite-Copper commutation • 6.21 mNm

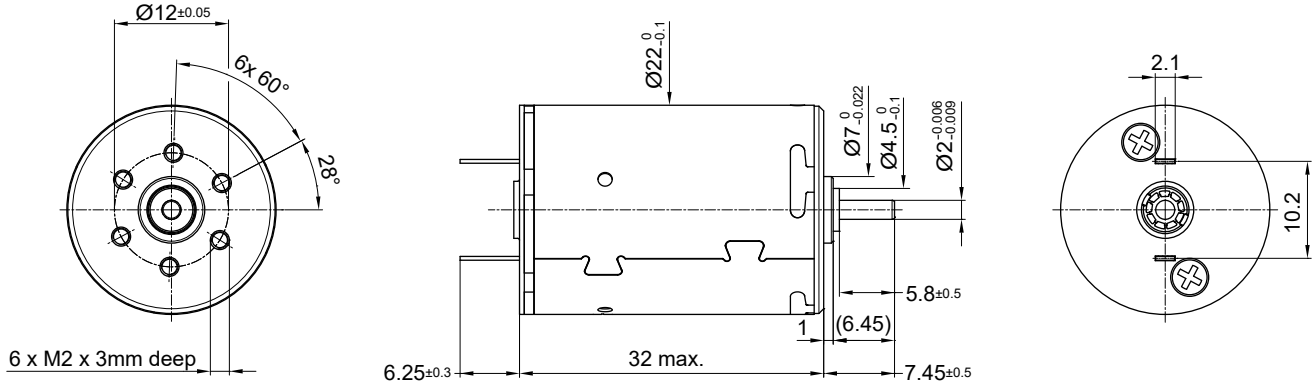

Dimensions in mm.

Electrical Data	Symbol	22DCP 32G1 *** .1					Unit
		212E	211E	210E	209E	208E	
1 Nominal Voltage	V	21	24	30	36	48	Volt
2 No-Load Speed	n_0	10,201	10,308	10,645	10,123	10,889	rpm
3 No-Load Current	I_0	23.5	20.8	17.2	13.6	11.0	mA
4 Terminal Resistance	R	23.6	30.6	46.3	71.9	112.8	Ω
5 Output Power	P_{2max}	4.0	4.1	4.2	3.9	4.3	W
6 Stall Torque	mNm	16.56 (2.35)	16.53 (2.35)	16.53 (2.35)	16.09 (2.28)	17 (2.41)	mNm (oz-in)
7 Efficiency	h_{max}	70	70	70	70	70	%
8 Max Continuous Speed	$n_{e max}$	10,000	10,000	10,000	10,000	10,000	rpm
9 Max Continuous Torque	$M_{e max}$	5.81 (0.83)	5.77 (0.82)	5.67 (0.81)	5.74 (0.82)	5.69 (0.81)	mNm (oz-in)
10 Max Continuous Current	$I_{e max}$	0.33	0.29	0.23	0.19	0.15	A
11 Back-EMF Constant	k_E	2.00	2.27	2.74	3.46	4.29	mV/rpm
12 Torque Constant	k_M	19.14	21.64	26.20	33.03	41.01	mNm/A
13 Motor Regulation	R/k^2	64.5	65.3	67.4	65.89	67.07	$10^3/Nms$
14 Friction Torque	T_F	0.45 (0.07)	0.45 (0.07)	0.45 (0.07)	0.45 (0.07)	0.45 (0.07)	mNm (oz-in)
15 Mechanical Time Constant	τ_m	30.3	30.2	30.1	30.1	30.0	ms
16 Rotor Inertia	J	4.70	4.63	4.47	4.56	4.48	g-cm ²

General Data				
17 Thermal Resistance (rotor/body)	R_{th1}/R_{th2}	6.22		$^\circ\text{C}/\text{W}$
18 Thermal Time Constant (rotor/stator)	t_{w1}/t_{w2}	9/550		S
19 Operating Temperature Range:	motor	-30°C to 85°C (-22°F to 185°F)		$^\circ\text{C}$ ($^\circ\text{F}$)
	rotor	100°C (212°F)		$^\circ\text{C}$ ($^\circ\text{F}$)
20 Shaft Load Max.: (5 mm. from bearing)		With sleeve bearings		
	-radial	1.5 (5.39)		N (oz)
	-axial	100 (359.6)		N (oz)
21 Shaft Play:	-radial	0.03 (0.0012)		mm (inch)
	-axial	0.15 (0.0059)		mm (inch)
22 Weight	g	58 (2.05)		g (oz)
23 Commutation Segment	-	9		segment

*Also available with ball bearing

Execution Table

Gearbox	Single Shaft	MR2	E9
R22	4	5	6
K24	7	8	9
K27	1	2	3
R22HT	11	Upon Request	Upon Request

Note:
G1: standard commutation
G2: special commutation for double shaft version

► Motor shaft rotates CW when seen from motor front face when +ve and -ve supply is given to respective terminals.

