

Using the TPS211xADRB EVM

User's Guide



Literature Number: SLUU409
February 2010

TPS211xADRB EVM, Power Multiplexer Evaluation Module

1 Introduction

The TPS211xA EVM is an evaluation module for the Texas Instruments TPS211xA family of two-input, one-output power multiplexers. These multiplexers enable seamless transition between two power supplies, each operating at 2.8 V-5.5 V and delivering up to 1 A. TPS211xA EVM-061 is used for TPS211xAPW packaged parts. The TPS211xA EVM-581 is used for TPS211xADRB packaged parts and described in this user's guide which contains the EVM schematics, board layout, list of materials and configuration materials.

The EVM has test points for convenient access to all critical node voltages, potentiometers for adjusting the current limit and the auto-switching voltage sense thresholds, headers for selecting the manual/auto-switching operating modes, and headers for selecting the output hold-up capacitance.

2 EVM Setup

This chapter describes the proper setup of the TPS211xAEVM for use indevice evaluations.

2.1 Setting Up the EVM

The user is encouraged to read the applicable TPS211xA data sheet before using the EVM.

The following test equipment is recommended:

- Storage oscilloscope
- Current probe
- Two adjustable power supplies, 0 V - 6 V @ 2-A
- Volt-Ohm meter
- A passive or active load

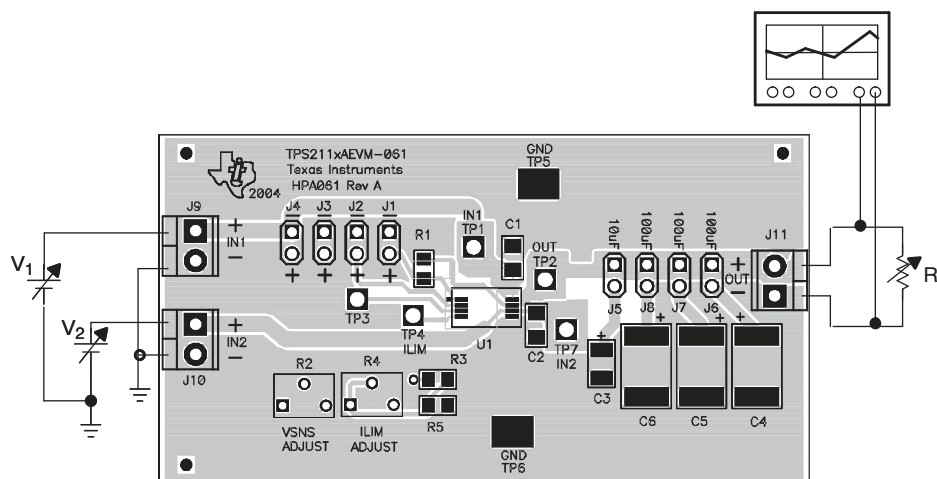

Figure 1. Basic EVM Setup

2.2 Current-Limit Adjustment

Potentiometer R4 controls the resistance RILIM that sets the TPS211xA current limit threshold. Adjusting R4 clockwise increases the current limit threshold by decreasing RILIM. The current limit threshold is $500/RILIM$ for the TPS2113A and TPS2115A.

To measure the resistance RILIM, connect an ohmmeter between test points TP4 and GND. The measurement should be made with the IN1 and IN2 supplies off. To ensure accurate in-circuit resistance measurements, the ohmmeter must apply no more than 0.5 V across the resistor.

2.3 Manual Switching Mode (TPS2115A Only)

Potentiometer R2 and header J4 do not affect the operation of the manual switching mode.

Some products like digital cameras and hand-held devices that receive power from an internal battery or from a docking station can take advantage of the manual-switching feature. The TPS2115A digital control input, D1, can directly sense the presence of the docking station and connect the load to the appropriate power source.

2.3.1 Configuring the TPS2115A for Manual Switching

To place the device into manual switching mode, short header J2. The logic level on the D1 pin determines which input is selected. On the EVM, header J3 controls the D1 pin. If J3 is left open, then D1 is internally pulled high and IN1 is selected. If J3 is shorted, then D1 is pulled low and IN2 is selected.

2.4 Automatic Switching Modes

All EVMs support Mode 1 automatic switching. Mode 2 automatic switching is supported by the TPS2113A EVM only.

2.4.1 Mode 1 Automatic Switching

OUT connects to the higher of IN1 and IN2 in Mode 1 automatic switching. Refer to Table 2-1 to configure the EVM for Mode 1 automatic switching.

Table 1. EVM Shorting Jumper Placement for Mode 1 Automatic Switching

EVM	DEVICE	HEADER			
		J1	J2	J3	J4
HPA581-001	TPS2113A	OUT	IN	OUT	OUT
HPA581-002	TPS2115A	OUT	OUT	IN	OUT

A manufacturer can provide a secondary battery pack option to extend the product run time with Mode 1 automatic switching. The TPS211xA cycles between the primary and secondary batteries until both batteries are drained.

2.4.2 Mode 2 Automatic Switching (TPS2113A Only)

In Mode 2 automatic switching, OUT connects to IN1 if the voltage at IN1 is sufficiently high; otherwise, OUT connects to the higher of IN1 and IN2. The threshold at which IN1 is selected corresponds to approximately 0.8 V at test point TP3. The corresponding value of the IN1 voltage depends upon the setting of potentiometer R2. Adjusting R2 clockwise increases the IN1 selection threshold voltage.

Table 2. EVM Shorting Jumper Placement for Mode 2 Automatic Switching

EVM	DEVICE	HEADER			
		J1	J2	J3	J4
HPA581-002		OUT	IN	OUT	IN

A manufacturer can provide a secondary battery pack option to extend the product run time with Mode 2 automatic switching. The TPS2110A-TPS2113A drains the primary battery at IN1 and automatically switches to the secondary battery at IN2.

2.5 Output Voltage Holdup

Headers J5-J8 select the output holdup capacitance.

The output voltage drops out for 60 ms (max) whenever the TPS211xA switches between the IN1 and IN2 supplies. Some capacitance at the TPS211xA output is necessary to prevent the output voltage from dropping too much during the supply switchover. Excessive voltage drop can cause a system to reset or lose data.

2.6 Switch Status

The switch status output can be monitored at the positive terminal of header J1. A switch status output equal to logic 1 corresponds to an IN2 switch that is on.

3 Schematic and List of Materials

This chapter provides the TPS211xAEVM schematic and list of materials.

3.1 EVM Configurations

Table 3. Available EVM Configurations

EVM DESIGNATOR	DEVICE	CURRENT-LIMIT ADJUSTMANT RANGE	SWITCH STATUS OUTPUT	SWITCHING MODE	
				AUTOMATIC	MANUAL
HPA581-001	TPS2113A	0.63 A to 1.25 A	Yes	Yes	No
HPA581-002	TPS2115A	0.63 A to 1.25 A	Yes	Yes	Yes

3.2 Schematic

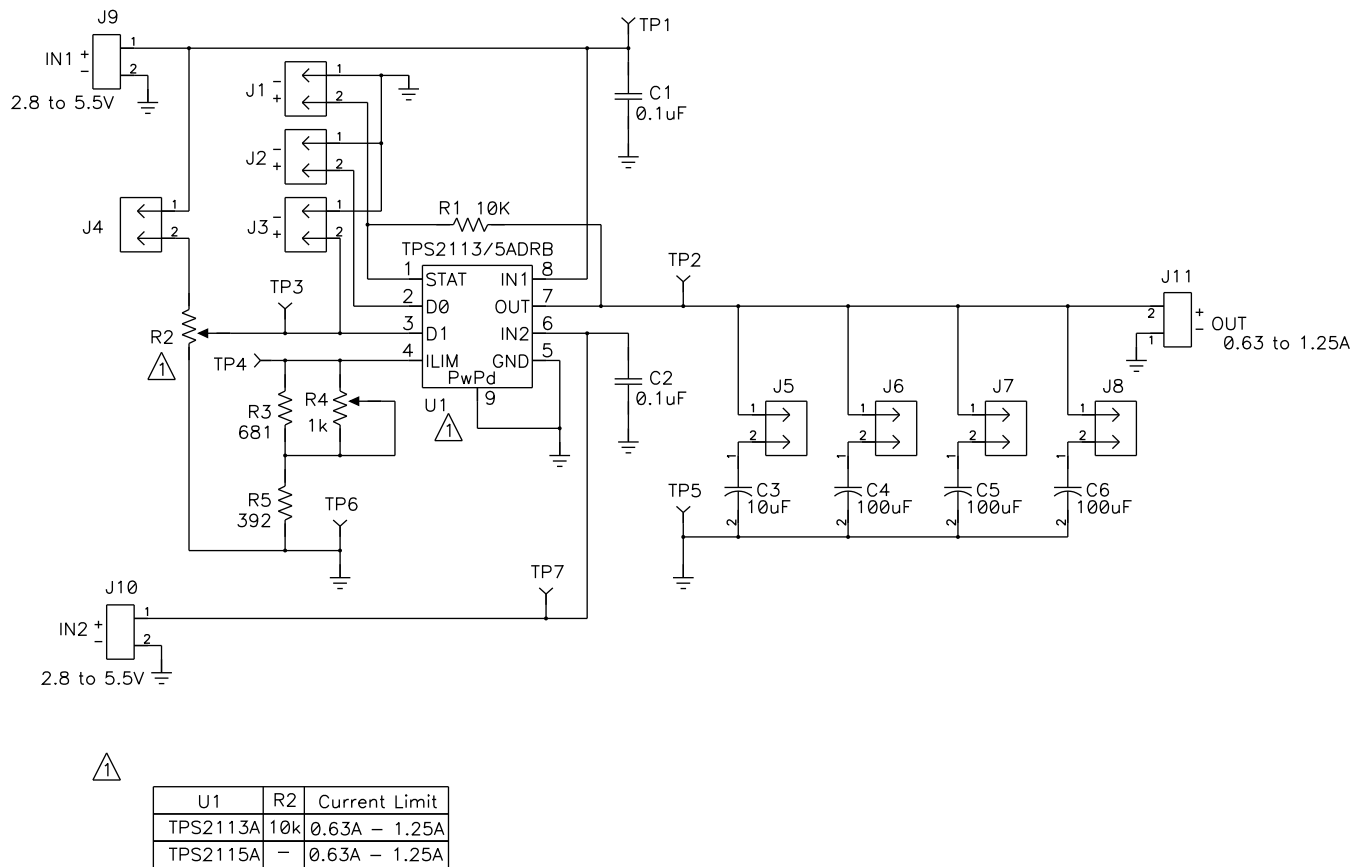

Figure 2. TPS211xAEVM Schematic

Table 4.

U1	R1	R2	R3	R5	CURRENT LIMIT
TPS2113A	10 kΩ	10 kΩ	681 Ω	392 Ω	0.63 A to 1.25 A
TPS2115A	10 kΩ	-	681 Ω	392 Ω	0.63 A to 1.25 A

3.3 List of Materials

Table 5. TPS2113A/5A List of Materials ⁽¹⁾⁽²⁾⁽³⁾⁽⁴⁾

-002	-001	RefDes	Description	PART NUMBER	MFR
2	2	C1, C2	Capacitor, ceramic, 0.1 μ F, 50 V, X&R, 10%, 1206	1206R104K9B20 D	Philips
1	1	C3	Capacitor, tantalum, 10 μ F, 10 V, 20%, 3528	293D106X0010B2 T	Vishay
3	3	C4, C5, C6	Capacitor, tantalum, 100 μ F, 10 V, 20%, 7343 (D)	293D107X0010D2 T	Vishay
8	8	J1, J2, J3, J4, J5, J6, J7, J8	Header, male 2 pin, 100-mil spacing, 0.100 inch x 2 inch	PEC02SAAN	Sullins
3	3	J9, J10, J11	Terminal block, 2 pin, 6 A, 3.5 mm, 0.27 inch x 0.25 inch	ED555/2DS	OST
1	1	R1	Resistor, chip, 10 k Ω , 1/10 W, 1%, 0805	ERJ-ENC1002	Panasonic
0	1	R2	Potentiometer, 10 k Ω , 0.25 W, 12 turn, top-adjust, 0.25 inch x 0.17 inch	3266W-1-103	Bourns
1	1	R3	Resistor, chip, 681 Ω , 1/10 W, 1%, 0805	STD	Vishay
1	1	R4	Potentiometer, 1 k Ω , 0.25 W 10% , 12 turn, top-adjust, 0.25 inch x 0.17 inch	3266W-1-102	Bourns
1	1	R5	Resistor, chip, 392 Ω , 1/10 W, 1%, 0805	STD	Vishay
5	5	TP1, TP2, TP3, TP4, TP7	Test point, white, 0.250 inch	5012	Keystone
2	2	TP5, TP6	Test point, SM, square, 0.185 inch x 0.135 inch	5016	Keystone
0	1	U1	Auto switching power mux, SON-8	TPS2114/5ADRB	TI
1	0	U1	Auto switching power mux, SON-8	TPS2114/5ADRB	TI

⁽¹⁾ These assemblies are ESD sensitive, ESD precautions shall be observed.

⁽²⁾ These assemblies must be clean and free from flux and all contaminants. Use of no clean flux is not acceptable.

⁽³⁾ These assemblies must comply with workmanship standards IPC-A-610 Class 2.

⁽⁴⁾ Ref designators marked with an asterisk (***) cannot be substituted. All other components can be substituted with equivalent MFG's components.

4 Board Layout

This chapter describes the TPS211xAEVM board layout and presents some component placement considerations.

4.1 Layout Considerations

The IN1, IN2, and OUT pins of the TPS211xA can carry up to 1 A, so traces to these pins should be of suitable length and width to minimize the voltage drop to the load. Locate the 0.1 mF bypass capacitors close to the IN1, IN2, and GND pins of the TPS211xA.

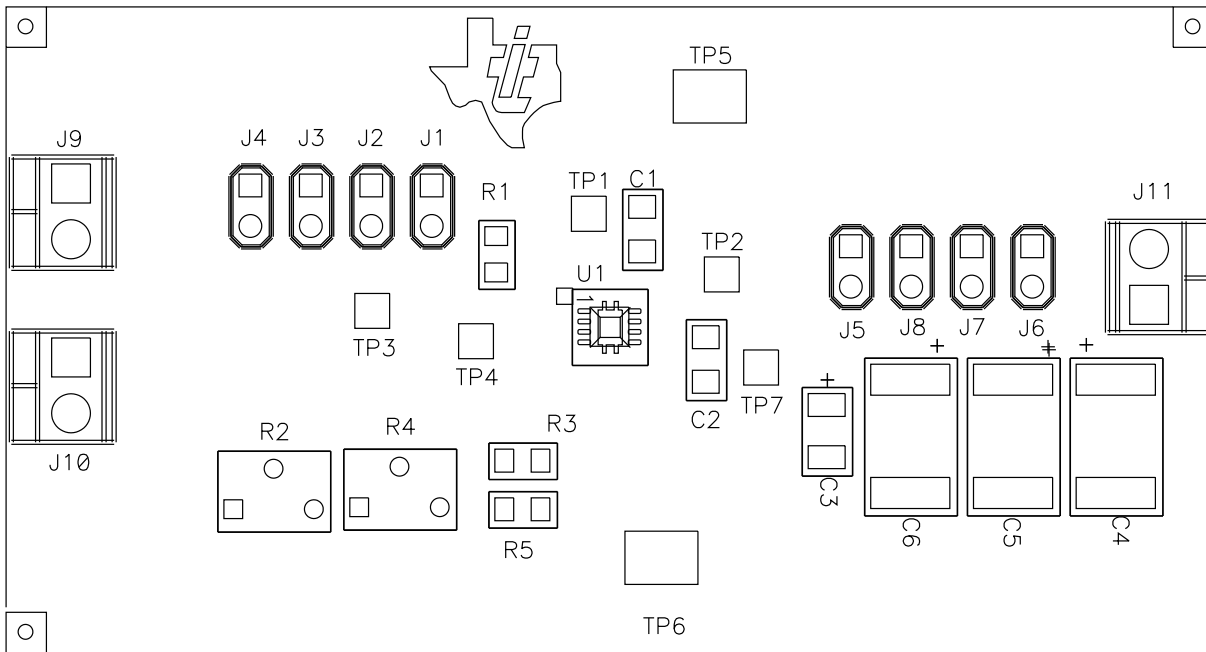

Figure 3. Top-Side Layout

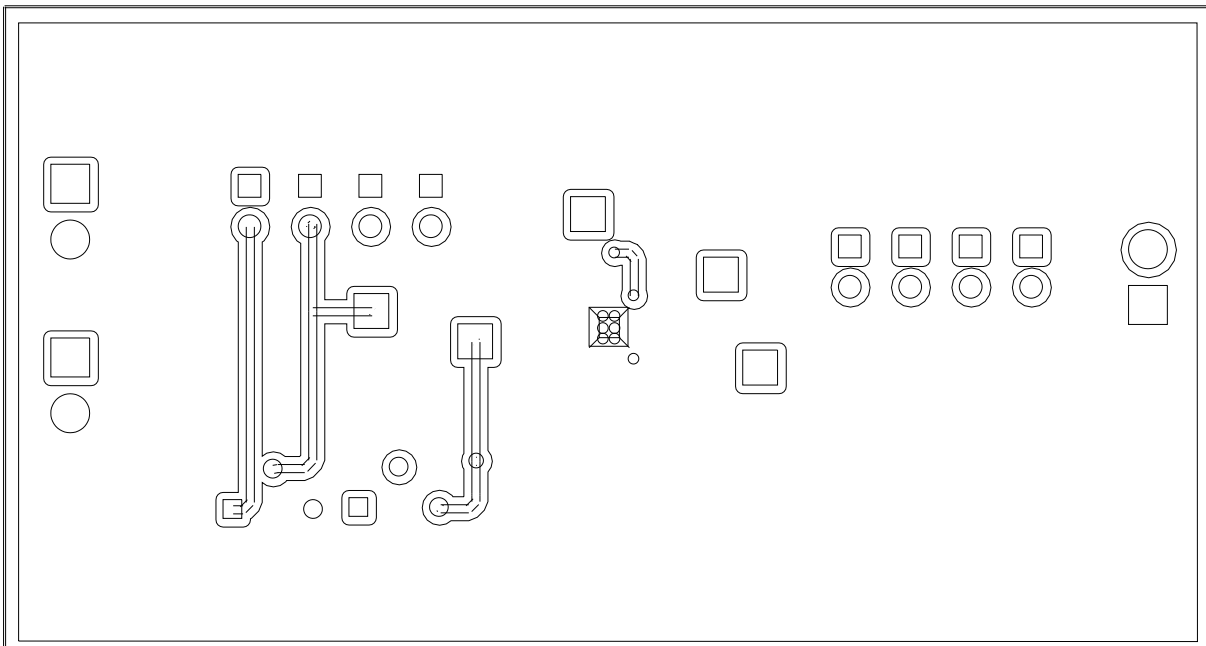

Figure 4. Bottom-Side Layout

IMPORTANT NOTICE

Texas Instruments Incorporated and its subsidiaries (TI) reserve the right to make corrections, modifications, enhancements, improvements, and other changes to its products and services at any time and to discontinue any product or service without notice. Customers should obtain the latest relevant information before placing orders and should verify that such information is current and complete. All products are sold subject to TI's terms and conditions of sale supplied at the time of order acknowledgment.

TI warrants performance of its hardware products to the specifications applicable at the time of sale in accordance with TI's standard warranty. Testing and other quality control techniques are used to the extent TI deems necessary to support this warranty. Except where mandated by government requirements, testing of all parameters of each product is not necessarily performed.

TI assumes no liability for applications assistance or customer product design. Customers are responsible for their products and applications using TI components. To minimize the risks associated with customer products and applications, customers should provide adequate design and operating safeguards.

TI does not warrant or represent that any license, either express or implied, is granted under any TI patent right, copyright, mask work right, or other TI intellectual property right relating to any combination, machine, or process in which TI products or services are used. Information published by TI regarding third-party products or services does not constitute a license from TI to use such products or services or a warranty or endorsement thereof. Use of such information may require a license from a third party under the patents or other intellectual property of the third party, or a license from TI under the patents or other intellectual property of TI.

Reproduction of TI information in TI data books or data sheets is permissible only if reproduction is without alteration and is accompanied by all associated warranties, conditions, limitations, and notices. Reproduction of this information with alteration is an unfair and deceptive business practice. TI is not responsible or liable for such altered documentation. Information of third parties may be subject to additional restrictions.

Resale of TI products or services with statements different from or beyond the parameters stated by TI for that product or service voids all express and any implied warranties for the associated TI product or service and is an unfair and deceptive business practice. TI is not responsible or liable for any such statements.

TI products are not authorized for use in safety-critical applications (such as life support) where a failure of the TI product would reasonably be expected to cause severe personal injury or death, unless officers of the parties have executed an agreement specifically governing such use. Buyers represent that they have all necessary expertise in the safety and regulatory ramifications of their applications, and acknowledge and agree that they are solely responsible for all legal, regulatory and safety-related requirements concerning their products and any use of TI products in such safety-critical applications, notwithstanding any applications-related information or support that may be provided by TI. Further, Buyers must fully indemnify TI and its representatives against any damages arising out of the use of TI products in such safety-critical applications.

TI products are neither designed nor intended for use in military/aerospace applications or environments unless the TI products are specifically designated by TI as military-grade or "enhanced plastic." Only products designated by TI as military-grade meet military specifications. Buyers acknowledge and agree that any such use of TI products which TI has not designated as military-grade is solely at the Buyer's risk, and that they are solely responsible for compliance with all legal and regulatory requirements in connection with such use.

TI products are neither designed nor intended for use in automotive applications or environments unless the specific TI products are designated by TI as compliant with ISO/TS 16949 requirements. Buyers acknowledge and agree that, if they use any non-designated products in automotive applications, TI will not be responsible for any failure to meet such requirements.

Following are URLs where you can obtain information on other Texas Instruments products and application solutions:

Products		Applications	
Amplifiers	amplifier.ti.com	Audio	www.ti.com/audio
Data Converters	dataconverter.ti.com	Automotive	www.ti.com/automotive
DLP® Products	www.dlp.com	Communications and Telecom	www.ti.com/communications
DSP	dsp.ti.com	Computers and Peripherals	www.ti.com/computers
Clocks and Timers	www.ti.com/clocks	Consumer Electronics	www.ti.com/consumer-apps
Interface	interface.ti.com	Energy	www.ti.com/energy
Logic	logic.ti.com	Industrial	www.ti.com/industrial
Power Mgmt	power.ti.com	Medical	www.ti.com/medical
Microcontrollers	microcontroller.ti.com	Security	www.ti.com/security
RFID	www.ti-rfid.com	Space, Avionics & Defense	www.ti.com/space-avionics-defense
RF/IF and ZigBee® Solutions	www.ti.com/lprf	Video and Imaging	www.ti.com/video
		Wireless	www.ti.com/wireless-apps