

INTERRUPTED WALL FOR POSITION SIZES 6 AND ABOVE

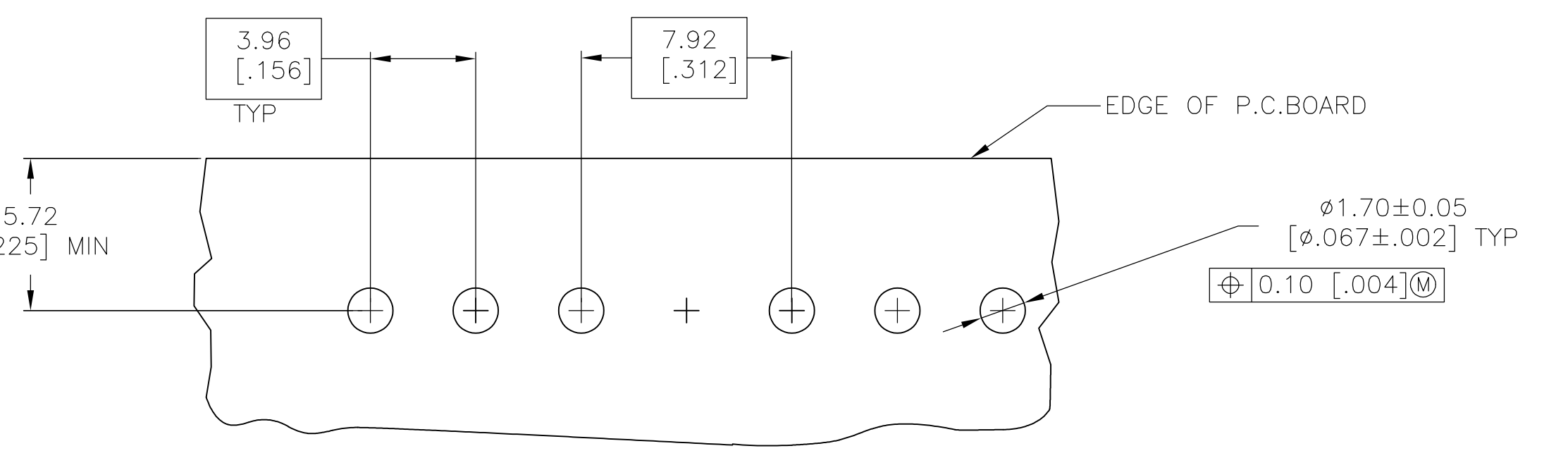
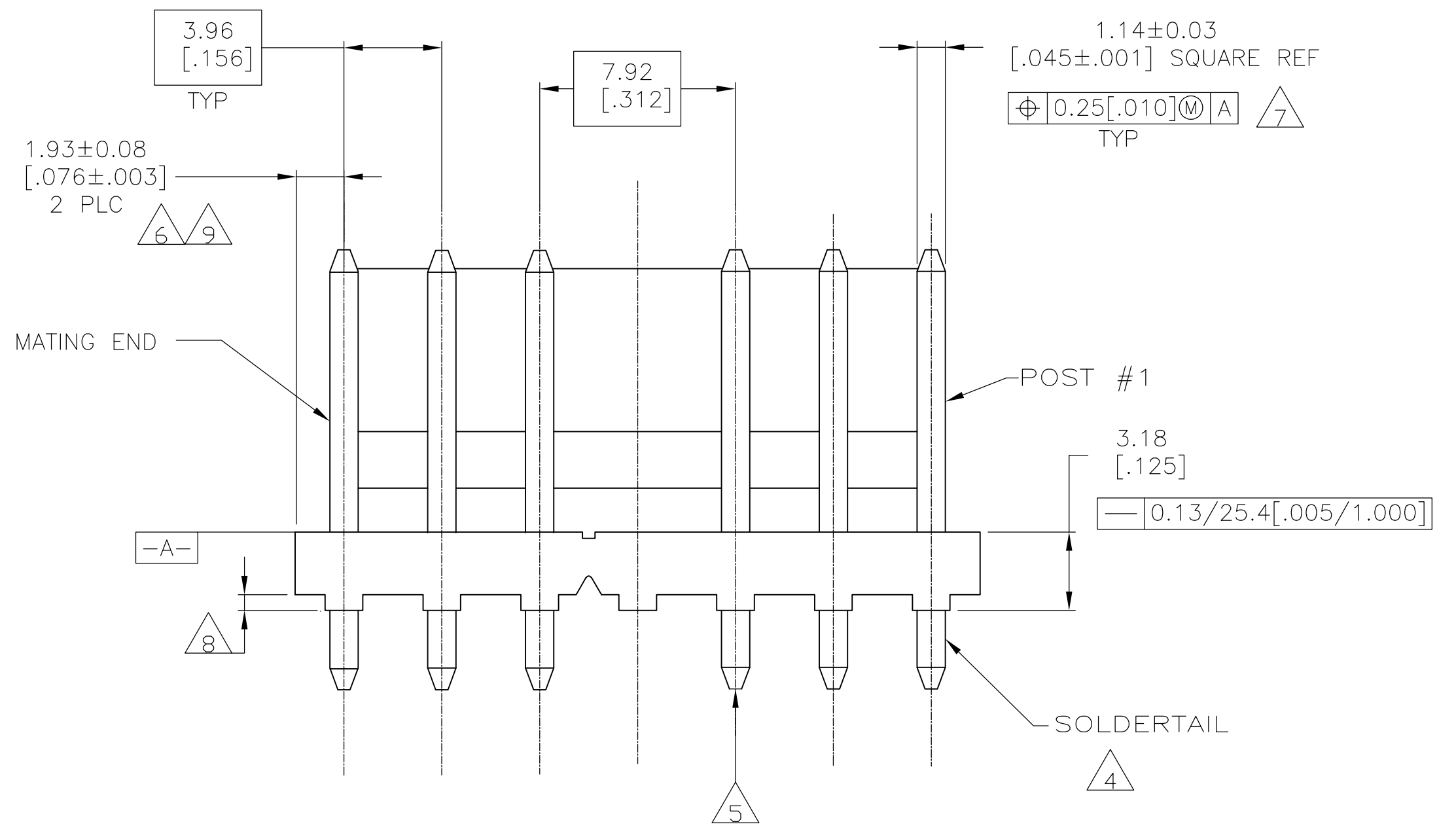

RECOMMENDED MOUNTING HOLE PATTERN FOR 1.57 [.062] THICK P.C. BOARD

- 1 MATERIAL
HOUSING: THERMOPLASTIC POLYESTER, GLASS FILLED, DR-48. UL94V-0.
POST: COPPER ALLOY
- 2 FINISH
HOUSING: BLACK
POST: BRIGHT TIN-LEAD (93/7) PLATE, 0.00380-0.00880 [.000150-.000350] THK OVER NICKLE UNDERPLATE, 0.00130 [.000050] MIN THK.
OR MATTE TIN PLATE 0.00380(.000150)-.00880(.000350) OVER NICKLE UNDERPLATE 0.00130 (.000050) MIN THICK IF LEAD FREE.
- 3 UL MARKING MAY NOT APPEAR ON THE 3 POSITION SIZE.
- 4 POST SOLDERTAILS COMPLY WITH AMP SOLDERABILITY SPEC 109-11-2.
- 5 POST WITHSTANDS 13.34N [3 LB] MIN AXIAL FORCE IN EITHER DIRECTION WITHOUT DISLODGING.
- 6 APPLIES AT -A-
- 7 APPLIES WHEN THE HEADER IS STRAIGHT.
- 8 PLASTIC PROJECTIONS PERMITTED IN THIS ZONE.
- 9 COORDINATE DIMENSIONS APPLIES FROM THE CENTER OF THE ACTUAL FEATURE.
- 10 SOLDER SIDE OF BOARD IS SHOWN.
- 11. DIMENSIONS IN BRACKETS ARE IN INCHES.
- 12 ALL POSITION SIZES HAVE THE BACKWALL NOTCHED ON BOTH ENDS AS SHOWN. THE 2 THRU 5 POSITION SIZES HAVE SOLID BACKWALLS. POSITION SIZES 6 AND ABOVE HAVE AN INTERRUPTED BACKWALL AT VARIOUS LOCATIONS (SEE TABLE FOR INTERRUPTION(S) LOCATIONS).
- 13 EDGE OF POLARIZING LOCK WALL TO BE IN LINE WITH CENTERLINE OF ADJACENT POST WITHIN ± 0.13 [.005].
- 14 NOTCH SHOWN MAY OR MAY NOT APPEAR.
- 15 OBSOLETE PART NUMBER

FINISH	BACK WALL INTERRUPTION(S) BETWEEN POST	L	NO OF POSITIONS	PART NO
TIN	4 & 5	27.61 [1.087]	7	3-647183-7
TIN-LEAD	4 & 5	27.61 [1.087]	7	647183-7

THIS DRAWING IS A CONTROLLED DOCUMENT.

DIMENSIONS: mm [INCHES]	TOLERANCES UNLESS OTHERWISE SPECIFIED:	DRAWN: R. LEWIS 21APR98	CHK: R. SWING 21APR98	APPROVED: C. JONES 21APR98	NAME: MTA-156 HEADER ASSEMBLY, POLARIZED LOCK, STRAIGHT, .045 SQUARE POST TIN OR TIN-LEAD PLATED WITHOUT RETENTION PEGS, NO 4 POST OMITTED, SPECIAL
0 PLC ± -	1 PLC ± -	2 PLC ± 0.15 [0.005]	3 PLC ± -	4 PLC ± -	ANGLES ± 1'
MATERIAL: 1	FINISH: 2	WEIGHT: -	SIZE: A1	CAGE CODE: 00779	DRAWING NO: 647183
CUSTOMER DRAWING		SCALE: 5:1	SHEET: 1 OF 1	REV: E2	

