

MATERIALS & SPECIFICATIONS

PART NO.	A 79021-001	REV	ECO	DATE	APP
		C	99101	12-06-12	TLM

INSULATOR:

THERMOPLASTIC PER MIL-M-24519, TYPE GLCP-30F OR GST-40F NATURAL

CONTACT:

COPPER ALLOY PER MIL-DTL-32139. GOLD PLATED PER ASTM B488, (HARD GOLD) TYPE II CODE C CLASS 1.27

TERMINATION:

34 AWG (7-42) PTFE, COLOR CODED PER TABLE

GUIDE POST:

BERYLLIUM COPPER ALLOY PER ASTM B196. ELECTROLESS NICKEL PER SAE-AMS-2404

CURRENT CAPACITY:

1 AMP MAX PER MIL-DTL-32139

CONTACT RESISTANCE:

71 MILLIOHMS (71mV) MAX @ 1.0 AMPS PER MIL-DTL-32139

SOCKET #	COLOR
1, 11	BLACK
2, 12	BROWN
3, 13	RED
4, 14	ORANGE
5, 15	YELLOW
6, 16	GREEN
7, 17	BLUE
8, 18	VIOLET
9	GRAY
10	WHITE

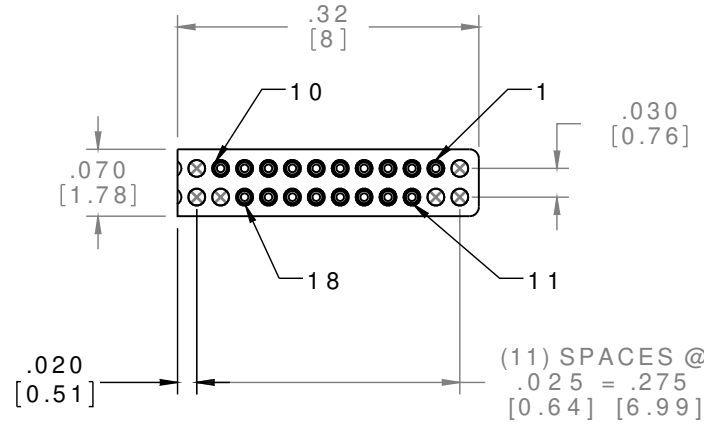

ACTUAL SIZE EXCLUDING WIRE LENGTH

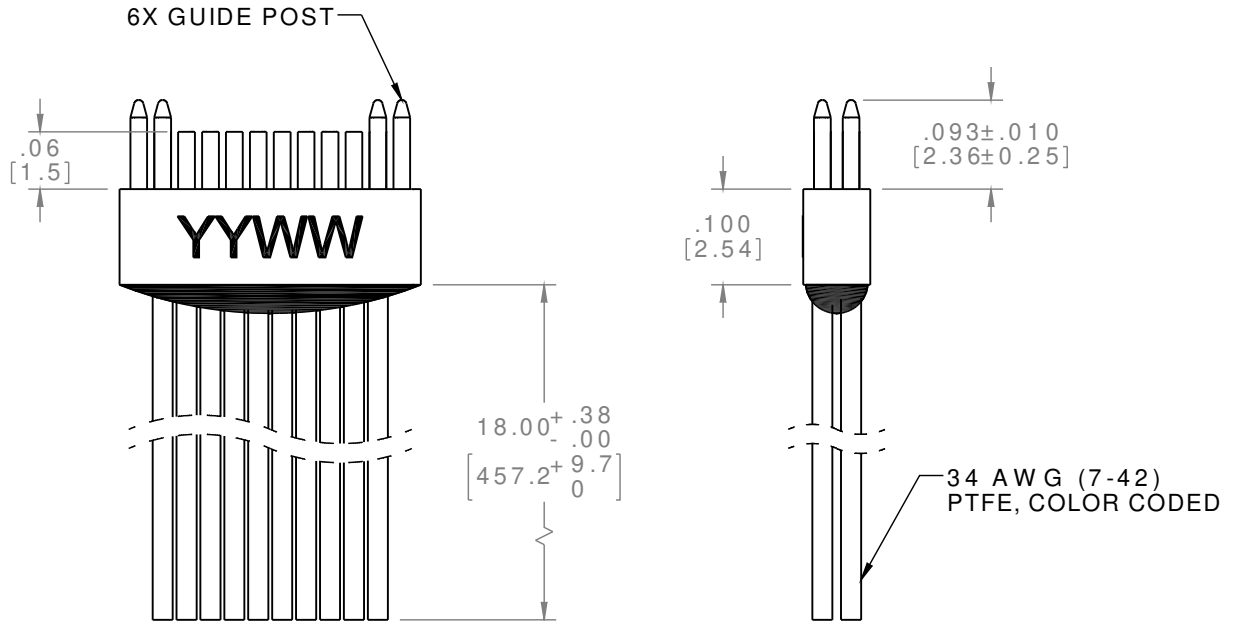

RoHS

NOTE:

DIMENSIONS IN [] ARE IN MILLIMETERS UNLESS OTHERWISE NOTED AND ARE FOR REFERENCE ONLY

NSD S/D M/D	THIRD ANGLE
	-TOLERANCES-
	UNLESS OTHERWISE NOTED
	DIMENSIONS IN INCHES
2	PL DEC ± .01
3	PL DEC ± .005
4	PL DEC ± .0005
	ANGLES ± 1°

THIS DRAWING CONTAINS CONFIDENTIAL AND PROPRIETARY INFORMATION WHICH IS THE PROPERTY OF OMNETICS CONNECTOR CORP. THIS DOCUMENT MAY NOT, IN WHOLE OR IN PART, BE DUPLICATED, OR DISCLOSED FOR ANY PURPOSE, WITHOUT WRITTEN PERMISSION FROM OMNETICS CONNECTOR CORP.	
DFTM. TLM	DATE 01-20-11
CHK'D.	DATE
APP'D.	DATE
TITLE: (18) SOCKET FEMALE DUAL DUAL ROW CONNECTOR W/GUIDE POSTS	

OMNETICS
CONNECTOR CORPORATION
7260 COMMERCE CIRCLE EAST
MINNEAPOLIS, MN 55432
WWW.OMNETICS.COM

CAGE CODE 61873
DWG NO. A79021-001
SHEET 1 OF 2
SCALE: 5:1
REV C