

DIY LiPo Supercharger Kit

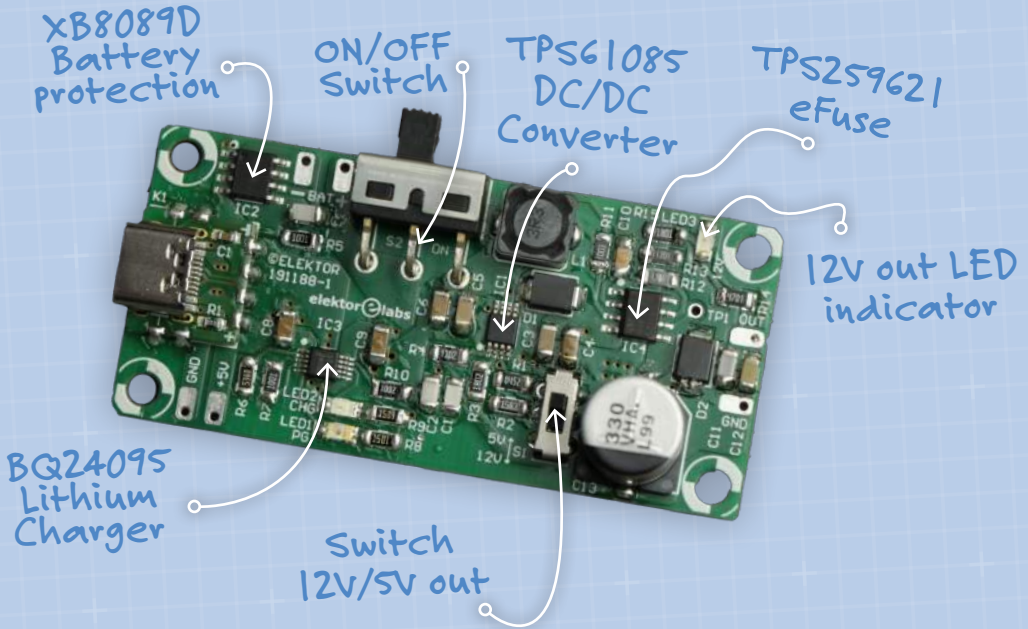

←
a bit of a
byte inside



SKU 19525

GreatScott! DIY LiPo Supercharger Kit

This DIY LiPo Supercharger developed by GreatScott! and produced by Elektor can charge a single-cell LiPo battery and protect it against the effects of overvoltage, overload, and short-circuits. Additionally, it can boost the battery voltage to 5 V or 12 V. The boosted output voltage is protected by an 'eFuse' IC outputting 1.52 A at 5 V or 0.76 A at 12 V maximum. The charger part of the circuit needs a +5 V power supply which can be connected through USB-C, or simply two wires soldered to pads on the PCB. In addition, other connections can be soldered to pads on the PCB or by using single pinheaders.

Specifications

Input Voltage	+5 V / 2 A max.
LiPo Protection (XB8089D)	
Overcharge Detection	4.250 V
Overcharge Release	4.10 V
Overdischarge Detection	2.50 V
Overdischarge Release	3 V
Overcurrent Detection	10.0 A
Output Voltage	5 V / 1.52 A 12 V / 0.76 A
Thermal Shutdown	Auto-retry
Enable/Undervoltage Lockout	Rising: 1.2 V (typ.) Falling: 1.1 V (typ.)

How it works

By looking at the [circuit diagram](#) of the LiPo Battery Charger you should be able to discern three blocks:

1. protection (IC2, an XB8089D);
2. charger (IC3, a BQ24092DGQR);
3. the power supply part (2 ICs; separate protection) which can be set two output voltages, 5 V or 12 V, by operating slide switch S1A-B – the relevant current limit is set either by R12 or R12||R13 connected in circuit by S1B.

The **XB8089D** IC is described as a *high integration solution for lithium-ion/polymer battery protection*. This IC contains advanced power MOSFET, high-accuracy voltage detection circuits and delay circuits. It also protects against reverse connection of the battery cell and a lot more. For more information, please look at the datasheet.

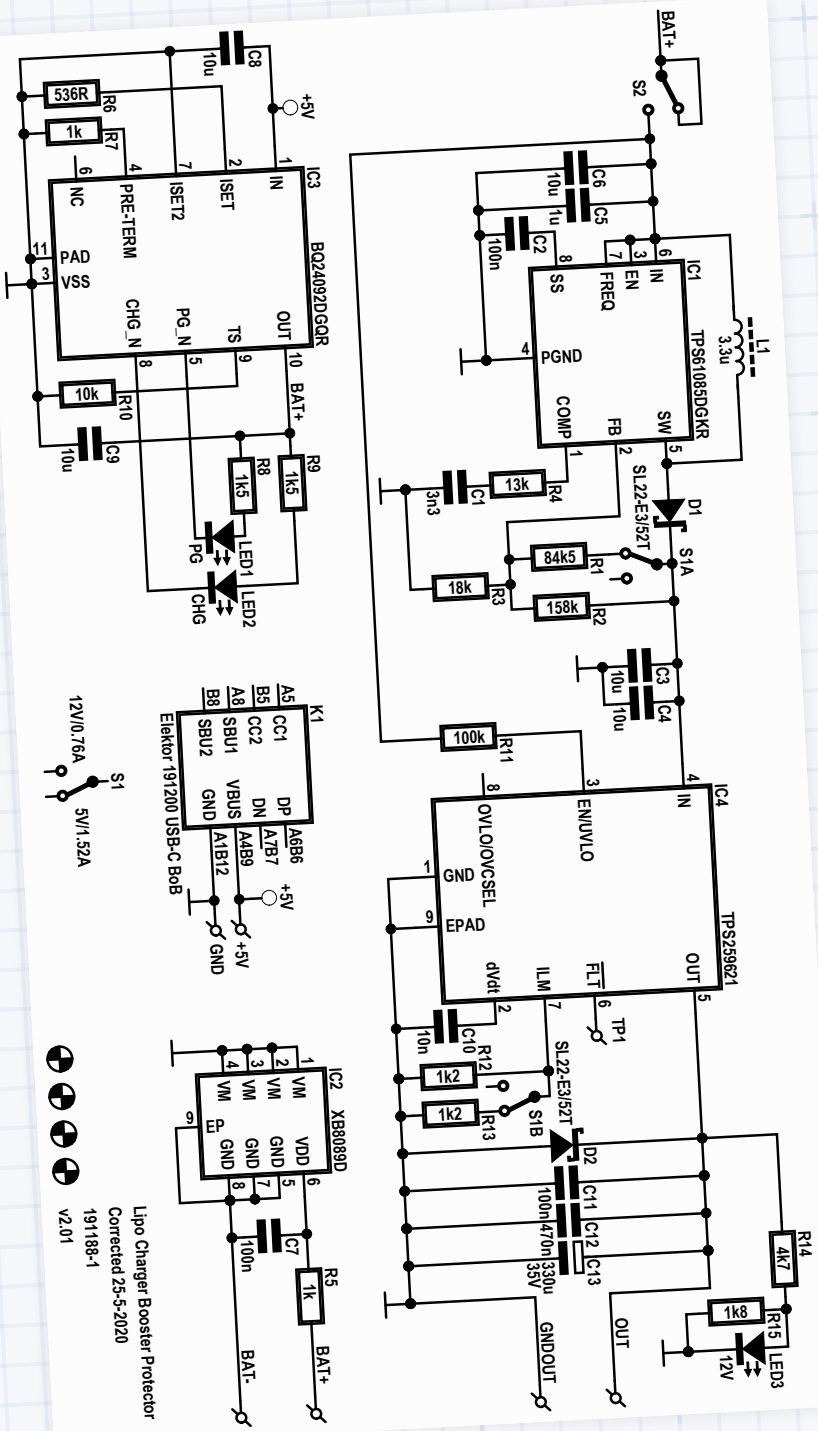

Lipo Charger Booster Protector
 Corrected 25-5-2020
 191188-1
 v2.01

The **BQ24092DGQR** is described as a 1A, *Single-Input, Single Cell Li-Ion and Li-Pol Battery Charger*. The charger also comes with a full set of safety features: JEITA Temperature Standard, Over-Voltage Protection, Input Voltage Dynamic Power Management, Safety Timers, OUT Short-Circuit Protection, and ISET Short Detection. The temperature sense pin TS is not used here, and a regular 10 kΩ resistor (R10) is connected instead of a NTC thermistor. The IC pin named ISET programs the fast-charge current setting. Here, it's resistor R6 setting about 1 A of fast-charge current. R7 programs the Current Termination Threshold and Sets the Pre- Charge Current to twice the Termination Current Level. LED1 indicates the input voltage of the IC is above UVLO and the OUT (battery) voltage. LED2 indicates charging (ON) or no charging or charge complete (OFF). For more information go have a look at the datasheet and concentrate on the different types in the BQ2409x family!

The power supply part consists of Step-Up DC-DC Converter type TPS61085DGKR (IC1) and 'eFuse' TPS259621 (IC4). The output voltage of the step-up converter is set to either 5 V or 12 V by S1A changing the voltage divider R1||R2, R3 for the feedback of the output voltage. For 5 V out, R1||R2 and R3 are in action, for 12 V, R2 and R3. To protect the LiPo battery from a short circuit or overload an eFuse is added but also protects against undervoltage, pin 3 is connected to the battery (R11) after the circuit is turned

on by S2. The output current limit is set to one of two values by R12 and R13 on S1B: 1.52 A for 5 V (R12||R13) and 0.76 A for 12 V (R12 only).

The +5 V input voltage can be a USB-C power adapter by way of a break-out-board (Elektor Store no. 191200) or connected by wires to the +5 V and GND solder pads next to it. The battery must be connected to solder pads BAT+ and BAT-. The output voltage can be taken from the pads labelled OUT and GND.

Construction

Build the GreatScott! LiPo Charger Kit using the photo story and step by step instructions in the Assembly Manual further on in this document. Also refer to the Bill of Materials and the PCB overlays for selection and positioning of the parts on the board.

Tips & Tricks on SMD

SMD resistors

On most SMD resistors the value is mentioned with the aid of 3 or 4 digits, depending on tolerance, much like the colour bands used on through-hole resistors. With 3 digits printed: the first two are the value, and the third digit is the multiplier. With 4 digits printed: 3 digits are the numerical value, and the fourth digit is the multiplier.

Example 1: 3-digit code '103' means $10 \times 10^3 = 10,000 \Omega = 10 \text{ k}\Omega$.

Example 2: 4-digit code '8452' means $845 \times 10^2 = 84,500 \Omega = 84.5 \text{ k}\Omega$.

SMD capacitors

Ceramic capacitors have no part value code printed on them. To find out the value of a particular capacitor you'll need a capacitance meter. There are special tweezer-like versions for SMD components that can measure capacitance, resistance, and more. In many cases, even cheap multimeters also have a capacitance (C) range. The only distinction that can be made is the dielectric material. NP0/C0G (typ. 1 pF to 1 nF) is often white/light grey, X7R (1 nF to 1 μ F) is light brown, and X5R, dark brown (>1 μ F). But the values can overlap depending on maximum voltage while the colour can depend on manufacturer, and the specific composition of the dielectric. Electrolytic capacitors in SMD guises are often chip-type versions, with a square black plastic bottom and two chamfered corners at the positive connection, like C13. The code for the

value is like that on ordinary through-hole versions. The three digits are the value in microfarads (μ F), so '330' indicates 330 μ F.

The capacitance ranges mentioned here are typical for 50-V rated capacitors and are subject to considerable overlap in practice.

SMD LEDs

The cathode of an LED is often indicated by a very small dot on the top side that's sometimes difficult to see. Usually a marking is also found on the bottom, like a triangle-like diode symbol, and that may be easier to recognize.

SMD ICs

SOIC (having pins in 1.27-mm grid) and TSSOP (having pins on a 0.65 mm grid) packages have a small round indentation on top, or a notch on a side marking the position of pin 1. Most manufacturers create a small chamfer on the side of the package at the row of pins where pin 1 is located.

Soldering SMD parts

Soldering 1206-style resistors and capacitors shouldn't be a problem. Solder one side while holding the component with a tweezer or similar without moving it, then solder the other side. Moving a component while the solder joint cools down gives a poor connection, electrically and mechanically. A soldering iron with a

fine tip is advisable. Use thin solder, 0.5 mm or 0.35 mm diameter. The use of 0.8 mm or larger diameter solder will result in solder joints with too much

solder and may cause short-circuits. Always check the PCB thoroughly while soldering and afterwards as well.

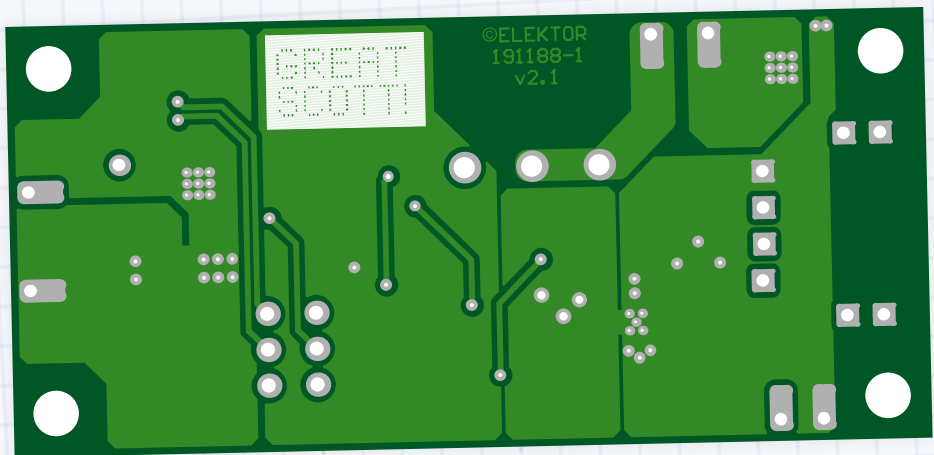
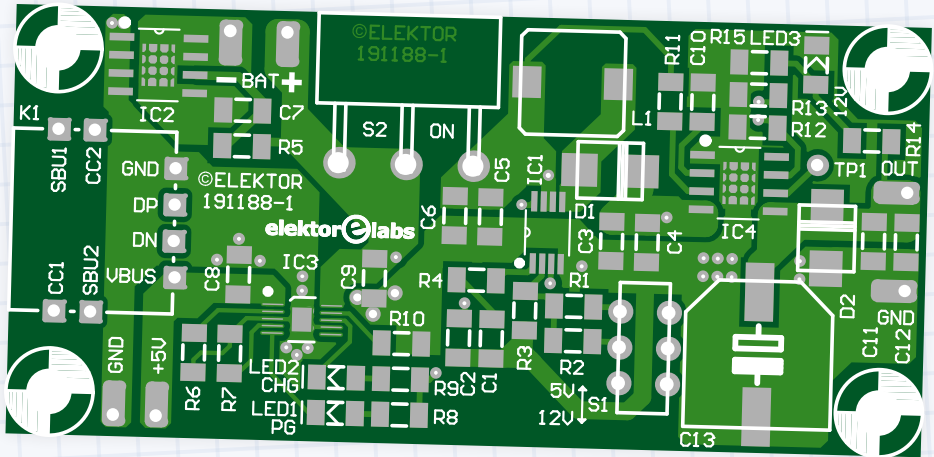

Bill of Materials

Resistors

- ▶ R1 = 84.5 k Ω , 1 %, 0.25 W, SMD 1206
- ▶ R2 = 158k Ω , 1 %, 0.25 W, SMD 1206
- ▶ R3 = 18 k Ω , 1 %, 0.25 W, SMD 1206
- ▶ R4 = 13 k Ω , 1 %, 0.25 W, SMD 1206
- ▶ R5,R7 = 1 k Ω , 1 %, 0.25 W, SMD 1206
- ▶ R6 = 536 Ω , 1 %, 0.25 W, SMD 1206
- ▶ R8,R9 = 1.5 k Ω , 1 %, 0.25 W, SMD 1206
- ▶ R10 = 10 k Ω , 1 %, 0.25 W, SMD 1206
- ▶ R11 = 100 k Ω , 1 %, 0.25 W, SMD 1206
- ▶ R12,R13 = 1.2 k Ω , 1 %, 0.25 W, SMD 1206
- ▶ R14 = 4.7 k Ω , 1 %, 0.25 W, SMD 1206
- ▶ R15 = 1.8 k Ω , 1 %, 0.25 W, SMD 1206

Capacitors

- ▶ C1 = 3.3 nF, 5 %, 50 V, NP0, SMD 1206
- ▶ C2,C7,C11 = 100 nF, 5 %, 50 V, C0G, SMD 1206
- ▶ C3,C4,C6,C8,C9 = 10 μ F, 10 %, 25 V, X7R, SMD 1206
- ▶ C5 = 1 μ F, 10 %, 50 V, X7R, SMD 1206
- ▶ C10 = 10 nF, 5 %, 50 V, X7R, SMD 1206
- ▶ C12 = 470 nF, 10 %, 50 V, X7R, SMD 1206
- ▶ C13 = 330 μ F, 20 %, 35 V, SMD 10.3x10.3

Inductors

- ▶ L1 = SCDS74T = 3.3 μ H, 20 %, 3.5 A, 35 m Ω , SMD size 7.3x7.3x4.5mm

Semiconductors

- ▶ D1,D2 = SL22-E3/52T, SMD SMB
- ▶ LED1 = 11-21/GPC-AM2P1/2T, LED, green, SMD 1206
- ▶ LED2,LED3 = 15-21SDRC/S530-A2/TR8, LED, red, SMD 1206
- ▶ IC1 = TPS61085DGKR, SMD VSSOP-8
- ▶ IC2 = XB8089D, SMD SOIC-8-EP
- ▶ IC3 = BQ24092DGQR, SMD MSOP-10-EP
- ▶ IC4 = TPS259621DDAR, SMD SO-PowerPad-8

Miscellaneous

- ▶ S1 = switch, DPDT, THT, 9.1x3.5 mm (K2-2235D-F1)
- ▶ S2 = switch, SPDT, 250 VAC, 3 A (XKB, SS-12D06L5)
- ▶ K1 = USB-C BoB, Elektor Store no. 191200

Optional

- ▶ PC1-PC6 = pinheader pin, 1x1 (BAT+/BAT-; +5V/GND; OUT/GND)
- ▶ PCB 191188-1 v2.1

Assembly Manual

for The GreatScott! DIY LiPo Supercharger Kit

Tools and materials required:

- ▶ Solder iron. Make sure to have a solder iron (or even better, a solder station) within easy reach. You can use any solder tip you are comfortable with, but having a fine-shaped tip really facilitates work with the small SMD components. Still, a larger tip is recommended for some components since the GND layer of the PCB absorbs appreciable heat at some points.
- ▶ Tweezers. You will need a pair of tweezers to properly position the SMD components and secure them in place while soldering. Alternatively, use a magnifying glass or a microscope to identify the SMD components.

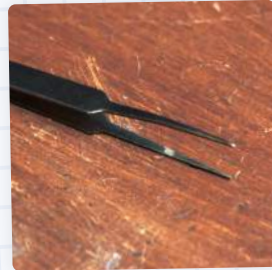

- ▶ 0.8-mm diameter solder. Feel free to use the type of solder wire you are comfortable to work with, but the 0.8mm diameter type is recommended because it is more convenient to use with small SMD components.



- ▶ Electrical tape. Not mandatory but really useful to hold the PCB in place while soldering.

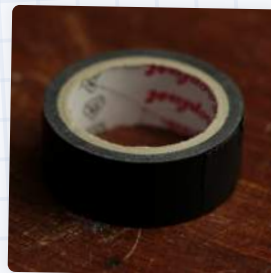

Steps:



1

Heat up your soldering iron. Use a temperature of around 360 degrees Celsius for most of the SMD solder connections. You will notice though that some solder joints will be harder to create due to the heat absorption by the copper mass that forms the GND layer. There you can use 400 degrees Celsius.

2

Secure your PCB in place with pieces of electrical tape and start soldering the SMD resistors in place. Make sure to follow the labelling of the resistors to ensure they are soldered in the correct PCB locations. Make sure to watch the GreatScott! video about this circuit to see how I solder such components.



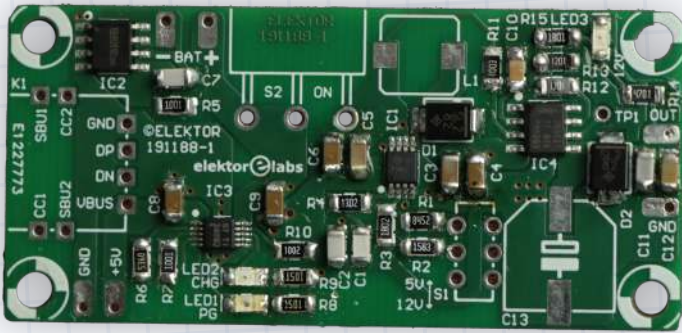

3

Now solder the capacitors, LEDs and diodes in place just like you did it with the resistors.

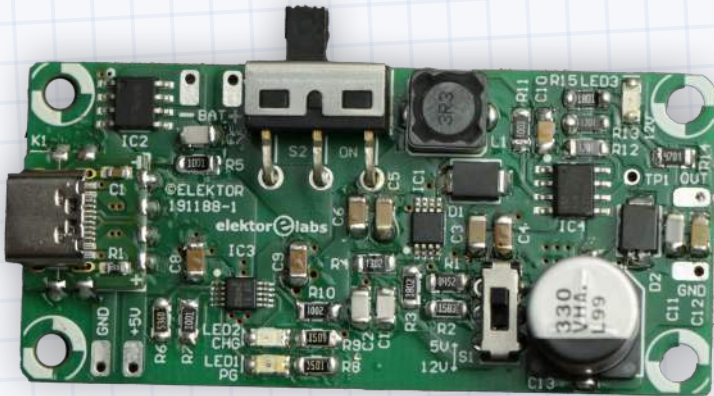

4

After adding the remaining components (USB Type C port, large capacitor and inductor, two switches) you are basically done with the PCB.

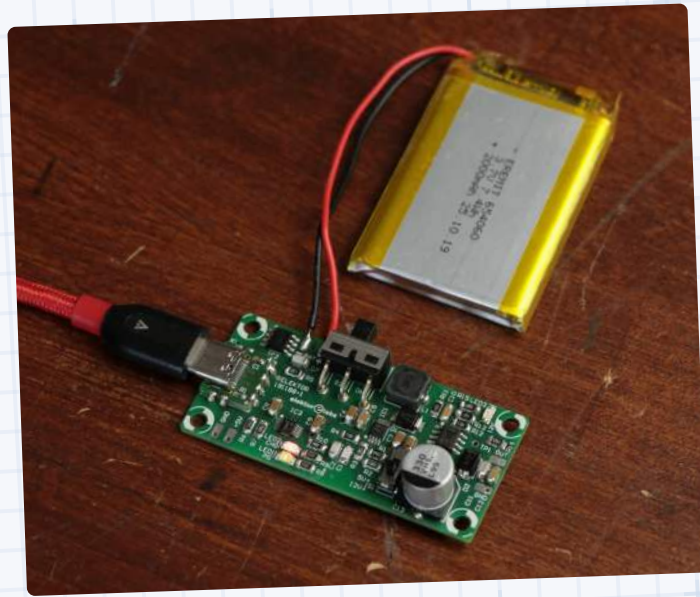

5

Hook up your LiPo battery to the BAT+ and BAT- pins and charge the battery.

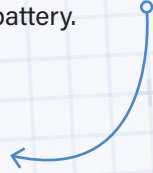

6

Turn on the output of the Boost Converter and check for the presence of 5 V and 12 V on the output terminals

