

STRAIGHT PLUG FULL CRIMP TYPE

R110.083.120

CABLE 2.6/50 S

Series : MMCX

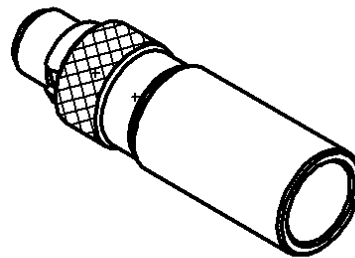
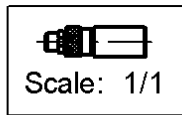
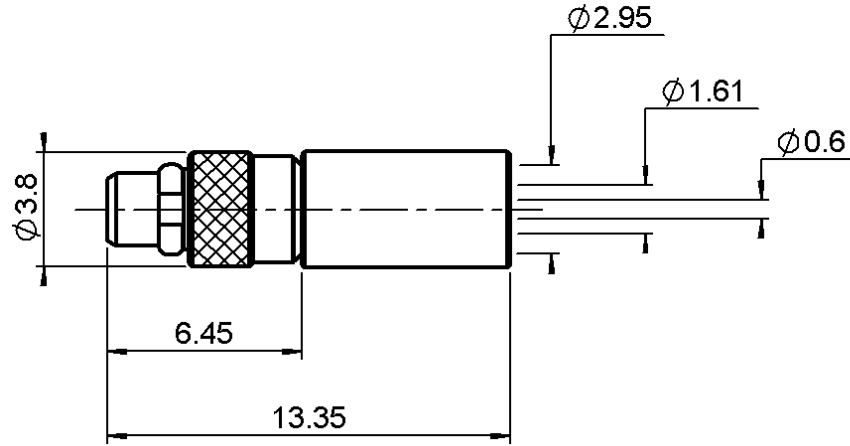

All dimensions are in mm.



COMPONENTS	MATERIALS	PLATING (µm)
BODY	BRASS	.GOLD 0.2 OVER NICKEL 2
CENTER CONTACT	BRASS	.GOLD 1.3 OVER NICKEL 2
OUTER CONTACT	-	-
INSULATOR	PTFE	-
GASKET	-	-
OTHERS PARTS	-	-
-	-	-
-	-	-

Issue : 0741 A

In the effort to improve our products, we reserve the right to make changes judged to be necessary.



STRAIGHT PLUG FULL CRIMP TYPE

R110.083.120

CABLE 2.6/50 S

Series : MMCX

PACKAGING

Standard	Unit	Other
100	'W' option	Contact us

SPECIFICATION

ELECTRICAL CHARACTERISTICS

Impedance	50	Ω
Frequency	0-6	GHz
VSWR	1.22 + 0,0000	x F(GHz) Maxi
Insertion loss	TBD	\sqrt{F} (GHz) dB Maxi
RF leakage	- (- F(GHz)) dB Maxi
Voltage rating	335	Veff Maxi
Dielectric withstanding voltage	750	Veff mini
Insulation resistance	1000	M Ω mini

CABLE ASSEMBLY

Stripping	a	b	c	d	e	f
mm	1,60	5,30	8,80	0,00	7,20	0,00

Assembly instruction : **Crimp 02**

Recommended cable(s)

KX 22A

RG 188

RG 316

Characteristics indicated on this data sheet are those that can be achieved with the highest performance cable. Intrinsic limitations of the cable may diminish the performance of the assembly

Cable retention

- pull off **53** N mini
- torque **NA** N.cm

MECHANICAL CHARACTERISTICS

Center contact retention		
Axial force – Mating end	NA	N mini
Axial force – Opposite end	NA	N mini
Torque	NA	N.cm mini

TOOLING

Part Number	Description	Hexagon
.	.	.
R282.271.000	CRIMPING TOOL	3.25
R282.281.000	CRIMPING TOOL	2x4 (pos. 3)
R282.293.000	CRIMPING TOOL M22520/5-01	-
R282.235.003	CRIMPING DIES	3.25
R282.967.070	POSITIONER FOR CRIMPING TOOL R282281	

Recommended torque		
Mating	NA	N.cm
Panel nut	NA	N.cm
Clamp nut	NA	N.cm
A/F clamp nut	0,0000	mm

Mating life	500	Cycles mini
Weight	0,6980	g

ENVIRONMENTAL

Operating temperature	-55/+155	$^{\circ}$ C
Hermetic seal	NA	Atm.cm3/s
Panel leakage	NA	

OTHER CHARACTERISTICS

Issue : 0741 A

In the effort to improve our products, we reserve the right to make changes judged to be necessary.

