

Absolute maximum ratings

($T_a=25^\circ\text{C}$)

Symbol	Ratings		Unit
	NPN	PNP	
V_{CBO}	60	-60	V
V_{CEO}	60	-60	V
V_{EBO}	6	-6	V
I_C	4	-4	A
I_B	0.5	-0.5	A
P_T	5 ($T_a=25^\circ\text{C}$)		W
	25 ($T_c=25^\circ\text{C}$)		
V_{ISO}	1000 (Between fin and lead pin, AC)		V_{rms}
T_j	150		$^\circ\text{C}$
T_{stg}	-40 to +150		$^\circ\text{C}$
θ_{j-c}	5		$^\circ\text{C/W}$

Equivalent circuit diagram

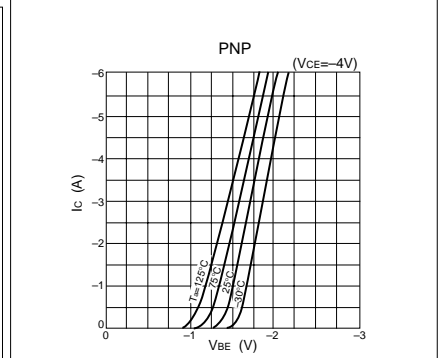
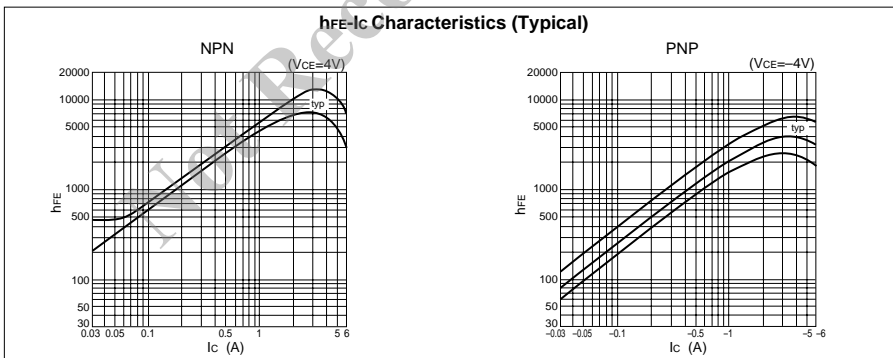
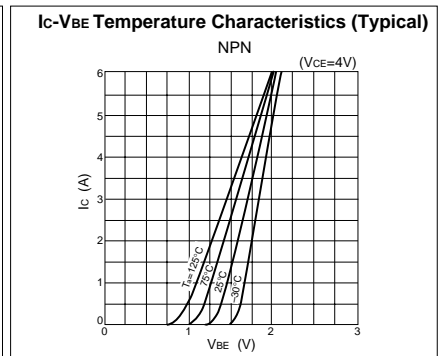
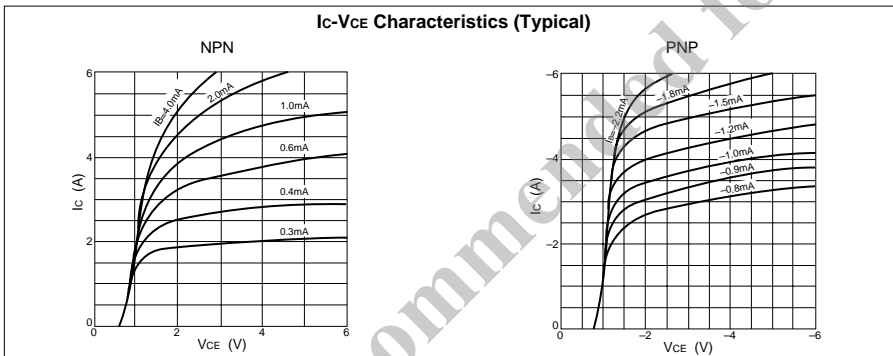
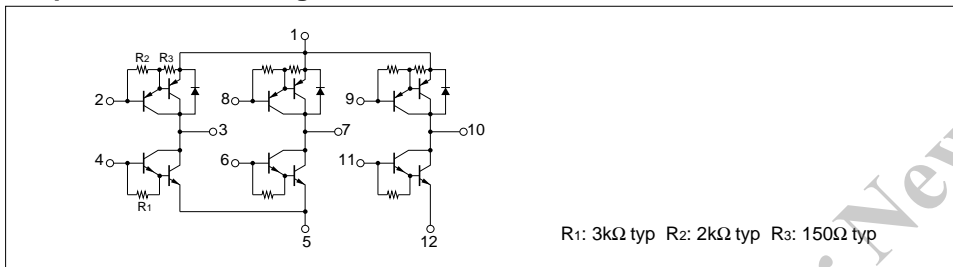

Electrical characteristics

($T_a=25^\circ\text{C}$)

Symbol	NPN					PNP				
	Specification			Unit	Conditions	Specification			Unit	Conditions
	min	typ	max			min	typ	max		
I_{CBO}			10	μA	$V_{CB}=60\text{V}$			-10	μA	$V_{CB}=-60\text{V}$
I_{EBO}			10	μA	$V_{EB}=6\text{V}$			-10	mA	$V_{EB}=-6\text{V}$
V_{CEO}	60			V	$I_C=10\text{mA}$	-60			V	$I_C=-10\text{mA}$
hFE	2000				$V_{CE}=4\text{V}, I_C=3\text{A}$	2000				$V_{CE}=-4\text{V}, I_C=-3\text{A}$
$V_{CE}(\text{sat})$			1.5	V	$I_C=3\text{A}, I_B=6\text{mA}$			-1.5	V	$I_C=-3\text{A}, I_B=-6\text{mA}$

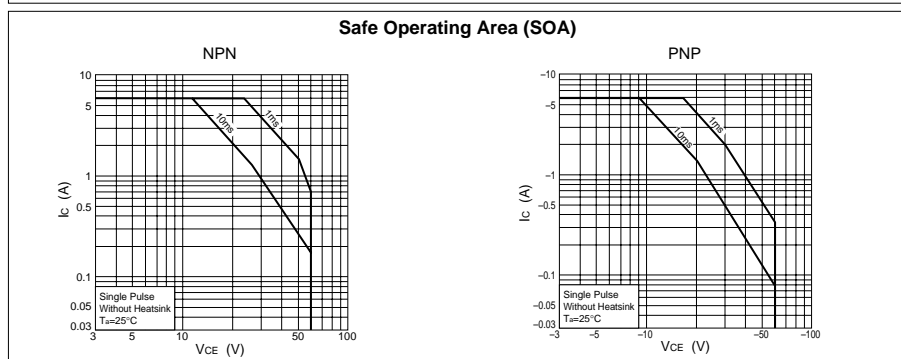
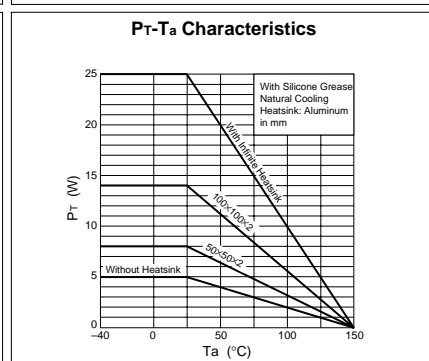
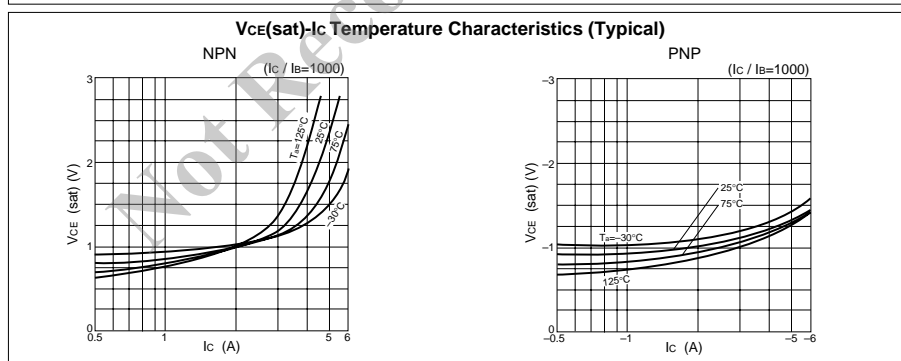
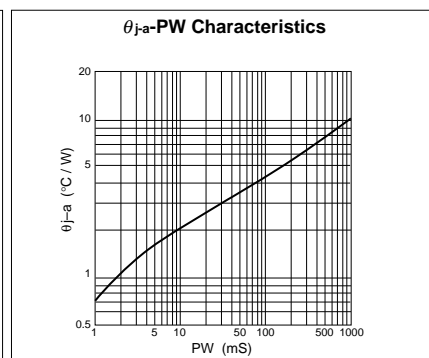
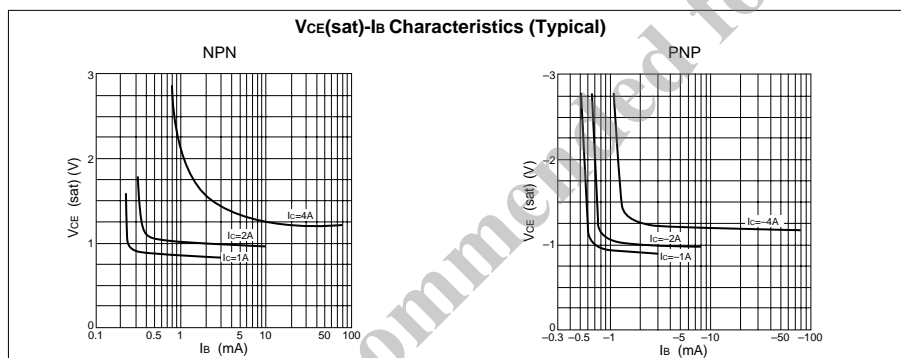

• SIP 8 (STA8Pin)

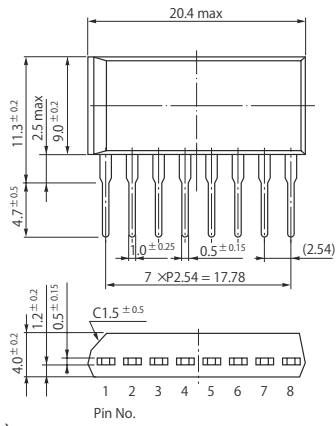

• SIP 10 (STA10Pin)

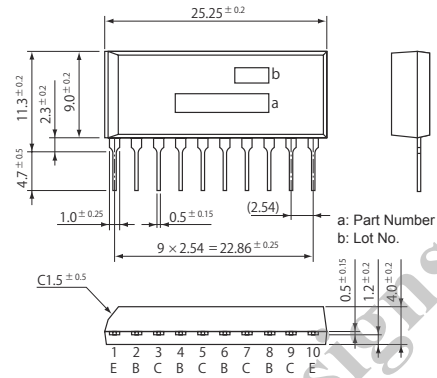

• SIP 12 (SMA12Pin)

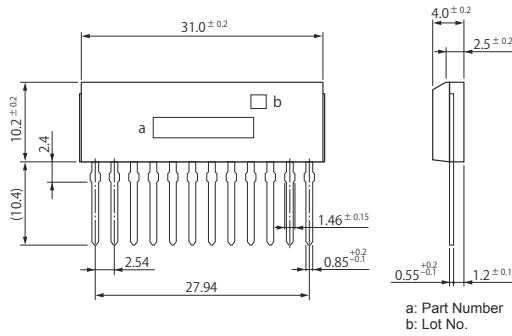

• SIP 15 (SMA15Pin)

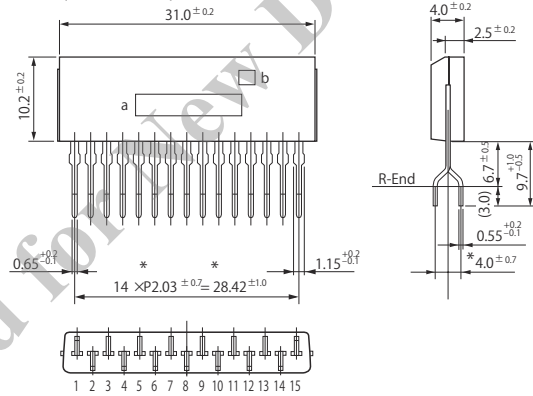

• SIP 12 with Fin (SLA12Pin)

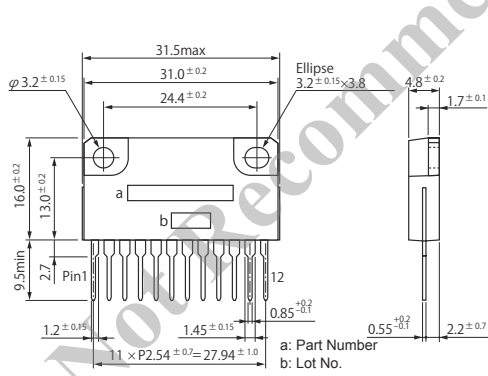

• SIP 15 with Fin (SLA15Pin)

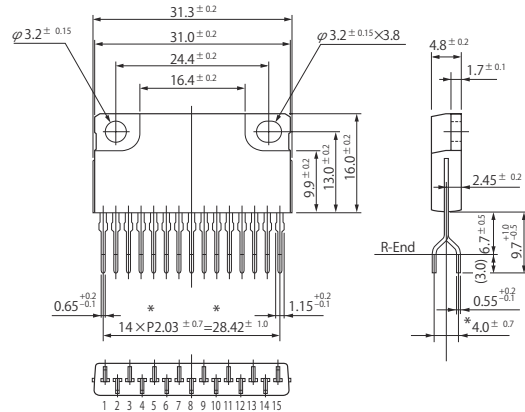

• SIP 21 with Fin (SLA21Pin)

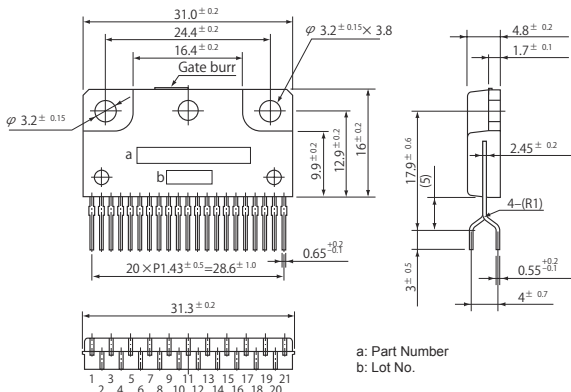

(Unit:mm)