

A.3: Validé

SIDE VIEW FOR EACH VERSION

UTGX6JC-----PSCR

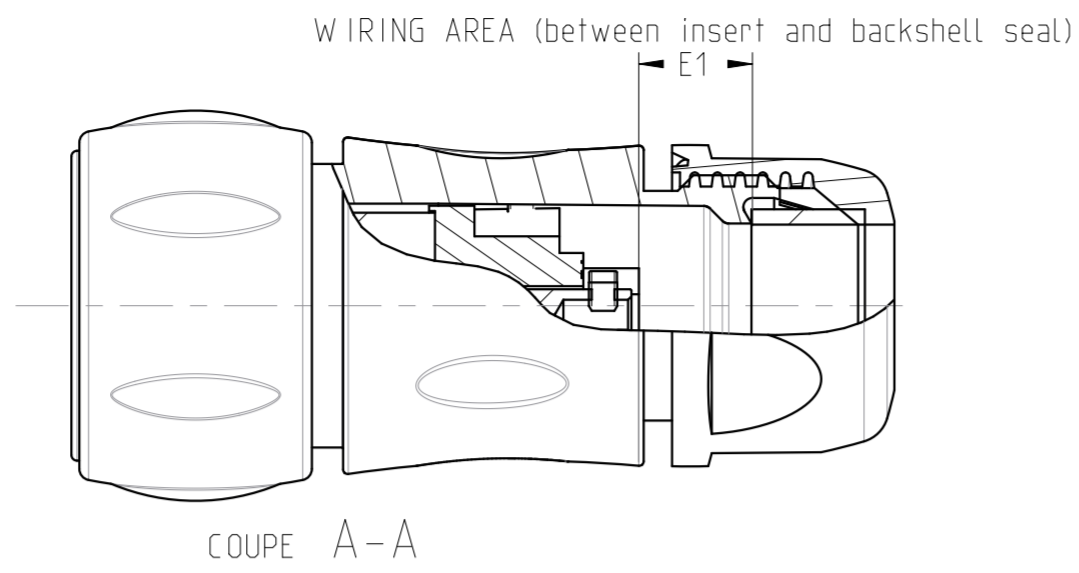

UTGX6JC-----SSCR

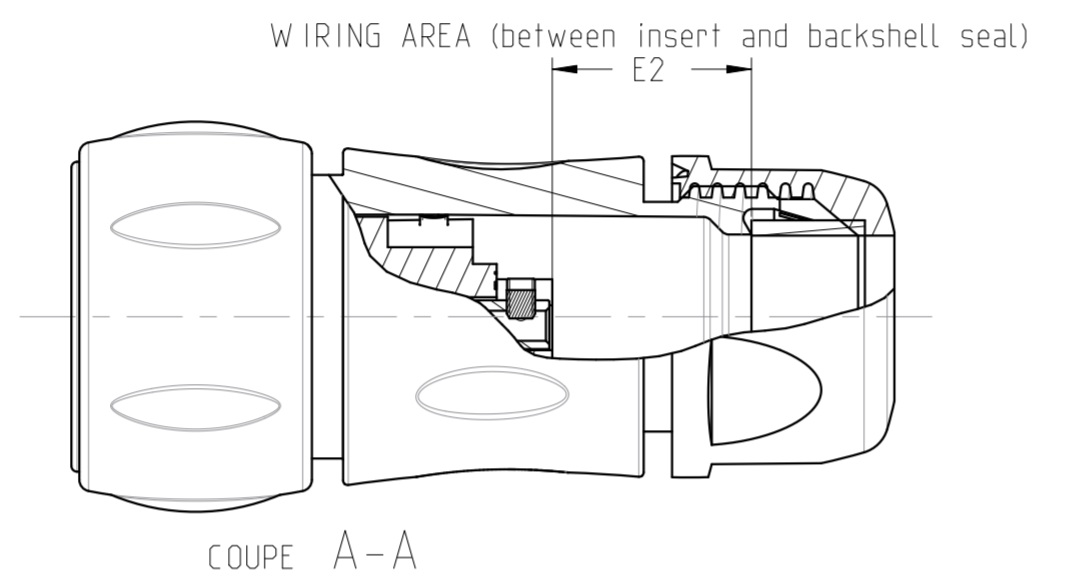

MATERIAL :

- SHELL : PA UL94 V0, UL746C F1 Black color
- COUPLING RING: PA + Nickel plated brass
- BACKSHELLS : PA UL94 V0 F1 Black color
- BACKSHELL Seal : CR
- INSERT : PA UL94 V0, UL746C F1
- O'RING : NITRIL
- MATING SEAL : SILICON
- CONTACT SPRING: copper alloy
- CONTACT BODY : brass, gold and nickel plated
- SCREW : stainless steel

PERFORMANCE CHARACTERISTICS

Operating temperature: -40°C up to 105°C  
 Insulation resistance: 5000 MΩmin  
 Corrosion salt spray: 500 hours  
 Durability: 500 matings and unmatings

Sealing conditions: SEE TABLE

NOTA:

- 1- Contact to be ordered separately for version UTGX0----- : refer to corresponding catalogue.
- 2- Insert arrangement refer to:  
 C008-UTS1-A(female insulator)  
 C007-UTS1-A (male insulator)
- 3- This part shall be used at the place of the standard seal to accomodate with different cable Ø
- 4- Plug, backshell and the reducing seal are delivered as a kit. The backshell already includes the standard seal.

SEALING CONDITIONS

Sealing in MATED conditions with COUNTERPART:  
 -IP68 1 bar during 1 week: immersion under 10 m of water. (IEC 60529)  
 -IP69K : exposure to high pressure water of cleaning equipment (DIN 40050)

COMMON QUOTES FOR ALL VERSION

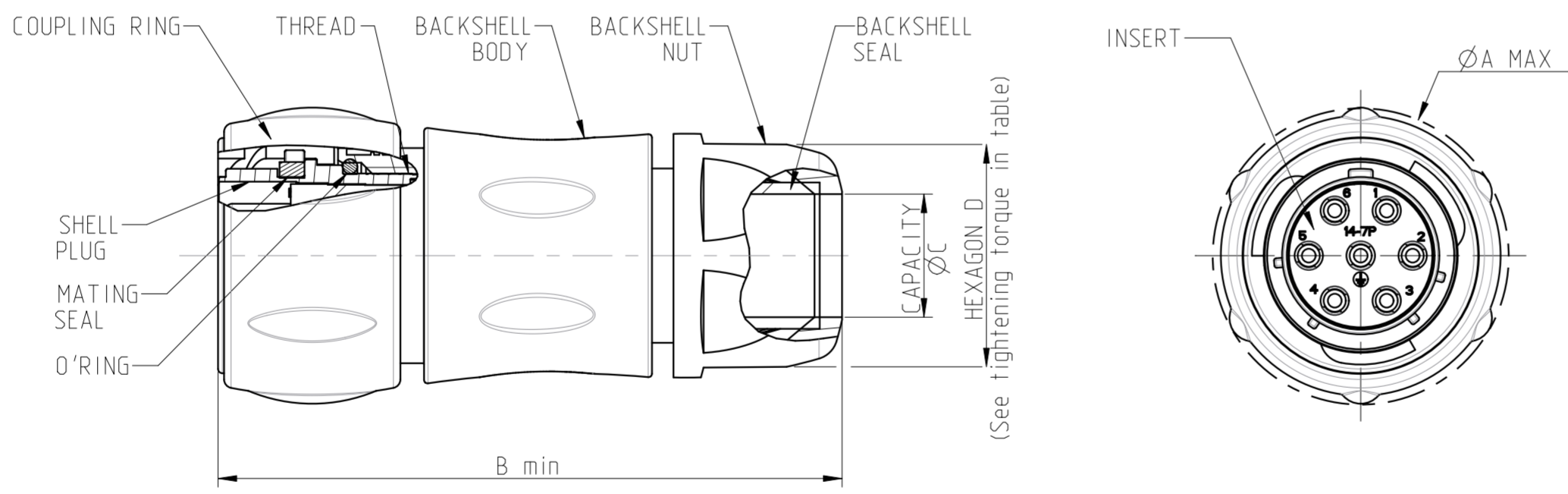

| Country | Jurisdiction & Control List |
|---------|-----------------------------|
| FR      | NOT LISTED                  |

SOURIAU shall not be liable for any non-conformity or damage due to a use of the Products which does not comply with the Specifications issued by either of the Parties or by a third party (professional recommendation, technical notice.)

P/N : CROSS REF TABLE

|                    |            |   |    |    |   |   |     |                  |                      |
|--------------------|------------|---|----|----|---|---|-----|------------------|----------------------|
| BASIC SERIES       | UTGX       | 6 | JC | 14 | 7 | P | SCR | *P/N for example |                      |
| SHELL TYPE         | 6 Plug     |   |    |    |   |   |     |                  |                      |
| RACCORD            | JC         |   |    |    |   |   |     |                  |                      |
| SHELL SIZE         | 12<br>14   |   |    |    |   |   |     |                  |                      |
| INSERT ARRANGEMENT | See NOTA 2 |   |    |    |   |   |     | TYPE OF CONTACTS | P: MALE<br>S: FEMALE |

| SHELL SIZE | MAX  | min  | STANDARD | REDUCING SEAL (NOTA.3) | HEXAGON backshell nut |                         | MAX   |      | ±10% (g.) |
|------------|------|------|----------|------------------------|-----------------------|-------------------------|-------|------|-----------|
|            | ØA   | B    | ØC       |                        | D                     | Tightening torque (N.m) | E1    | E2   | MASS      |
| 12         | 29.7 | 66.7 | 5 / 12   | 3 / 9                  | 24                    | 2                       | 15.1  | 22.8 | 40        |
| 14         | 34.6 | 71.5 | 7 / 14   | 5 / 12                 | 26                    | 2.5                     | 18.95 | 26.7 | 55        |

DETAIL CONTACT

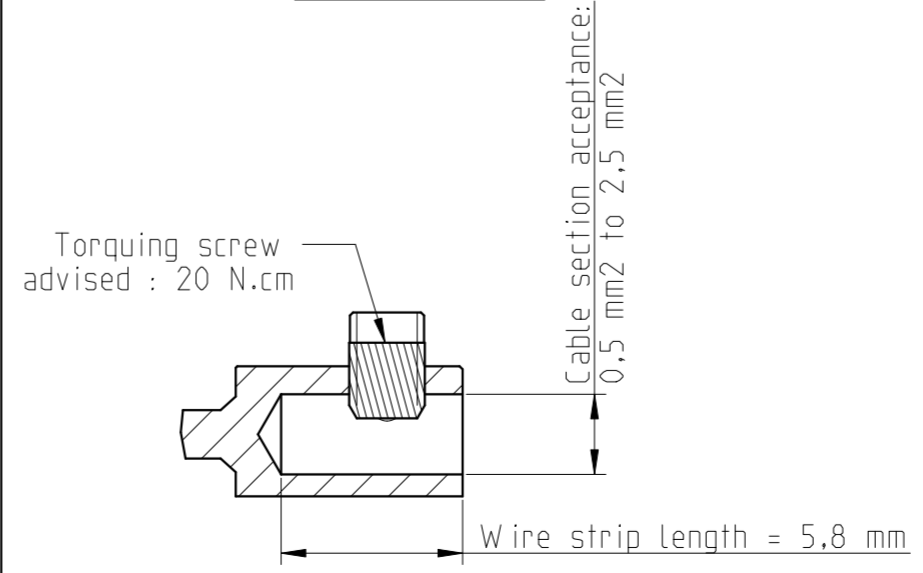

|                         |          |  |   |
|-------------------------|----------|--|---|
| A                       | 10/05/19 | New drawing  | 25253D  |
| ISS                     | DATE     | Latest modification - by:  | MOD N°  |
| Designed by: LANDAIS.PE |          | Date: 10/05/19   | CUSTOMER DRAWING  |
| TITLE                   |          | PLUG T6 WITH BACKSHELL JC AND SCREW CONTACT - SIZE 12 & 14<br>UTGX CONNECTOR |   |
| Scale                   | 3/2      | Dimensions in mm<br>General Linear<br>Tolerances:<br>± 0.2                   | NPRDS / PROJECT<br>GBB  |
|                         |          | www.esterline-connection-technologies.com                                    | This document is the property of SOURIAU. It must not be reproduced or communicated without permission. |
| FORMAT                  | A2       | SOURIAU DRG N°<br>UTGX-0006A-C   | SHEET<br>1 / 2  |

A.3: Validé

MASS ± 5% -- g

8

7

6

5

4

3

2

1

H G F E D C B A

8

7

6

5



4

3

2

1

P/N :

|   |   |  |  |
|---|---|--|--|
| A   |   |  |  |
| ISS   | DATE  | Latest modification - by:                                  | MOD N°   |
| Designed by:  |   | Date: 1  | CUSTOMER DRAWING   |
| TITLE   |   | PLUG T6 WITH BACKSHELL JC AND SCREW CONTACT - SIZE 12 & 14 |  |
| Scale   |  | Dimensions in mm<br>General Linear<br>Tolerances:<br>± --  | NPRDS / PROJECT<br>GBB   |
|  |   | www.souriau.com  | This document is the property of<br>SOURIAU<br>It must not be reproduced or<br>communicated without permission |
| FORMAT  | SOURIAU DRG N°<br>UTGX-0006A-C  |  | SHEET<br>2 / 2   |

|         |                             |
|---------|-----------------------------|
| Country | Jurisdiction & Control List |
| FR      | NOT LISTED                  |

SOURIAU shall not be liable for any non-conformity or damage due to a use of the Products which does not comply with the Specifications issued by either of the Parties or by a third party (professional recommendation, technical notice.)

H G F E D C B A