

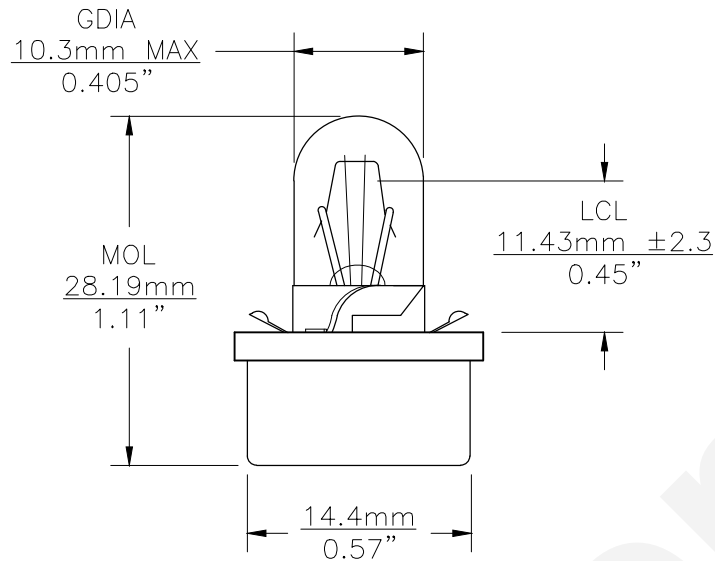

PART NO.	BASE TYPE	DESIGN VOLTS	DESIGN AMPS	MSCD	FILAMENT TYPE	AVERAGE LIFE HOURS
PC168	Printed Circuit Socket	14.0V	0.35±10%	3.0±20%	C-2F	1,500

REVISIONS			
REV #	DESCRIPTION	DATE	APPROVED
1	ISSUED	01/25/2005	D.C.
2	ADDITIONAL SPECIFICATIONS	12/12/2012	D.C.
3	ADDITIONAL INNER DIAMETER (15.0mm)	05/09/2013	S.L.
4	ADDITIONAL VIEW (BOTTOM VIEW OF BASE)	04/06/2016	R.M.

SOCKET COLOR: BLUE



0° VIEW

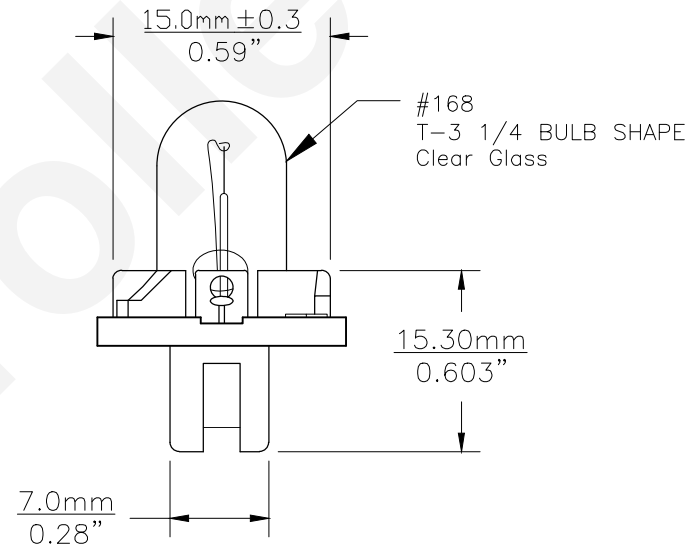

90° VIEW

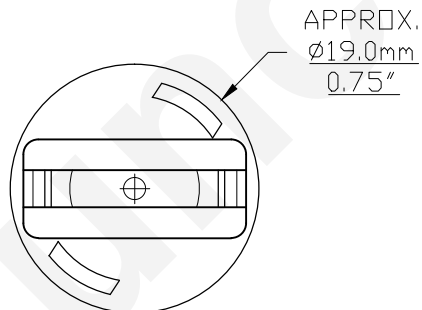

BASE BOTTOM VIEW

Note: Made according to SAE specifications



UNLESS OTHERWISE SPECIFIED: DIMENSIONS ARE IN INCHES TOLERANCES		CEC INDUSTRIES LTD	
DECIMALS	ANGULAR	599 BOND STREET LINCOLNSHIRE, IL 60069	
.XX ± .05	± 0.5°		
.XXX ± .010			
FRACTIONAL	±1/64		
DRAWN DENNIS CLARK	DATE 01/25/2005	TITLE LIGHT BULB NO. PC168	
CHECKED	SIZE A	FSCM NO.	DWG NO. PC168
DESIGN	SCALE	PLOT SCALE	REV 4
MATERIAL	FILE PC168.pdf	SHEET 1 OF 1	
		DRAWING NOT TO SCALE	