

MTR. Weldable latch clamps

Steel



- 1
- 2
- 3
- 4
- 5
- 6
- 7
- 8
- 9
- 10
- 11
- 12
- 13
- 14
- 15
- 16
- 17
- 18

MATERIAL

Black coated weldable steel.

SHANK

Ground and hardened steel.

PULLING HOOK

Natural steel.

OSCILLATING PIN AND NUTS

Natural steel.

STANDARD EXECUTIONS

- **MTR.1500**: with clamping hole by removable tube.
- **MTR.1510**: with clamping lever.

FEATURES AND APPLICATIONS

All articulated joints are lubricated with special grease.
 MTR. latch clamps are particularly suitable for applications on moulds of plastic products and rotational.
 The small dimensions of MTR.1500 execution greatly reduces the possibility of accidental damage. In addition, this execution allows the operability of the locking through a removable tube always cold, even when the mould on which the tool is used is just out of the oven.
 The position of the pulling hook can be adjusted in length according to the specific applications.

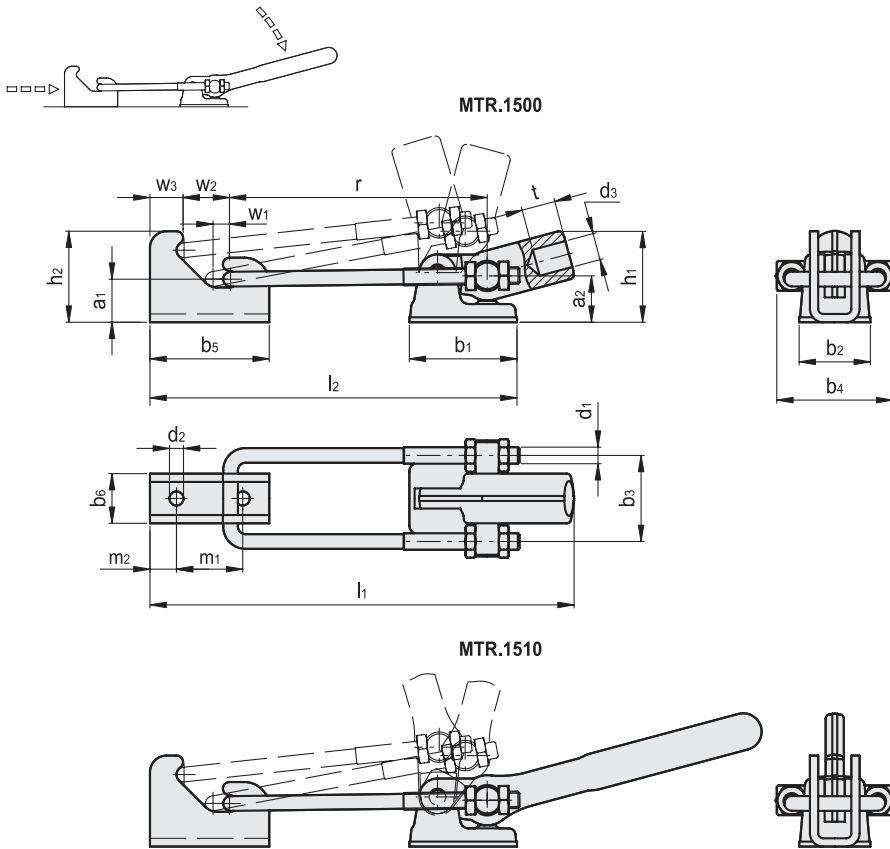

METRIC

Code	Description	a1	a2	b1	b2	b3	b4	b5	b6	d1	d2	d3	h1	h2	l1	l2	m1	m2	r	t	w1	w2	Stroke w3	FH [N]*	⚖️
GG.AL750	MTR.1500-T2S	26	28	65	43	52	70	72	30	M10	8.5	18	55	55	220	186	40	16	120	30	10.5	28	25	13000	1234
GG.AL755	MTR.1510-T2S	26	28	65	43	52	70	72	30	M10	8.5	-	81	55	334	186	40	16	120	-	10.5	28	25	13000	1320

* Holding force.

Toggle clamps