

DATA SHEET



NE1619
HECETA4
Temperature and voltage monitor

Product data sheet
Supersedes data of 2004 May 10

2004 Oct 05

HECETA4 Temperature and voltage monitor

NE1619

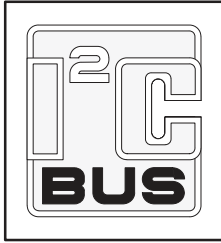

GENERAL DESCRIPTION

The NE1619 is designed for monitoring the temperatures and supply voltages of microprocessor-based systems by measuring those parameters and comparing the readings with programmable limits. The device provides five possible analog inputs, a remote temperature sensor input and on-board local temperature sensor. The device also monitors its own power supply and provides digital inputs for the Pentium/PRO power supply ID code.

The device communicates with the system controller via an SMBus (System Management bus) by which it can be programmed for operation and data collection. Readings come from conversions of the on-board A-to-D converter which cycles through all measurements in sequence in approximately one second when the conversion is started. The device includes a number of registers to store data of the device configuration, status, readings and limits. Except for the temperature-related data which are in 8-bit digital 2's complement format, all the data are in 8-bit digital straight format.

FEATURES

- Monitor local and remote temperatures
- Temperature accuracy of ± 2 °C for local, and ± 3 °C for remote channel
- Temperature resolution of 1 °C
- 2.8 V to 5.5 V supply range
- Monitor different power supplies: 12 V, 5 V, 3.3 V, 2.5 V, V_{CCP} , V_{DD}
- V_{IN} accuracy of $\pm 2\%$ of full scale
- Differential non-linearity of ± 1 LSB
- No calibration required
- Programmable temperature and voltage limits for alarms
- Programmable Reset low state pulse output
- SMBus 2-wire serial interface
- Small 16-lead SSOP (QSOP) package
- Compatible with Intel "Heceta 4" specification and reference designs utilizing it
- ESD protection exceeds 2000 V HBM per JESD22-A114, 250 V MM per JESD22-A115 and 1000 V CDM per JESD22-C101
- Latch-up testing is done to JESDEC Standard JESD78 which exceeds 100 mA

APPLICATIONS

- System thermal and hardware monitor
- Desktop computers
- Notebook computers
- Industrial controllers
- Telecom equipment

ORDERING INFORMATION

$T_{amb} = 0^{\circ}C$ to $+125^{\circ}C$

Type number	Topside mark	Package		
		Name	Description	Version
NE1619DS	NE1619	SSOP16 (QSOP)	plastic shrink small outline package; 16 leads; body width 3.9 mm; lead pitch 0.635 mm	SOT519-1

Standard packing quantities and other packaging data are available at www.standardproducts.philips.com/packaging.

HECETA4 Temperature and voltage monitor

NE1619

PINNING

Pin Configuration

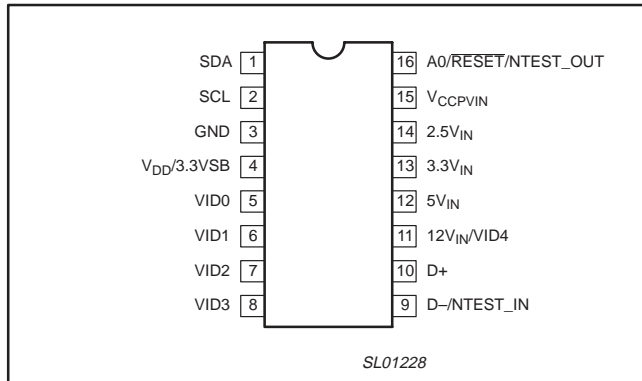

Figure 1. Pin configuration

Pin Description

PIN #	SYMBOL	FUNCTION DESCRIPTION
1	SDA	Digital I/O. SMBus serial bi-directional data. Open-drain output.
2	SCL	Digital Input. SMBus serial clock input.
3	GND	Ground. To be connected to system ground.
4	V _{DD} /3.3VSB	Power supply. Can be connected to +3.3 V standby power if monitoring in low power states is required. This pin also serves as the analog input to monitor the V _{DD} voltage level.
5	VID0	Digital Input. For Voltage ID readouts from the processor. This value is read into the VID status register (LSB bit).
6	VID1	Digital Input. For Voltage ID readouts from the processor. This value is read into the VID status register.
7	VID2	Digital Input. For Voltage ID readouts from the processor. This value is read into the VID status register.
8	VID3	Digital Input. For Voltage ID readouts from the processor. This value is read into the VID status register.
9	D-/NTEST_IN	Analog/Digital Input. This pin is connected to the negative terminal of the remote temperature sensor for analog input. If this pin is held high at power-up, for digital input, it enables the NAND-TREE test mode.
10	D+	Analog Input. This pin is connected to the positive terminal of the remote temperature sensor.
11	12V _{IN} /VID4	Analog/Digital Input. Defaults at power-up to analog input for monitoring the +12 V supply. This pin is programmable to be a digital input for voltage ID readouts from the processor. Its state is read into the VID4 status register.
12	5V _{IN}	Analog Input. For monitoring the +5 V supply.
13	3.3V _{IN}	Analog Input. For monitoring the +3.3 V supply.
14	2.5V _{IN}	Analog Input. For monitoring the +2.5 V supply.
15	V _{CCPVIN}	Analog Input. For monitoring the processor voltage supply (0 to 3.0 V)
16	A0/RESET/NTEST_OUT	Digital I/O. At power-up, the logic input of this pin defines the LSB bit of the device slave address. This pin can be configured to give a low pulse reset output of 20ms minimum. This pin also functions as the output in the NAND-TREE test mode.

HECETA4 Temperature and voltage monitor

NE1619

FUNCTIONAL BLOCK DIAGRAM

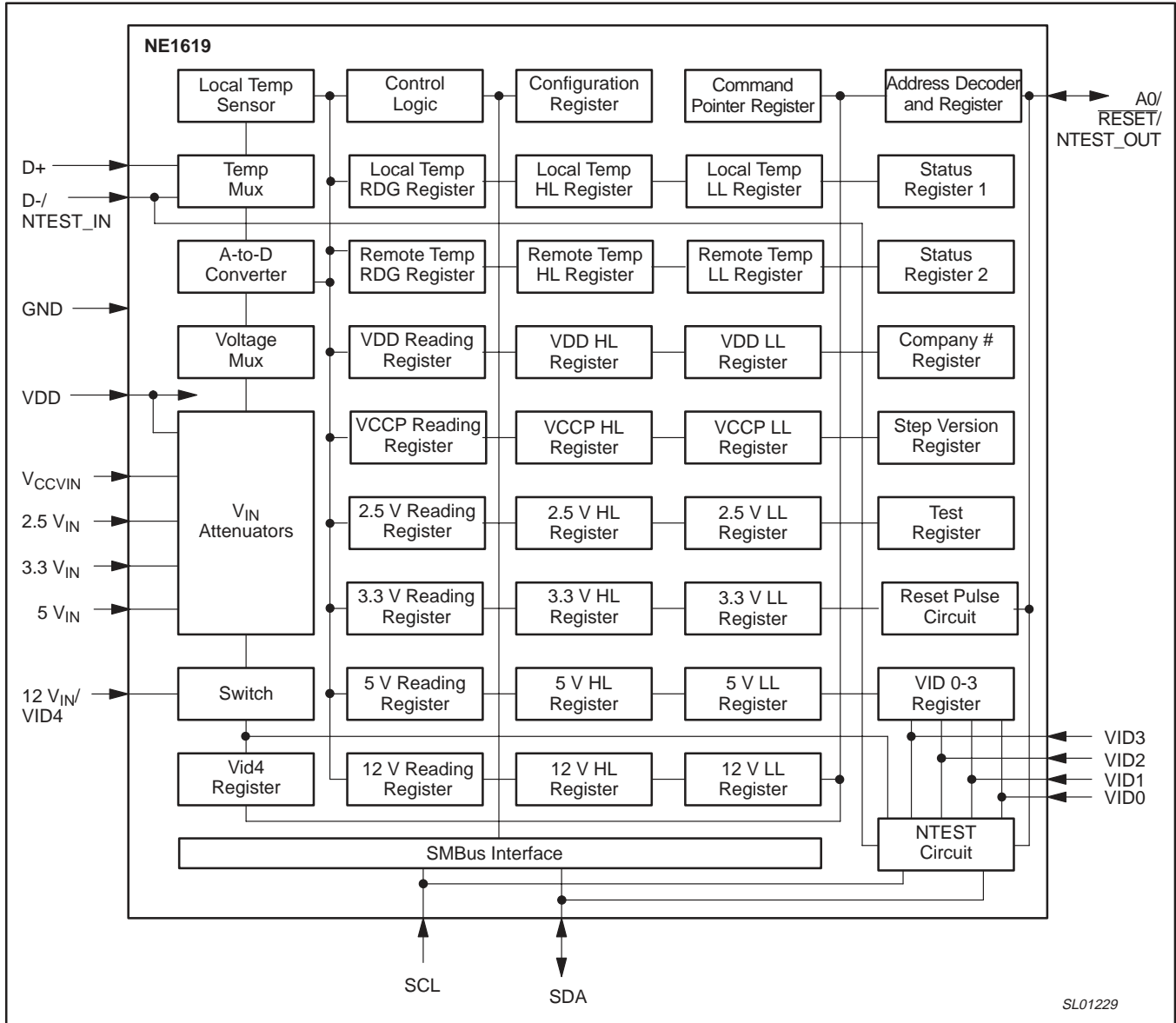

Figure 2. Functional block diagram

HECETA4 Temperature and voltage monitor

NE1619

TYPICAL APPLICATION CIRCUIT

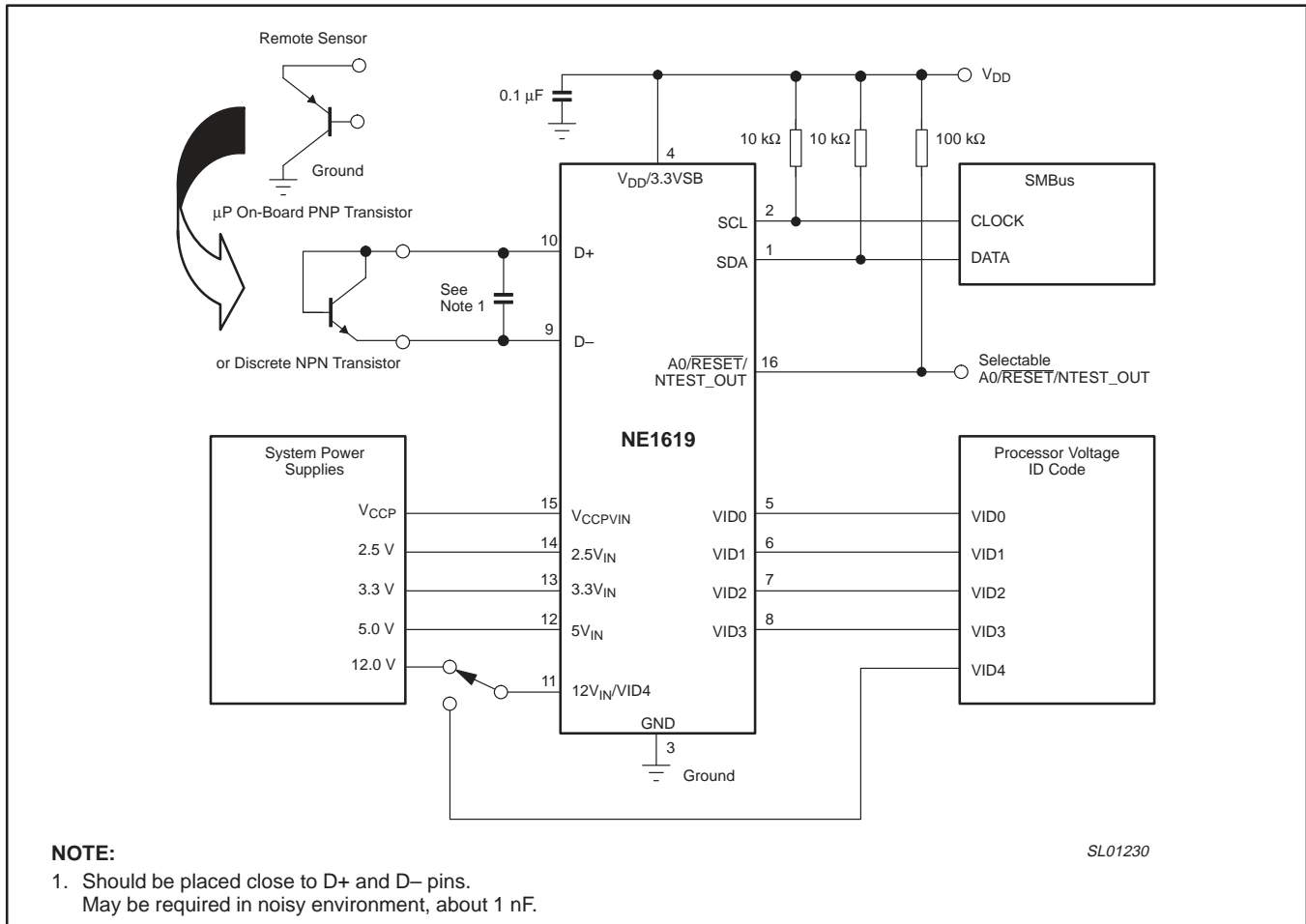

Figure 3. Typical application circuit

ABSOLUTE MAXIMUM RATINGS

PARAMETER	MIN.	MAX.	UNIT
V _{DD} to GND	-0.3	6	V
12V _{IN} to GND	-0.3	18	V
5V _{IN} , 3.3V _{IN} , 2.5V _{IN} , V _{CCP} to GND	-0.3	6	V
Other pins to GND	-0.3	V _{DD} +0.3	V
Input current at any pin	-5	5	mA
Package input current	-20	20	mA
Operating temperature range	0	+125	°C
Maximum junction temperature	-	+150	°C
Storage temperature range	-65	+150	°C

HECETA4 Temperature and voltage monitor

NE1619

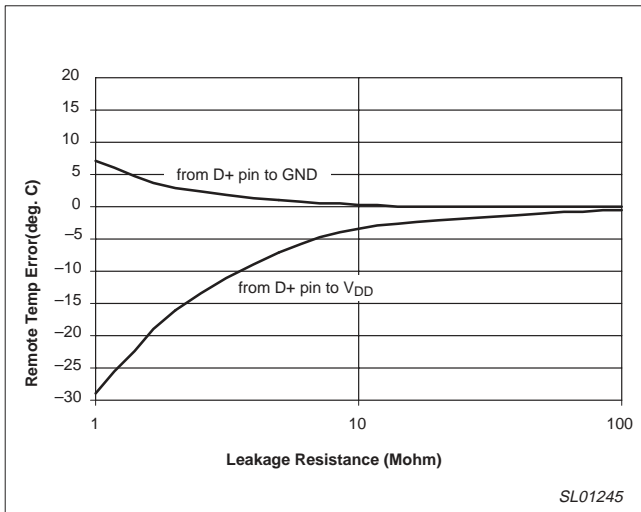

Figure 4. Temp Error versus PC Board Leakage Resistance

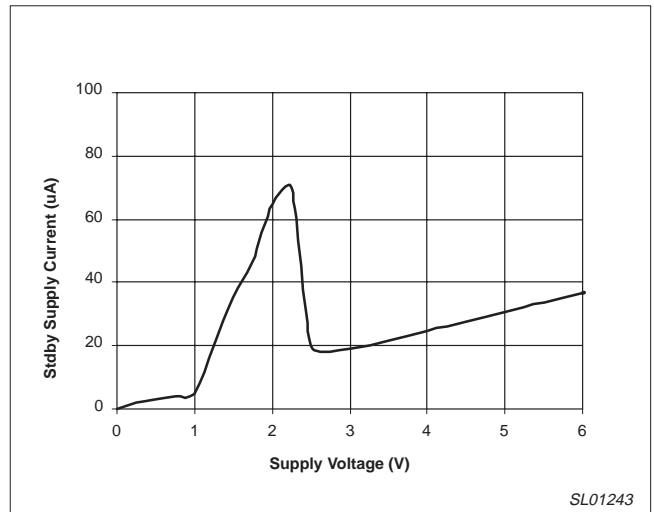

Figure 6. Standby Current versus Supply Voltage

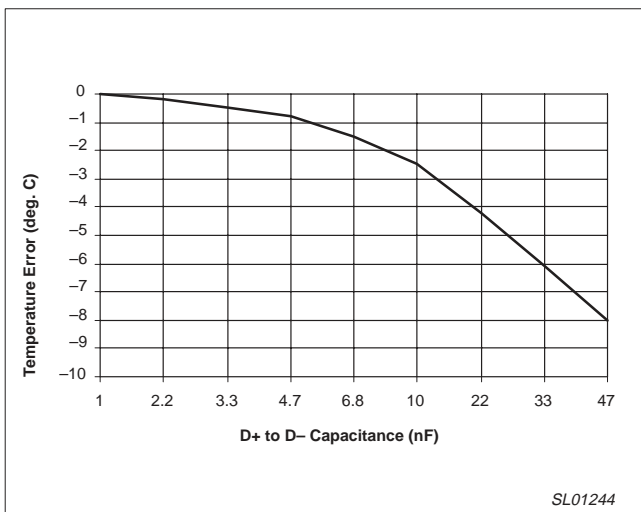

Figure 5. Temp Error versus D+D- Capacitance

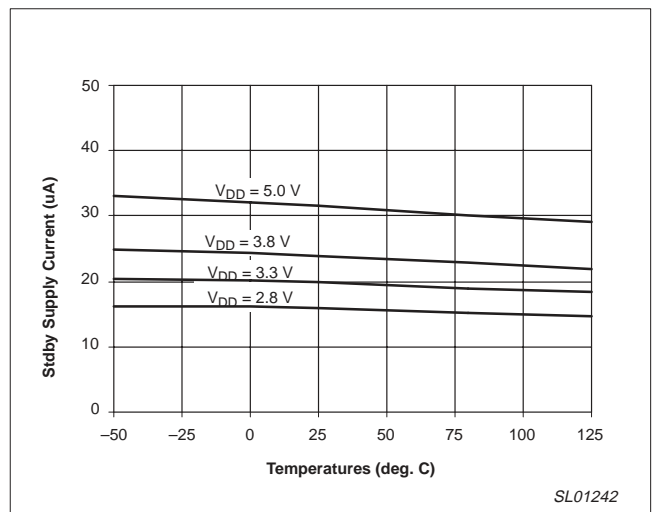

Figure 7. Standby Current versus Temperature

HECETA4 Temperature and voltage monitor

NE1619

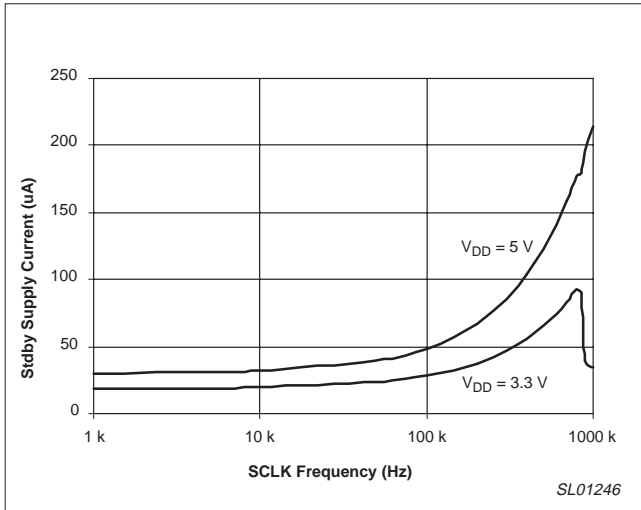

Figure 8. Standby Current versus SCLK Frequency

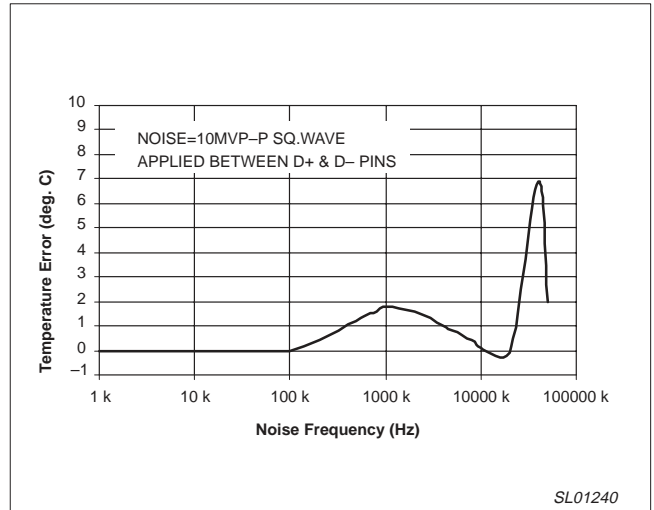

Figure 10. Temp error versus Different Mode Noise Frequency

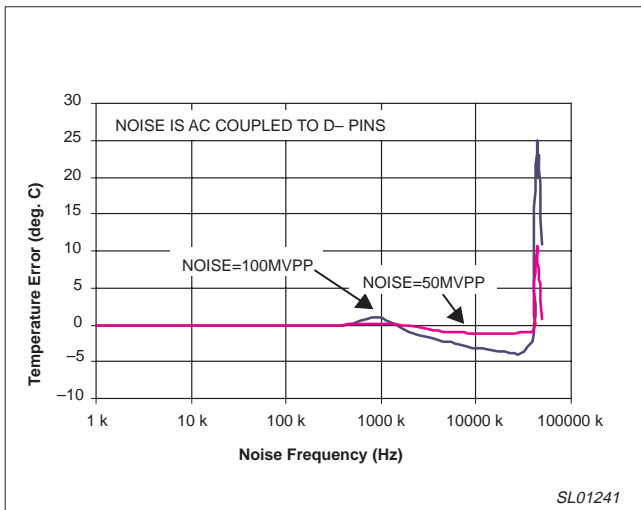

Figure 9. Temp Error versus Common Mode Noise

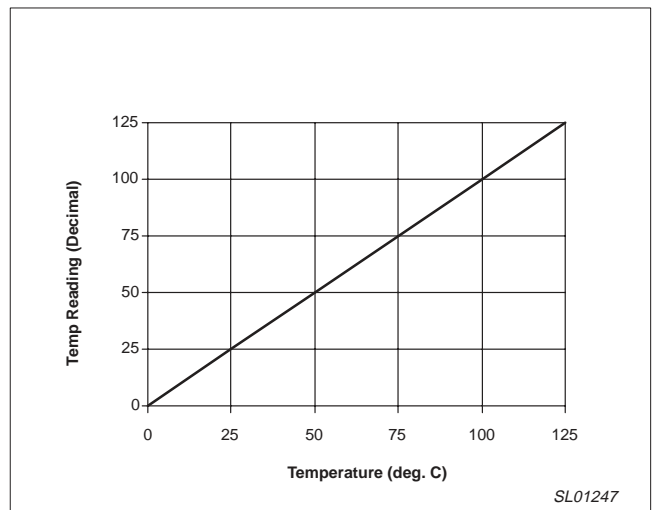

Figure 11. Relationship between Temperature and Temp reading

HECETA4 Temperature and voltage monitor

NE1619

DC ELECTRICAL CHARACTERISTICS $V_{DD} = 3.3\text{ V}$ (see Note 4); $T_{amb} = 0\text{ °C}$ to $+125\text{ °C}$ unless otherwise specified.

SYMBOL	PARAMETER	CONDITION	MIN.	TYP.	MAX.	UNIT
V_{DD}	Supply voltage		2.8	3.3	5.5	V
I_{DD}	Supply current	Standby mode	–	100	–	μA
I_{DD}	Supply current	Operating mode	–	250	500	μA
t_C	Total monitoring cycle time ¹	All conversions	–	0.25	0.50	sec
T_R	Temperature resolution	Local and Remote	–	± 1.0	–	$^{\circ}\text{C}$
T_{AI}	Internal temperature accuracy	$T_{amb} = 25\text{ °C}$	–	–	± 2.0	$^{\circ}\text{C}$
		$T_{amb} = 0\text{ °C}$ to $+120\text{ °C}$	–	–	± 3.0	$^{\circ}\text{C}$
T_{AE}	External temperature accuracy	$T_{amb} = 25\text{ °C}$	–	–	± 3.0	$^{\circ}\text{C}$
		$T_{amb} = 0\text{ °C}$ to $+120\text{ °C}$	–	–	± 5.0	$^{\circ}\text{C}$
I_S	Remote source current	High level	–	100	–	μA
		Low level	–	10	–	μA
Voltage-to-Digital converter ($12V_{IN}$, $5V_{IN}$, $3.3V_{IN}$, $2.5V_{IN}$, V_{CCP}, V_{DD})						
VUE	Unadjusted error		–	–	± 2.0	%FS
VDNL	Differential non-linearity error		–	± 1.0	–	LSB
VRIN	V_{IN} input resistance		100	200	–	$\text{k}\Omega$
VPSS	V_{IN} power supply sensitivity		–	± 1.0	–	%/V
Digital output (SDA, A0²)						
V_{OH}	Output High voltage	$I_{OUT} = -3.0\text{ mA}$, $V_{DD} = 2.8\text{ V}$	–	–	2.4	V
V_{OL}	Output Low voltage	$I_{OUT} = 3.0\text{ mA}$, $V_{DD} = 3.8\text{ V}$	0.4	–	–	V
I_{OH}	Output High leakage current	$V_{OUT} = V_{DD}$	–	0.1	10.0	μA
SMB digital input voltages (SDA, SCL)						
V_{IH}	Input High voltage		–	–	$0.6V_{DD}$	V
V_{IL}	Input Low voltage		–	–	$0.3V_{DD}$	V
Digital input voltages (A0, VID0–4, NT_IN³)						
V_{IH}	Input High voltage		–	–	2.0	V
V_{IL}	Input Low voltage		0.4	–	–	V
Digital input current (all digital inputs)						
I_{IH}	Input High current	$V_{IN} = V_{DD}$	–1.0	–	–	μA
I_{IL}	Input Low current	$V_{IN} = \text{GND}$	–	–	1.0	μA
C_{IN}	Input capacitance		–	20.0	–	pF

NOTES:

- Total monitoring cycle time includes all temperature conversions and all voltage conversions.
- When A0 is selected as output in NAND-TREE test mode.
- When D– is selected as input in NAND-TREE test mode.
- Operating the device at 2.8 V to 5.5 V is allowed, but parameter values in characteristics table are not guaranteed.

HECETA4 Temperature and voltage monitor

NE1619

SMBus INTERFACE AC CHARACTERISTICS

$V_{DD} = 3.3\text{ V}$, $T_{amb} = 0\text{ }^{\circ}\text{C}$ to $+125\text{ }^{\circ}\text{C}$ unless otherwise specified.

SYMBOL	PARAMETER	CONDITION	MIN.	TYP.	MAX.	UNIT
t_{SCL}	SCL clock frequency		–	–	400	kHz
t_{BUF}	SMBus free time		4.7	–	–	μs
t_{LOW}	SCL Low time		4.7	–	–	μs
t_{HIGH}	SCL High time		4.0	–	–	μs
$t_{SU:STA}$	Start set-up time		100	–	–	ns
$t_{HD:STA}$	Start hold time		100	–	–	ns
$t_{SU:STO}$	Stop set-up time		4.0	–	–	μs
$t_{SU:DAT}$	Data set-up time		250	–	–	ns
$t_{HD:DAT}$	Data hold time		0	–	–	ns
t_F	Fall time		–	–	1.0	μs

NOTE:

1. These specifications are guaranteed by design and not tested in production.

TIMING DIAGRAM

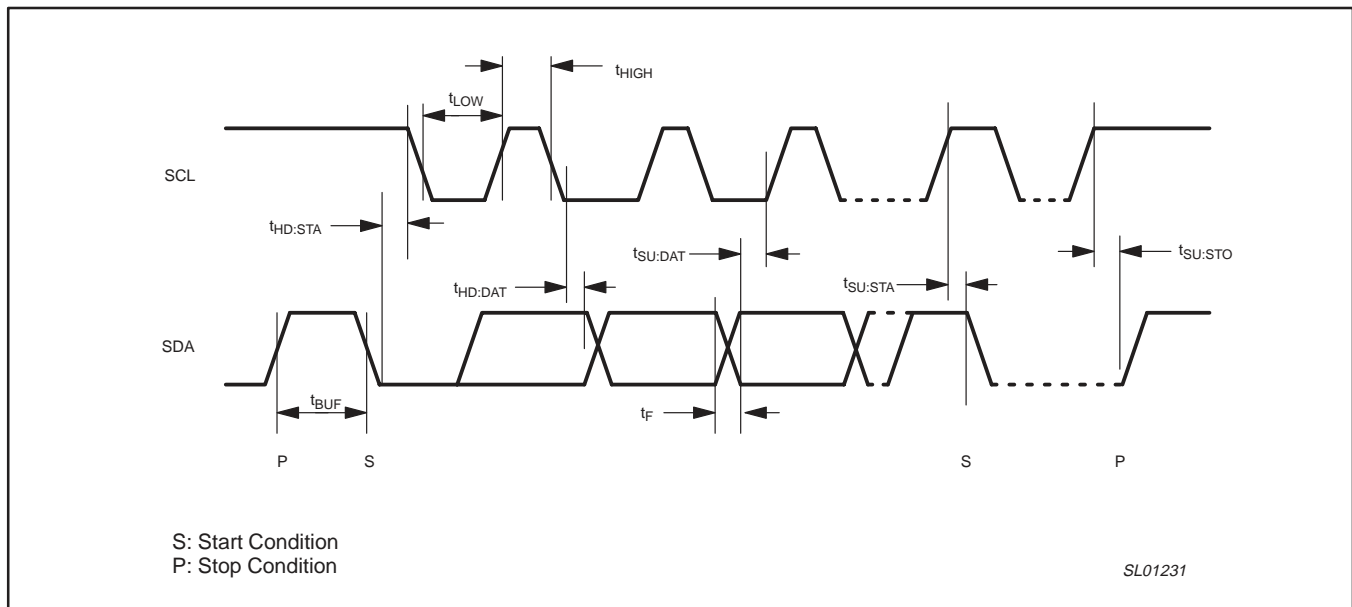

HECETA4 Temperature and voltage monitor

NE1619

Table 1. List of registers

NAME	COMMAND OR ADDRESS	R/W	POR STATE	DESCRIPTION
CR	40h	R/W	0000 1000	Configuration register
SR1	41h	Read only	0000 0000	Status register #1
SR2	42h	Read only	0000 0000	Status register #2
VID	47h	Read only	0000 xxxx	VID register, xxxx = VID3–VID0
VID4	49h	Read only	1000 000x	VID4 register, x = VID4
CID	3Eh	Read only	1010 0001	Company number
SID	3Fh	Read only	0010 0001	Stepping version number
TEST	15h	R/W	N/A	Manufacturer test register
2.5VR	20h	Read only	N/A	2.5V _{IN} reading register
VCCPR	21h	Read only	N/A	V _{CCPVIN} reading register
3.3VR	22h	Read only	N/A	3.3V _{IN} reading register
5VR	23h	Read only	N/A	5V _{IN} reading register
12VR	24h	Read only	N/A	12V _{IN} reading register
VDDR	25h	Read only	N/A	V _{DD} reading register
ETR	26h	Read only	N/A	External or remote temperature reading register
ITR	27h	Read only	N/A	Internal or local temperature reading register
2.5VHL	2Bh	R/W	0000 0000	2.5V _{IN} high limit register
2.5VLL	2Ch	R/W	0000 0000	2.5V _{IN} low limit register
VCCPHL	2Dh	R/W	0000 0000	V _{CCPVIN} high limit register
VCCPLL	2Eh	R/W	0000 0000	V _{CCPVIN} low limit register
3.3VHL	2Fh	R/W	0000 0000	3.3V _{IN} high limit register
3.3VLL	30h	R/W	0000 0000	3.3V _{IN} low limit register
5VHL	31h	R/W	0000 0000	5V _{IN} high limit register
5VLL	32h	R/W	0000 0000	5V _{IN} low limit register
12VHL	33h	R/W	0000 0000	12V _{IN} high limit register
12VLL	34h	R/W	0000 0000	12V _{IN} low limit register
VDDHL	35h	R/W	0000 0000	V _{DDVIN} high limit register
VDDL	36h	R/W	0000 0000	V _{DDVIN} low limit register
ETHL	37h	R/W	0000 0000	External or remote temperature high limit register
ETLL	38h	R/W	0000 0000	External or remote temperature low limit register
ITHL	39h	R/W	0000 0000	Internal or local temperature high limit register
ITLL	3Ah	R/W	0000 0000	Internal or local temperature low limit register

HECETA4 Temperature and voltage monitor

NE1619

Table 2. Configuration Register (CR, 40h, default = 0000 1000)

BIT	NAME	R/W	DESCRIPTION
0	START	R/W	Logic 1 enables startup of monitor device, logic 0 places the device in standby mode. Power-up default = 0. At startup, limit checking functions and scanning begins. Note, all High and Low limits should be set into the ASIC prior turning on this bit.
1	Reserved	Read	Power-up default = 0.
2	Reserved	Read	Power-up default = 0.
3	Reserved	Read	Power-up default = 1.
4	RESET	R/W	Setting this bit generates a minimum 20ms low pulse on the Reset pin, if the reset function is enabled. Power-up default = 0.
5	12V _{IN} /VID4 SELECT	R/W	Selects whether pin 11 acts as a 12 volt analog input monitoring pin, or as a VID[4] input. This pin defaults to the 12 volt analog input. Power-up default = 0.
6	Reserved	Read	Power-up default = 0.
7	Initialization	R/W	Logic 1 restores power-up default values to the configuration register and the status registers. This bit automatically clears itself. Power-up default = 0.

Table 3. Status Register 1 (SR1, 41h, default = 0000 0000)

BIT	NAME	R/W	DESCRIPTION
0	+2.5V_ERROR	Read	A one indicates 2.5V _{IN} High or Low limit has been exceeded.
1	VCCP_ERROR	Read	A one indicates V _{CCPVIN} High or Low limit has been exceeded.
2	+3.3V_ERROR	Read	A one indicates 3.3V _{IN} High or Low limit has been exceeded.
3	+5V_ERROR	Read	A one indicates 5V _{IN} High or Low limit has been exceeded.
4	Internal Temp Error	Read	A one indicates internal or local temp High or Low limit has been exceeded.
5	External Temp Error	Read	A one indicates external or remote temp High or Low limit has been exceeded.
6	Reserved	Read	
7	Reserved	Read	

Table 4. Status Register 2 (SR2, 42h, default = 0000 0000)

BIT	NAME	R/W	DESCRIPTION
0	+12V_ERROR	Read	A one indicates 12V _{IN} High or Low limit has been exceeded.
1	VDD_ERROR	Read	A one indicates V _{DD} High or Low limit has been exceeded.
2	Reserved	Read	Undefined.
3	Reserved	Read	Undefined.
4	Reserved	Read	Undefined.
5	Reserved	Read	Undefined.
6	Remote Diode Fault	Read	A one indicates either a short or open circuited fault on the remote thermal diode inputs.
7	Reserved	Read	Undefined.

Table 5. VID (VID, 47h, default = 0000 VID[3:0])

BIT	NAME	R/W	DESCRIPTION
0–3	VID[0:3]	Read	The VID[0:3] inputs from Pentium/PRO power supplies ID to indicate the operating voltage (e.g. 1.5V to 2.9V). Power-up default = VID[0:3].
4–6	Reserved	Read	Undefined.
7	RESET ENABLE	Read	When set to 1, enables the RESET pin output function. This bit defaults to 0 at Power-up and enables addressing function.

Table 6. VID4 (VID4, 49h, default = 1000 000VID[4])

BIT	NAME	R/W	DESCRIPTION
0	VID4	Read	VID4 input, if selected, from Pentium/PRO power supplied ID. Power-up default = 0 and pin 11 is not selected for VID4.
1–7	Reserved	Read	Power-up default = 1000 000

HECETA4 Temperature and voltage monitor

NE1619

FUNCTIONAL DESCRIPTION

SMBus serial interface

The NE1619 can be connected to a compatible 2-wire serial interface SMBus as a slave device under the control of a master device or controller, using two device terminals SCL and SDA. The controller will provide a clock signal to the device SCL pin and write/read data to/from the device through the SDA pin.

Data of 8-bit digital byte or word are used for communication between the controller and the device.

Notice that external pull-up resistors, about 10 kΩ, are needed for the two terminals SCL and SDA.

Slave address

The NE1619 slave address on the SMBus is defined by the hardware connection applied to the device pin 16. At power-up this pin is automatically reset to its address sensing function A0. This logic input will set up the value of the LSB bit of the 7-bit address. Because A0 is a two-level digital input and the other 6 bits of the address are predefined to 010110, only two slave addresses can be used as listed below for the device:

Table 7.

A0 connection (Pin 16)	Slave address
GND	0101100
V _{DD}	0101101

Because the logic is sampled and latched into the device storage only at power-up, the device pin 16 can be programmed for different functions while power is on without effecting the address definition.

Registers

The NE1619 contains a number of registers, as listed in Table 1, in order to store data of the device setup and operation results. The table indicates the command value and read/write capability of each register for SMBus communication and also the power-up default values for some registers. It includes:

- Configuration register to provide control and configuration as well as initialization the NE1619,
- Status registers to provide the flags resulting from limit comparisons,
- Reading registers to store results of measurements,
- Limit registers to store programmable limit data,
- ID and test registers.

Data are stored in registers by 8-bit digital byte, either in 2's complement format for temperature-related data or in straight format for others. Writing and reading registers will be done on the SMBus by a controller using the SMBus protocols that will be described more in the last section of this functional description. Notice that attempting to write to a "Read only" register will produce an invalid result.

Power-on reset

When the power is applied to the NE1619, also called hardware reset, the registers are reset to their default value, if defined, as shown in Table 1. The content of registers which have indeterminate default value such as reading registers will be unknown. The on-board A-to-D converter is disabled and the monitoring function is not started. The device enters standby mode and draws a supply current less than 100 μA.

Because all limit registers are reset to zero, writing limits into the limits registers should usually be the first action to be performed after power-on reset.

Initialization

Initialization or software reset of the NE1619 can be initiated by setting bit 7 of the configuration register. This bit automatically clears itself after being set. The initialization performs a similar reset function to power-on reset, except that the reading and limit registers are not reset.

Starting conversion

The NE1619 monitoring function is started by setting (to 1) the START bit (bit 0) of the configuration register. The device then performs a loop of monitoring about every second. In monitoring function, the device cycles sequentially through all measurements of temperatures and voltages and also performs the comparisons between readings and limits accordingly. The inputs are sampled in this order: Remote diode temperature, Local temperature, V_{DD}V_{IN}, 12V_{IN}, 5V_{IN}, 3.3V_{IN}, 2.5V_{IN} and V_{CCP}V_{IN}.

Measured values are stored in reading registers and results of limit comparison are reflected by the state of the flag bits in the status registers. Reading and status data can be read at any time. Limit values should be written into limit registers before starting conversion to avoid false conditions of the status.

Resetting (to 0) the START bit (bit 0) of the configuration register will stop the monitoring function and put the device into its standby mode thereby reducing power consumption.

Temperature measurement

The NE1619 contains an on-chip temperature sensor to measure the local or internal temperature and provides input pins (D– and D+) to measure the remote or external temperature with the use of a remote diode-type sensor. The remote sensor should be connected to the D– and D+ pins properly.

The method of temperature measurement is based on the change of the diode V_{BE} at two different operating current levels given by:

$$\Delta V_{BE} = (KT/q) * \ln(N)$$

where:

- K: Boltzmann's constant
- T: absolute temperature in °K
- q: charge on the electron
- N: ratio of the two currents
- LN: natural logarithm

The NE1619 provides two current sources of about 10 μA and 100 μA during the measurement of the remote diode V_{BE} and the sensed voltage between two pins D– and D+ is limited within 0.25 V and 0.95 V.

The external diode should be selected to meet this current and voltage requirements. The diode-connected PNP transistor provided on the Pentium series microprocessor is typically used, or the discrete diode-connected transistor 2N3904 is recommended.

For temperature measurement, local or remote, the ΔV_{BE} is converted into digital data by the on-chip sigma-delta A-to-D converter. The result is stored in the temperature reading register and is also compared with the limits stored in the temperature limit registers in order to set the temperature flag bits in the status register as described in Table 3.

HECETA4 Temperature and voltage monitor

NE1619

Temperature data is represented by a digital 8-bit byte or word in two's complement format with a resolution of 1 °C. Theoretically, the temperature value can be from -128 °C to +127 °C but, practically, the operation range is limited to (0 °C, 120 °C). Here are some of temperature values and data:

Table 8.

TEMPERATURE VALUE (°C)	TEMPERATURE DATA
+127	0111 1111
+126	0111 1110
+100	0110 0100
+25	0001 1001
+1	0000 0001
0	0000 0000
-1	1111 1111
-25	1110 0111
-50	1100 1110

Voltage measurement

The NE1619 provides 5 analog inputs for directly monitoring the power supplies typically found in a PC or multiservice equipment, having nominal values of +2.5 V, +3.3 V, +5.0 V, +12.0 V and V_{CCP} (2.25 V). The device also monitors its own V_{DD} whose nominal value is 3.3 V. Note: at power-up, the device Pin 11 is defaulted to its 12V_{IN} function. These inputs are internally attenuated by on-chip resistor networks to the reference levels that are then multiplexed to a 8-bit Delta-Sigma A-to-D converter for converting into digital data. Each V_{IN} input is overall scaled in such a way that the decimal value of the data for its nominal voltage value is equal to 192. It means that the overall step size of the conversion for each V_{IN} is equal to $1/192$ of its nominal value. Reading data are stored in the V_{IN} reading registers and are also compared with the limits stored in the V_{IN} limit registers in order to set the voltage flag bits in the status registers as described in Tables 3 and 4.

The V_{IN} data, different from the temperature data, is represented by a digital 8-bit byte or word in straight format with a resolution LSB equal to $1/192$ of the nominal value, and has any value from 0 to 255. This is how to calculate the V_{IN} error from the V_{IN} reading at any input including V_{DD} :

Resolution in volts:	LSB = (V_{IN} nominal in volt)/192
Full scale in volts:	FS = 255 * LSB
Reading value in volts:	V_{IN} value = (decimal value of V_{IN} reading) * LSB
Reading error in volts:	V_{IN} error = (V_{IN} value) - (V_{IN} applied)
V_{IN} error in % of FS:	V_{IN} error % = 100*(V_{IN} error)/FS
Applied value < 0 results in a reading of about 0	
Applied value > FS results in a reading of about 255	

Input safety

Since the power supply voltages will appear directly at V_{IN} pins, a small external resistor, about 500 Ω, should be connected in series with each pin in order to prevent damaging the power supplies due to accidental short. These resistors are recommended but not

necessary. No external resistor-divider should be used for the V_{IN} pins because of the effect of the internal input resistors, about 140 kΩ at each pin, on the divider accuracy.

Processor Voltage ID (VID)

The NE1619 provides 5 digital pins (VID0–VID4) to read the processor voltage ID code and store it into the VID registers so that the code can be read over the SMBus:

VID register:	bit 0–bit3	reflect VID0–VID3 respectively
VID4 register:	bit 0	reflects VID4

Because the VID4 function of 12V_{IN}/VID4 pin (Pin 11) is not selected at power-up (default function of this pin is 12V_{IN}), the process of selecting this pin must be performed, if VID4 is needed, by setting (to 1) bit 5 (12V_{IN}/VID4 SELECT) of the configuration register. The default value of bit 0 of the VID4 register is 0.

The VID inputs should not be left floating because they are not internally biased. If they are not used then they should be connected to either GND or V_{DD} with resistors.

Limit data

High and Low limits for temperatures and voltages should be programmed into the limit registers using the format as described above. During monitoring cycle, the measured data is automatically compared with the limits and flag bits in the status registers are set accordingly to the results. The assignment of the status bits are listed in Tables 3 and 4.

Status registers

Results of limits comparisons are reflected by status or flag bits stored in the status register 1 and 2. If the reading is within the limits then the corresponding flag bit will be cleared to 0. Otherwise, it will be set to 1. Status data can be read over the SMBus. Notice that because the flag bits are automatically updated at every monitoring cycle, their states only reflect the last measurements.

Diode fault status

The hardware connection at the diode pins (D+ and D-) are also checked at the measurement of external temperature and the fault condition is indicated by the flag bit 6 of the status register 2. This bit is set to 1 if either short or open circuit fault is detected.

RESET output function

The NE1619 Pin 16 can be selected as a reset pulse output. When this function is selected and the reset pulse is initiated, this pin will output a single (minimum 20 ms) low state pulse.

The reset output function is selected by setting (to 1) the RESET ENABLE bit (bit 7) of the VID register. Thereafter, the reset pulse is generated whenever the RESET bit (bit 4) of the configuration register is programmed to change from 0 to 1.

Because Pin 16 becomes an open-drain output when it is selected as an output, an external pull-up resistor, about 100 kΩ is needed for the output operation. This will restrict the address function on Pin 16 to being high at power-up. Therefore, if multiple NE1619's are connected on the same bus, only one can have this function enabled at one time.

HECETA4 Temperature and voltage monitor

NE1619

NAND-tree test

A NAND tree is provided in the NE1619 for Automated Test Equipment (ATE) board level connectivity testing. The device is placed into NAND tree test mode by powering up with Pin 9 (D-/NTEST_IN) held high. In this test mode Pin 16 (A0/RESET/NTEST_OUT) becomes the NAND-tree output and all input pins become NAND-tree inputs as illustrated in Figure 12.

To perform a NAND tree test all pins should be initially driven low. Then one-by-one toggle them high (and keep them high), starting with the input closest to the output, cycling toward the farthest, the NAND tree output will toggle with each input change.

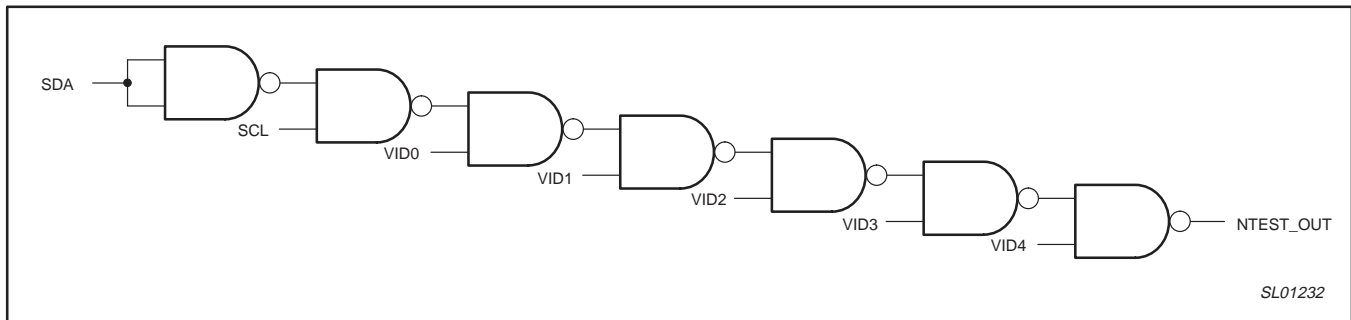

Figure 12. NAND-tree circuitry

Table 9. NAND-tree test vectors

VECTOR #	SDA	SCL	VID0	VID1	VID2	VID3	VID4	NTEST_OUT
1	L	L	L	L	L	L	L	H
2	L	L	L	L	L	L	H	L
3	L	L	L	L	L	H	H	H
4	L	L	L	L	H	H	H	L
5	L	L	L	H	H	H	H	H
6	L	L	H	H	H	H	H	L
7	L	H	H	H	H	H	H	H
8	H	H	H	H	H	H	H	L

HECETA4 Temperature and voltage monitor

NE1619

SMBus interface protocol

The NE1619 can communicate over a compatible 2-wire serial interface SMBus using the two device pins SCL and SDA. The device employs three standard SMBus protocols: Write Byte, Read Byte and Receive byte.

Data formats of those protocols are shown below with following notices:

- The SMBus controller initiates data transfer by establishing a start condition (S) and terminates data transfer by generating a stop condition (P).
- Data is sent over the serial bus in sequence of 9 clock pulses for each 8-bit data byte followed by 1-bit status of the device acknowledgement (A).

- The 7-bit slave address is replaced by the selected address of the device.
- The command byte is replaced by the selected command of the device register.
- The receive byte format is used for quickly transfer data from a reading register which was previously selected by a read.
- During the transition between start and stop conditions, data must be stable and valid when the SCL is high.

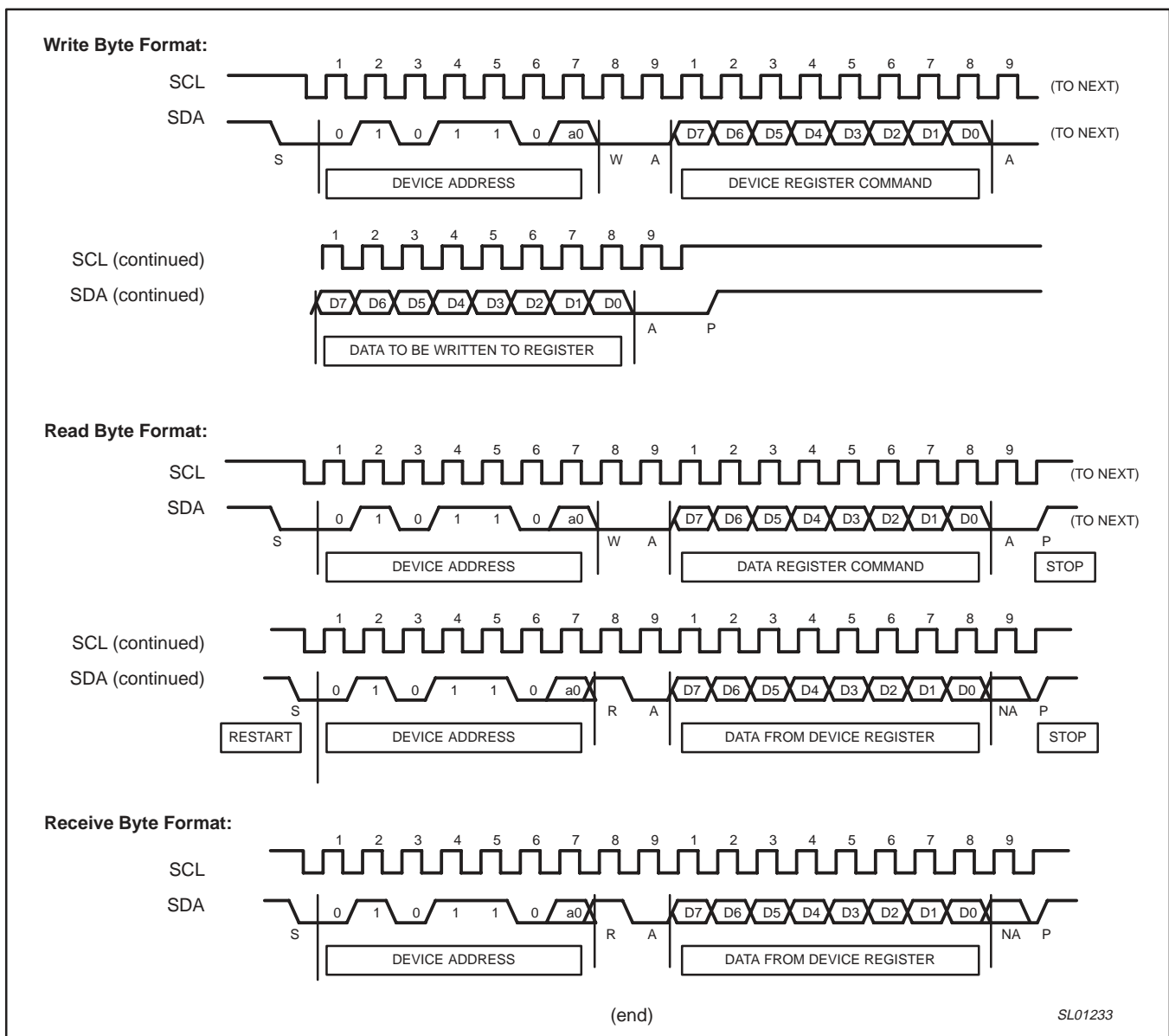

Figure 13. NE1619 SMBus interface protocols

HECETA4 Temperature and voltage monitor

NE1619

Printed Circuit Board layout considerations

Care must be taken in PCB layout to minimize noise induced at the remote temperature sensor inputs, especially in extremely noisy environments, such as a computer motherboard. Noise induced in the traces running between the device sensor inputs and the remote diode can cause temperature conversion errors. Typical sensor signal levels to the NE1619 is a few microvolts. The following guidelines are recommended:

1. Place the NE1619 as close as possible to the remote sensor. It can be from 4 to 8 inches, as long as the worst noise sources such as clock generator, data and address buses, CRTs are avoided.
2. Route the D+ and D- lines parallel and close together with ground guards enclosing them (see Figure 14).
3. Leakage currents due to PC board contamination must be considered. Error can be introduced by these leakage currents.
4. Use wide traces to reduce inductance and noise pickup. Narrow traces more readily pickup noise. The minimum width of 10 mil and space of 10 mil are recommended.
5. Place a bypass capacitor of 100 nF close to the V_{DD} pin and an input filter capacitor of 2200 pF close to the D+ and D- pins.
6. If the remote sensor is operating in a noisy environment and located several feet away from the NE1619, a shielded twisted pair cable is recommended. Make sure the shield of the cable is connected to the NE1619 ground pin, and leave the shield at the remote end unconnected. Shield connecting to ground of both ends could create a ground loop (refer to Figure 15) and defeat the purpose of the shielded cable. Also, cold soldered joints and damaged cable could introduce series resistance and result in measurement error. For instance, a 1 Ω resistance can introduce a change of temperature of about 0.5 °C.

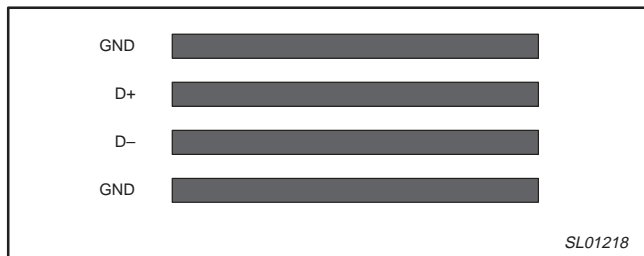

Figure 14. PCB layout for D+ and D-

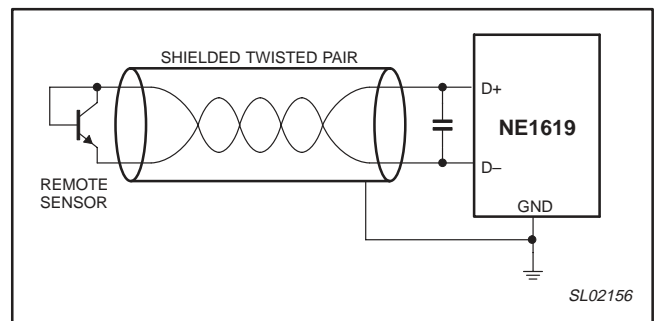

Figure 15. Using shielded twisted pair

HECETA4 Temperature and voltage monitor

NE1619

SSOP16: plastic shrink small outline package; 16 leads;
body width 3.9 mm; lead pitch 0.635 mm

SOT519-1

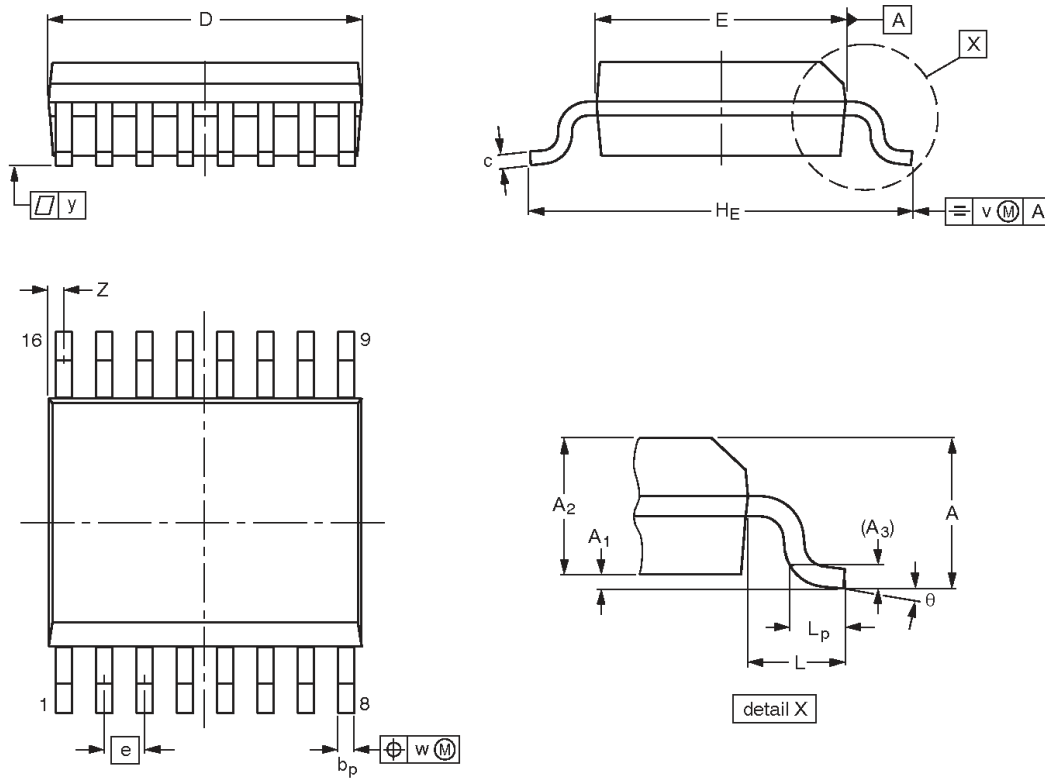

DIMENSIONS (mm are the original dimensions)

UNIT	A max.	A ₁	A ₂	A ₃	b _p	c	D ⁽¹⁾	E ⁽¹⁾	e	H _E	L	L _p	v	w	y	Z ⁽¹⁾	θ
mm	1.73	0.25 0.10	1.55 1.40	0.25	0.31 0.20	0.25 0.18	5.0 4.8	4.0 3.8	0.635	6.2 5.8	1	0.89 0.41	0.2	0.18	0.09	0.18 0.05	8° 0°

Note

1. Plastic or metal protrusions of 0.2 mm maximum per side are not included.

OUTLINE VERSION	REFERENCES				EUROPEAN PROJECTION	ISSUE DATE
	IEC	JEDEC	JEITA			
SOT519-1						-99-05-04 03-02-18

HECETA4 Temperature and voltage monitor

NE1619

REVISION HISTORY

Rev	Date	Description
4	20041005	<p>Product data sheet (9397 750 14175). Supersedes data of 2004 May 10 (9397 750 13254).</p> <p>Modifications:</p> <ul style="list-style-type: none"> ● “Features” section on page 2: add ESD and Latch-up bullets to bottom of list. ● “Ordering information” table: change temperature range from “$T{amb} = 0\text{ °C}$ to $+120\text{ °C}$” to “$T_{amb} = 0\text{ °C}$ to $+125\text{ °C}$” ● Add figure titles to Pin configuration, Functional block diagram, Typical application circuit. ● Section “Typical operating circuit” re-named to “Typical application circuit”; figure modified. ● “Absolute maximum ratings” table: change Operating temperature range maximum from $+120\text{ °C}$ to $+125\text{ °C}$ ● Figure 4 re-titled ● “DC electrical characteristics” table: add Note 4 and its reference at table description line. ● “SMBus interface AC characteristics” table: change temperature range from “$T_{amb} = 0\text{ °C}$ to $+120\text{ °C}$” to “$T_{amb} = 0\text{ °C}$ to $+125\text{ °C}$” ● Section “Printed Circuit Board layout considerations”: <ul style="list-style-type: none"> – paragraph 5: change from “Place a bypass capacitor of 10 nF close to ...” to “Place a bypass capacitor of 100 nF close to ...” – paragraph 6 re-written – add Figure 15
_3	20040510	Product data (9397 750 13254). Supersedes data of 2001 Aug 29.
_2	20010829	Product data (9397 750 08874). Supersedes data of 2000 Jul 13.
_1	20000713	Product specification (9397 750 07323).

HECETA4 Temperature and voltage monitor

NE1619



Purchase of Philips I²C components conveys a license under the Philips' I²C patent to use the components in the I²C system provided the system conforms to the I²C specifications defined by Philips. This specification can be ordered using the code 9398 393 40011.

Data sheet status

Level	Data sheet status ^[1]	Product status ^[2] [3]	Definitions
I	Objective data sheet	Development	This data sheet contains data from the objective specification for product development. Philips Semiconductors reserves the right to change the specification in any manner without notice.
II	Preliminary data sheet	Qualification	This data sheet contains data from the preliminary specification. Supplementary data will be published at a later date. Philips Semiconductors reserves the right to change the specification without notice, in order to improve the design and supply the best possible product.
III	Product data sheet	Production	This data sheet contains data from the product specification. Philips Semiconductors reserves the right to make changes at any time in order to improve the design, manufacturing and supply. Relevant changes will be communicated via a Customer Product/Process Change Notification (CPCN).

[1] Please consult the most recently issued data sheet before initiating or completing a design.

[2] The product status of the device(s) described in this data sheet may have changed since this data sheet was published. The latest information is available on the Internet at URL <http://www.semiconductors.philips.com>.

[3] For data sheets describing multiple type numbers, the highest-level product status determines the data sheet status.

Definitions

Short-form specification — The data in a short-form specification is extracted from a full data sheet with the same type number and title. For detailed information see the relevant data sheet or data handbook.

Limiting values definition — Limiting values given are in accordance with the Absolute Maximum Rating System (IEC 60134). Stress above one or more of the limiting values may cause permanent damage to the device. These are stress ratings only and operation of the device at these or at any other conditions above those given in the Characteristics sections of the specification is not implied. Exposure to limiting values for extended periods may affect device reliability.

Application information — Applications that are described herein for any of these products are for illustrative purposes only. Philips Semiconductors make no representation or warranty that such applications will be suitable for the specified use without further testing or modification.

Disclaimers

Life support — These products are not designed for use in life support appliances, devices, or systems where malfunction of these products can reasonably be expected to result in personal injury. Philips Semiconductors customers using or selling these products for use in such applications do so at their own risk and agree to fully indemnify Philips Semiconductors for any damages resulting from such application.

Right to make changes — Philips Semiconductors reserves the right to make changes in the products—including circuits, standard cells, and/or software—described or contained herein in order to improve design and/or performance. When the product is in full production (status 'Production'), relevant changes will be communicated via a Customer Product/Process Change Notification (CPCN). Philips Semiconductors assumes no responsibility or liability for the use of any of these products, conveys no license or title under any patent, copyright, or mask work right to these products, and makes no representations or warranties that these products are free from patent, copyright, or mask work right infringement, unless otherwise specified.

Contact information

For additional information please visit
<http://www.semiconductors.philips.com>. Fax: +31 40 27 24825

© Koninklijke Philips Electronics N.V. 2004
 All rights reserved. Printed in U.S.A.

Date of release: 10-04

For sales offices addresses send e-mail to:
sales.addresses@www.semiconductors.philips.com

Document order number:

9397 750 14175

Let's make things better.