

6 GHz/ 12 Gbps Clock/ Data Fanout Buffer with Internal Termination

Features

- Input Clock Frequency up to 6 GHz Typical
- Maximum Input Data Rate up to 12 Gbps Typical
- 4 pairs of differential CML outputs
- Low additive jitter, < 0.05ps (max)
- Input accepts: CML, LVDS, CML, SSTL input level
- Output to Output skew: <20ps
- Operating Temperature: -40°C to 85°C
- Power supply: 3.3V ±10% or 2.5V ±5%
- Totally Lead-Free & Fully RoHS Compliant (Notes 1 & 2)
- Halogen and Antimony Free. “Green” Device (Note 3)
- Packaging (Pb-free & Green):
 - 16-pin TQFN (ZH)

Description

The PI6C5946004 is a high-performance low-skew 1-to-4 CML clock or data fanout buffer. The inputs accept CML, LVDS, CML and SSTL signals with internal termination resistors. PI6C5946004 is ideal for clock / data distribution applications.

Block Diagram

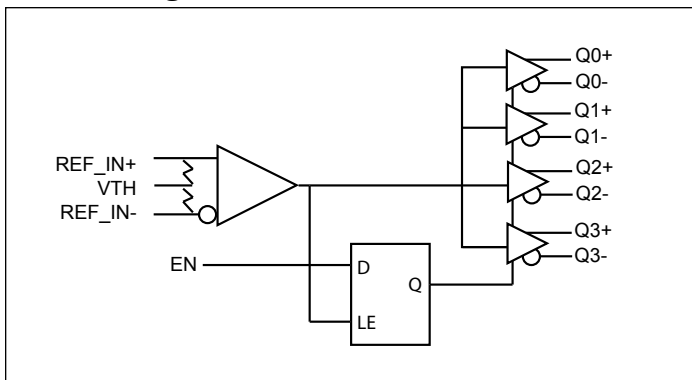

Pin Configuration

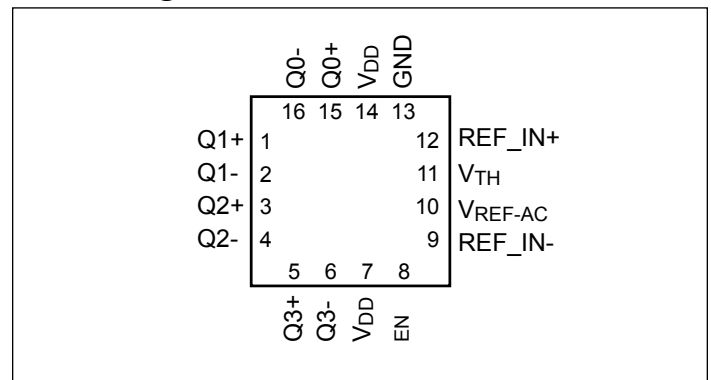

Notes:

1. No purposely added lead. Fully EU Directive 2002/95/EC (RoHS), 2011/65/EU (RoHS 2) & 2015/863/EU (RoHS 3) compliant.
2. See <https://www.diodes.com/quality/lead-free/> for more information about Diodes Incorporated’s definitions of Halogen- and Antimony-free, “Green” and Lead-free.
3. Halogen- and Antimony-free “Green” products are defined as those which contain <900ppm bromine, <900ppm chlorine (<1500ppm total Br + Cl) and <1000ppm antimony compounds.

Pin Description

Pin #	Name	Type	Description
1, 2	Q1+, Q1-	Output	Differential output pair, CML interface level.
3, 4	Q2+, Q2-	Output	Differential output pair, CML interface level.
5, 6	Q3+, Q3-	Output	Differential output pair, CML interface level.
7	V _{DD}	Power	Core Power Supply
8	EN	Input	Synchronous Output Enable, with internal 25k-ohm pull-up resistor. Logic high selects enable, and logic low selects disable.
9	REF_IN-	Input	Differential IN negative input, AC and DC coupled
10	V _{REF-AC}	Output	Reference Voltage: Biased to V _{DD} -1.4V. Used when AC coupling inputs
11	V _{TH}	Input	Differential pair IN center-tap node. Tie to V _{REF-AC} for AC coupled inputs.
12	REF_IN+	Input	Differential IN positive input, AC and DC coupled
13	GND	Power	Ground
14	V _{DD}	Power	Core Power Supply
15, 16	Q0+, Q0-	Output	Differential output pair, CML interface level.

Maximum Ratings (Over operating free-air temperature range)

Storage Temperature.....	-65°C to+155°C
Ambient Temperature with Power Applied.....	-40°C to+85°C
3.3V Core Supply Voltage	-0.5 to +4.6V
ESD Protection (HBM)	2000V

Note:

Stresses greater than those listed under MAXIMUM RATINGS may cause permanent damage to the device. This is a stress rating only and functional operation of the device at these or any other conditions above those indicated in the operational sections of this specification is not implied. Exposure to absolute maximum rating conditions for extended periods may affect reliability.

DC Characteristics

Symbol	Parameter	Conditions	Min.	Typ.	Max.	Units
V _{DD}	Core Power Supply Voltage		3.0		3.6	V
			2.375		2.625	V
T _A	Ambient Temperature		-40		85	°C
I _{DD}	Power Supply Current	No load, max V _{DD}			130	mA
R _{DIFF_IN}	Differential Input Resistance (REF_IN+ to REF_IN-)		90	100	110	Ω
V _{IH}	Input High Voltage		1.2		V _{DD} - 0.9	V
V _{IL}	Input Low Voltage		0.4		V _{IH} - 0.1	V
V _{IN}	Input Voltage Swing		0.1		1.7	V
V _{DIFF_IN}	Differential Input Swing		0.2			V
V _{REF-AC}	Output Reference Voltage		V _{DD} -1.50	V _{DD} -1.30	V _{DD} -1.15	V

LVC MOS/LVTTL DC Characteristics (T_A = -40°C to +85°C, V_{DD} = 2.5V ±5% to 3.3V ±10%)

Symbol	Parameter	Conditions	Min.	Typ.	Max.	Units
V _{IH}	Input High Voltage		2.0		V _{DD}	V
V _{IL}	Input Low Voltage		0		0.8	
I _{IH}	Input High Current		-125		20	μA
I _{IL}	Input Low Current		-300			μA

CML DC Characteristics (T_A = -40°C to +85°C, V_{DD} = 3.3V ±10%, 2.5V ±5%)

Symbol	Parameter	Conditions	Min.	Typ.	Max.	Units
V _{OUT}	Output Voltage Swing	Single Ended	325	400		mV

AC Characteristics ($T_A = -40^{\circ}\text{C}$ to $+85^{\circ}\text{C}$, $V_{DD} = 3.3\text{V} \pm 10\%$, $2.5\text{V} \pm 5\%$)

Symbol	Parameter	Conditions	Min	Typ	Max	Units
f_{max}	Output Frequency			6		GHz
t_{pd}	Propagation Delay ⁽¹⁾				400	ps
T_{sk}	Output-to-output Skew ⁽²⁾				20	ps
	Device to Device skew				200	ps
T_s	Setup time			240		ps
T_h	Hold time			240		ps
V_{PP}	Differential peak to peak voltage	$f \leq 3 \text{ GHz}$	600	800	850	mV
t_r/t_f	Output Rise/Fall time	20% - 80%, $f \leq 4 \text{ GHz}$	40		90	ps
t_{odc}	Output duty cycle	$f \leq 1 \text{ GHz}$	48		52	%
		$1 \text{ GHz} \leq f < 6 \text{ GHz}$	40		60	%
t_j	Buffer additive jitter RMS	156.25MHz with 12KHz to 20MHz integration range (CML)		40		fs

Notes:

1. Measured from the differential input to the differential output crossing point
2. Defined as skew between outputs at the same supply voltage and with equal loads. Measured at the output differential crossing point

Output Swing vs Frequency

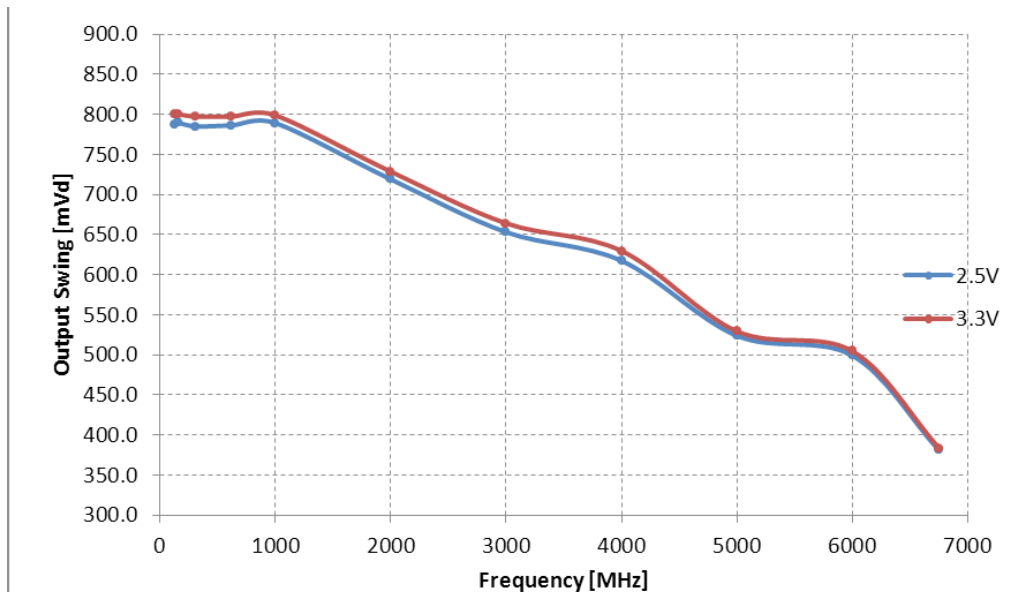

Typical Output Eye Diagrams

3.15Gb/s XAUI CML output waveform

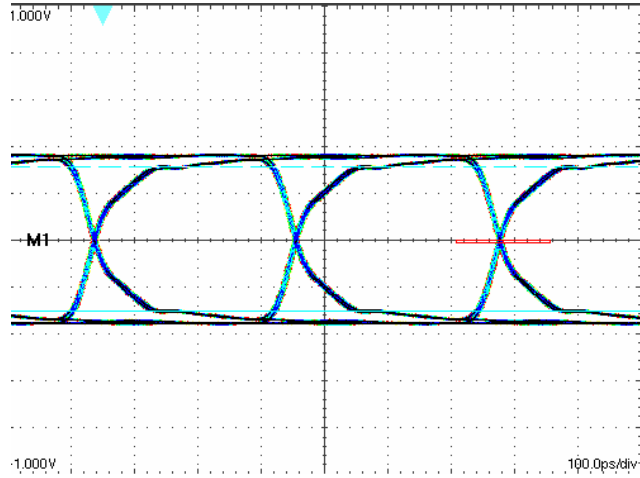

6Gb/s SATA CML output waveform

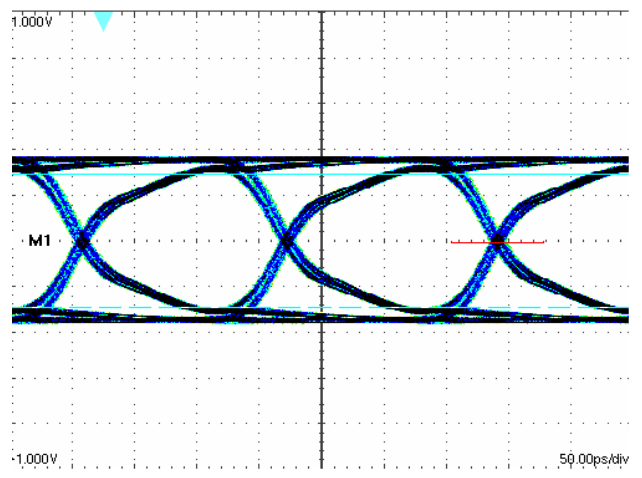

10.5Gb/s Fiber Channel CML output waveform

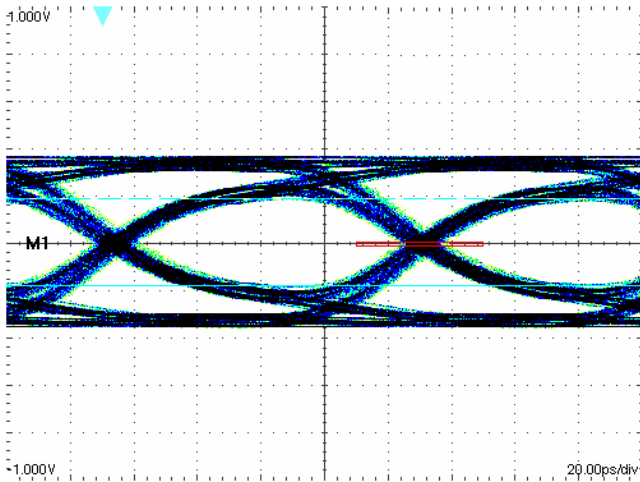

12Gb/s SATA CML output waveform

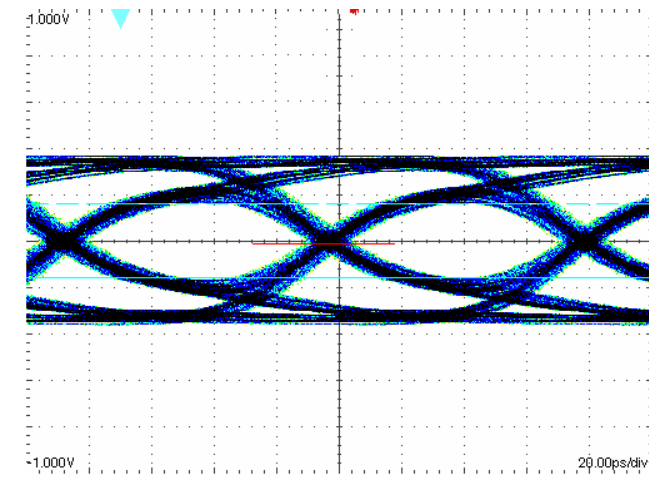

PI6C5946004

Configuration Test Load Board Termination for CML Outputs

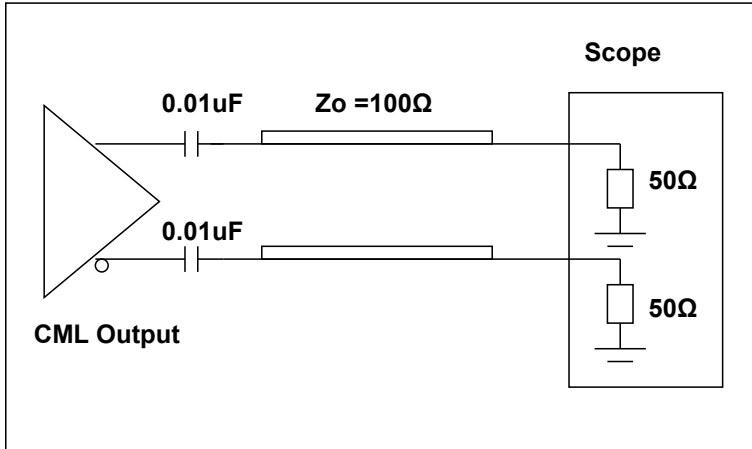

Thermal Information

Symbol	Description	Condition	
Θ_{JA}	Junction-to-ambient thermal resistance	Still air	54.4 °C/W
Θ_{JC}	Junction-to-case thermal resistance		40.8 °C/W

Application Information

Suggest for Unused Inputs and Outputs

LVC MOS Input Control Pins

It is suggested to add pull-up=4.7k and pull-down=1k for LVC MOS pins even though they have internal pull-up/down but with much higher value (>=50k) for higher design reliability.

REF_IN= / REF_IN- Input Pins

They can be left floating if unused. For added reliability, connect 1kΩ to GND.

Outputs

All unused outputs are suggested to be left open and not connected to any trace. This can lower the IC power supply power.

Power Decoupling & Routing

VDD Pin Decoupling

As general design rule, each VDD pin must have a 0.1uF decoupling capacitor. For better decoupling, 1uF can be used. Locating the decoupling capacitor on the component side has better decoupling filter result as shown in Fig. 1.

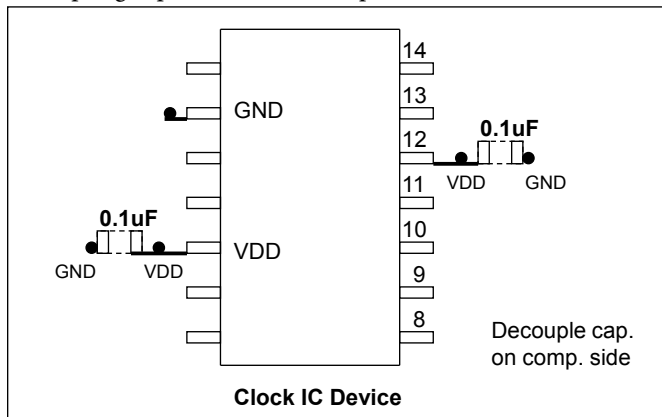

Fig 1: Placement of Decoupling caps

Differential Clock Trace Routing

Always route differential signals symmetrically, make sure there is enough keep-out space to the adjacent trace (>20mil.). In 156.25MHz XO drives IC example, it is better routing differential trace on component side as the following Fig. 2.

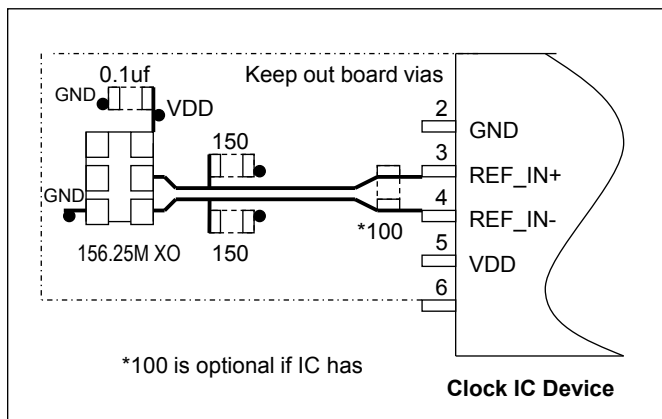

Fig 2: IC routing for XO drive

Clock timing is the most important component in PCB design, so its trace routing must be planned and routed as a first priority in manual routing. Some good practices are to use minimum vias (total trace vias count <4), use independent layers with good reference plane and keep other signal traces away from clock traces (>20mil.) etc.

CML and LVDS Input Interface

LVPECL and LVDS DC Input

LVPECL and LVDS clock input to this IC is connected as shown in the Fig. 3.

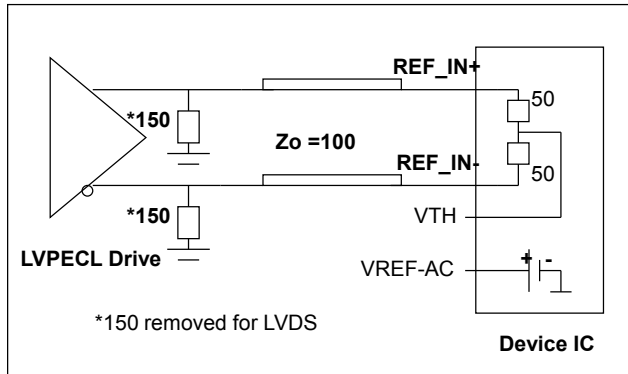

Fig 3: CML/ LVDS Input

LVPECL and LVDS AC Input

LVPECL and LVDS AC drive to this clock IC requires the use of the VREF-AC output to recover the DC bias for the IC input as shown in Fig. 4

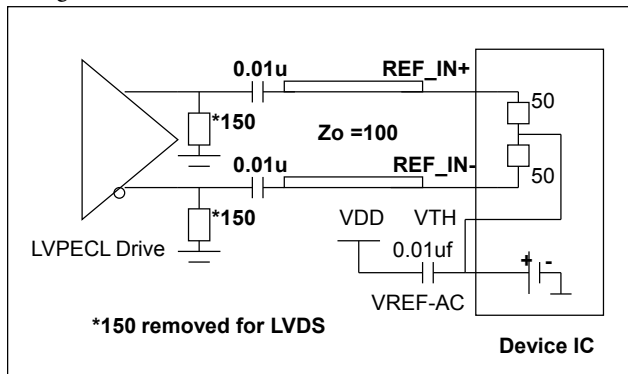

Fig 4: CML/ LVDS AC Coupled Input

CML AC-Coupled Input

CML AC-coupled drive requires a connection to VREF-AC as shown in Fig. 5. The CML DC drive is not recommended as different vendors have different CML DC voltage level. CML is mostly used in AC coupled drive configuration for data and clock signals.

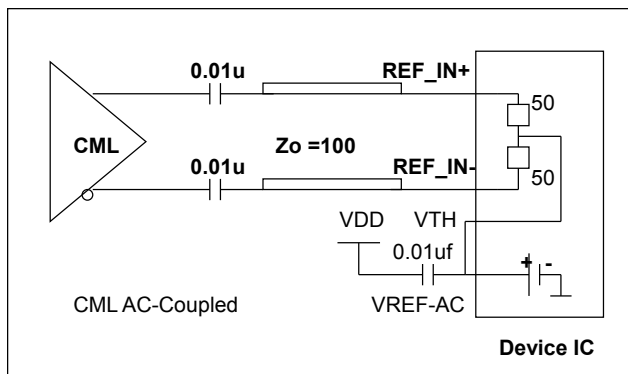

Fig 5: CML AC-Coupled Input Interface

HCSL AC-Coupled Input

It is suggested to use AC coupling to buffer PCIe HCSL 100MHz clock since its V_{cm} is relatively low at about 0.4V, as shown in Fig. 6.

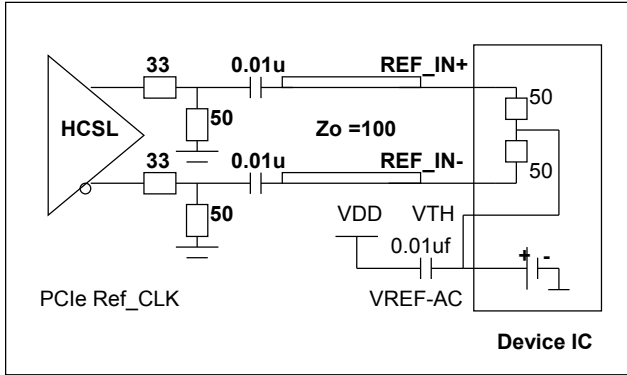

Fig 6: HCSL AC-Coupled Input Interface

CMOS Clock DC Drive Input

LVC MOS clock has voltage V_{oh} levels such as 3.3V, 2.5V, 1.8V. CMOS drive requires a V_{cm} design at the input: $V_{cm} = \frac{1}{2} (CMOS V)$ as shown in Fig. 7. $R_s = 22 \sim 33\Omega$ typically.

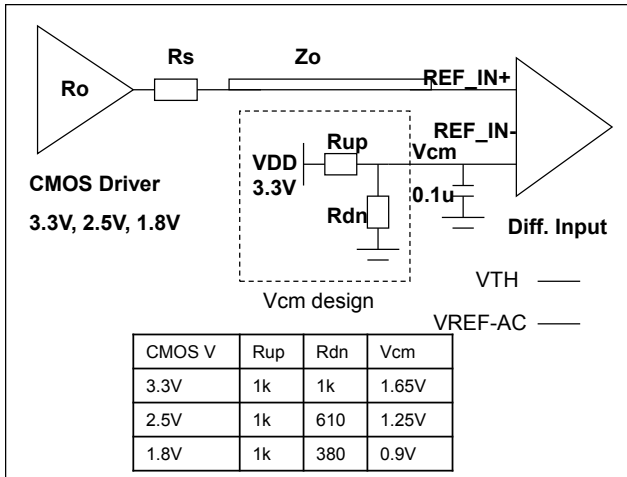

Fig 7: CMOS DC Input V_{cm} Design

Device LVPECL Output Terminations

LVPECL Output Popular Termination

The most popular LVPECL termination is 150ohm pull-down bias and 100ohm across at RX side. Please consult ASIC datasheet if it already has 100ohm or equivalent internal termination. If so, do not connect external 100ohm across as shown in Fig. 8. This popular termination's advantage is that it does not allow any bias through from V_{DD} . This prevents V_{DD} system noise coupling onto clock trace.

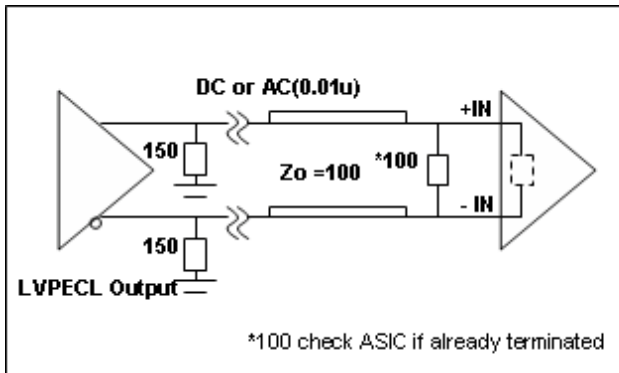

Fig. 8 LVPECL Output Popular Termination

LVPECL Output Thevenin Termination

Fig. 9 shows CML output Thevenin termination which is used for shorter trace drive (<5in.), but it takes V_{DD} bias current and V_{DD} noise can get onto clock trace. It also requires more component count. So it is seldom used today.

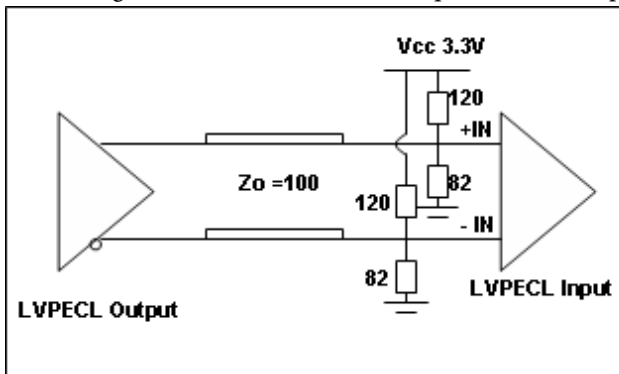

Fig. 9 LVPECL Thevenin Output Termination

CML Output AC Thevenin Termination

CML AC Thevenin terminations require a 150ohm pull-down before the AC coupling capacitor at the source as shown in Fig. 10. Note that pull-up/down resistor value is swapped compared to Fig. 9. This circuit is good for short trace (<5in.) application only.

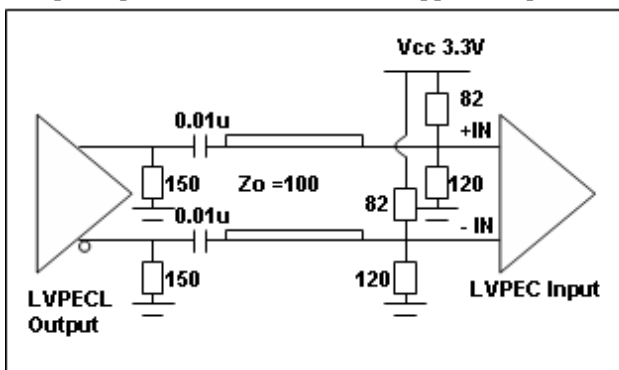

Fig. 10 CML Output AC Thevenin Termination

CML Output Drive HCSL Input

Using the CML output to drive a HCSL input can be done using a typical CML AC Thenvenin termination scheme. Use pull-up/down 450/60ohm to generate $V_{cm}=0.4V$ for the HCSL input clock. This termination is equivalent to 50Ohm load as shown in Fig. 11.

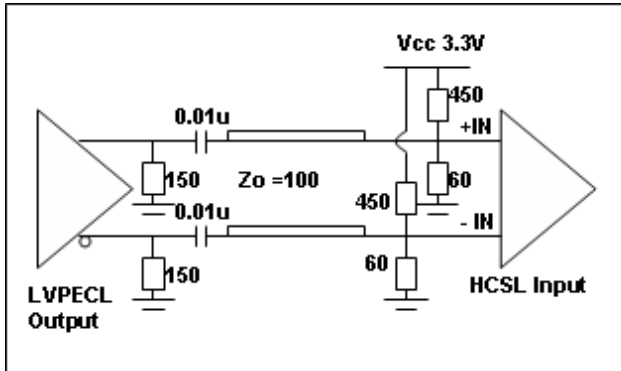

Fig. 11 CML Output Drive HCSL Termination

LVPECL Output V_{swing} Adjustment

It is suggested to add another cross 100ohm at TX side to tune the LVPECL output V_{swing} without changing the optimal 150ohm pull-down bias in Fig. 12. This form of double termination can reduce the V_{swing} in $\frac{1}{2}$ of the original at the RX side. By fine tuning the 100ohm resistor at the TX side with larger values like 150 to 200ohm, one can increase the V_{swing} by $> \frac{1}{2}$ ratio.

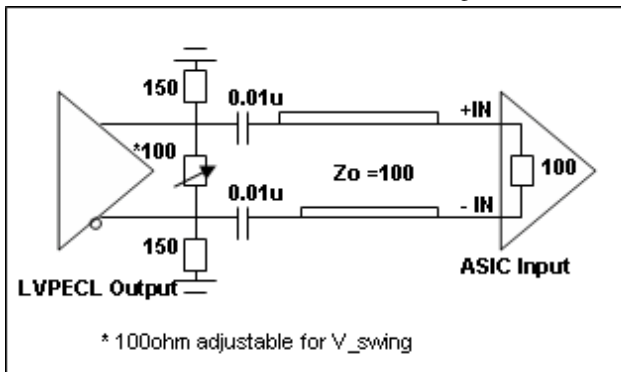
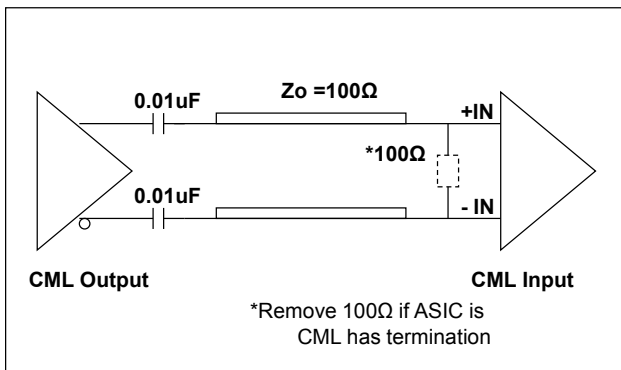

Fig. 12 LVPECL Output V_{swing} Adjustment

CML AC Output Drive

CML is implemented mostly via AC coupling. With AC coupling, CML can drive CML and LVDS inputs as well with an external 100 ohm equivalent differential termination.



Clock Jitter Definitions

Total jitter= RJ + DJ

Random Jitter (RJ) is unpredictable and unbounded timing noise that can fit in a Gaussian math distribution in RMS. RJ test values are directly related with how long or how many test samples are available. Deterministic Jitter (DJ) is timing jitter that is predictable and periodic in fixed interference frequency. Total Jitter (TJ) is the combination of random jitter and deterministic jitter: $TJ = \sqrt{RJ^2 + DJ^2}$, where K is a factor based on total test sample count. JEDEC std. specifies digital clock TJ in 10k random samples.

Phase Jitter

Phase noise is short-term random noise attached on the clock carrier and it is a function of the clock offset from the carrier, for example dBc/Hz@10kHz which is phase noise power in 1-Hz normalized bandwidth vs. the carrier power @10kHz offset. Integration of phase noise in plot over a given frequency band yields RMS phase jitter, for example, to specify phase jitter ≤ 1 ps at 12k to 20MHz offset band as SONET standard specification.

PCIe Ref_CLK Jitter

PCIe reference clock jitter specification requires testing via the PCI-SIG jitter tool, which is regulated by US PCI-SIG organization. The jitter tool has PCIe Serdes embedded filter to calculate the equivalent jitter that relates to data link eye closure. Direct peak-peak jitter or phase jitter test data, normally is higher than jitter measure using PCI-SIG jitter tool. It has high-frequency jitter and low-frequency jitter spec. limit. For more information, please refer to the PCI-SIG website: <http://www.pcisig.com/specifications/pciexpress/>

Device Thermal Calculation

Fig. 13 shows the JEDEC thermal model in a 4-layer PCB.

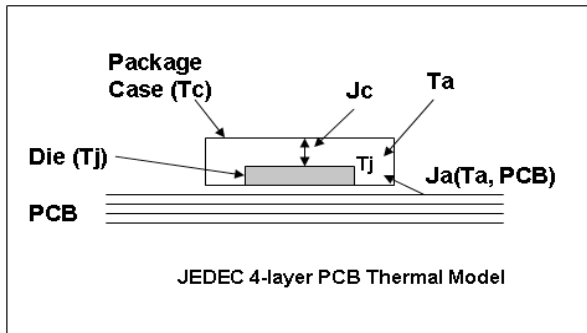

Fig. 13 JEDEC IC Thermal Model

Important factors to influence device operating temperature are:

- 1) The power dissipation from the chip (P_{chip}) is after subtracting power dissipation from external loads. Generally it can be the no-load device I_{dd} .
- 2) Package type and PCB stack-up structure, for example, 1oz 4 layer board. PCB with more layers and are thicker has better heat dissipation.
- 3) Chassis air flow and cooling mechanism. More air flow M/s and adding heat sink on device can reduce device final die junction temperature T_j .

The individual device thermal calculation formula:

$$T_j = T_a + P_{chip} \times J_a$$

$$T_c = T_j - P_{chip} \times J_c$$

J_a ___ Package thermal resistance from die to the ambient air in C/W unit; This data is provided in JEDEC model simulation. An air flow of 1m/s will reduce J_a (still air) by 20~30%

J_c ___ Package thermal resistance from die to the package case in C/W unit

T_j ___ Die junction temperature in C (industry limit <125C max.)

T_a ___ Ambient air temperature in C

T_c ___ Package case temperature in C

P_{chip} ___ IC actually consumes power through I_{ee} /GND current

Thermal calculation example

To calculate T_j and T_c of PI6CV304 in an SOIC-8 package:

Step 1: Go to Pericom web to find $J_a=157$ C/W, $J_c=42$ C/W

<http://www.pericom.com/support/packaging/packaging-mechanicals-and-thermal-characteristics/>

Step 2: Go to device datasheet to find $I_{dd}=40$ mA max.

I_{DD}	Supply Current	$C_L = 33pF/33MHz$	20	mA
		$C_L = 33pF/66MHz$	40	
		$C_L = 22pF/80MHz$	35	
		$C_L = 15pF/100MHz$	32	
		$C_L = 10pF/125MHz$	28	
		$C_L = 10pF/155MHz$	41	

Step 3: $P_{total} = 3.3V \times 40mA = 0.132W$

Step 4: If $T_a=85C$

$$T_j = 85 + J_a \times P_{total} = 85 + 25.9 = 105.7C$$

$$T_c = T_j + J_c \times P_{total} = 105.7 - 5.54 = 100.1C$$

Note:

The above calculation is directly using I_{dd} current without subtracting the load power, so it is a conservative estimation. For more precise thermal calculation, use P_{unload} or P_{chip} from device I_{ee} or GND current to calculate T_j , especially for CML buffer ICs that have a 150ohm pull-down and equivalent 100ohm differential RX load.

Part Marking

ZH Package



YY: Year

WW: Workweek

1st X: Assembly Code

2nd X: Fab Code

Packaging Mechanical: 16-TQFN (ZH)

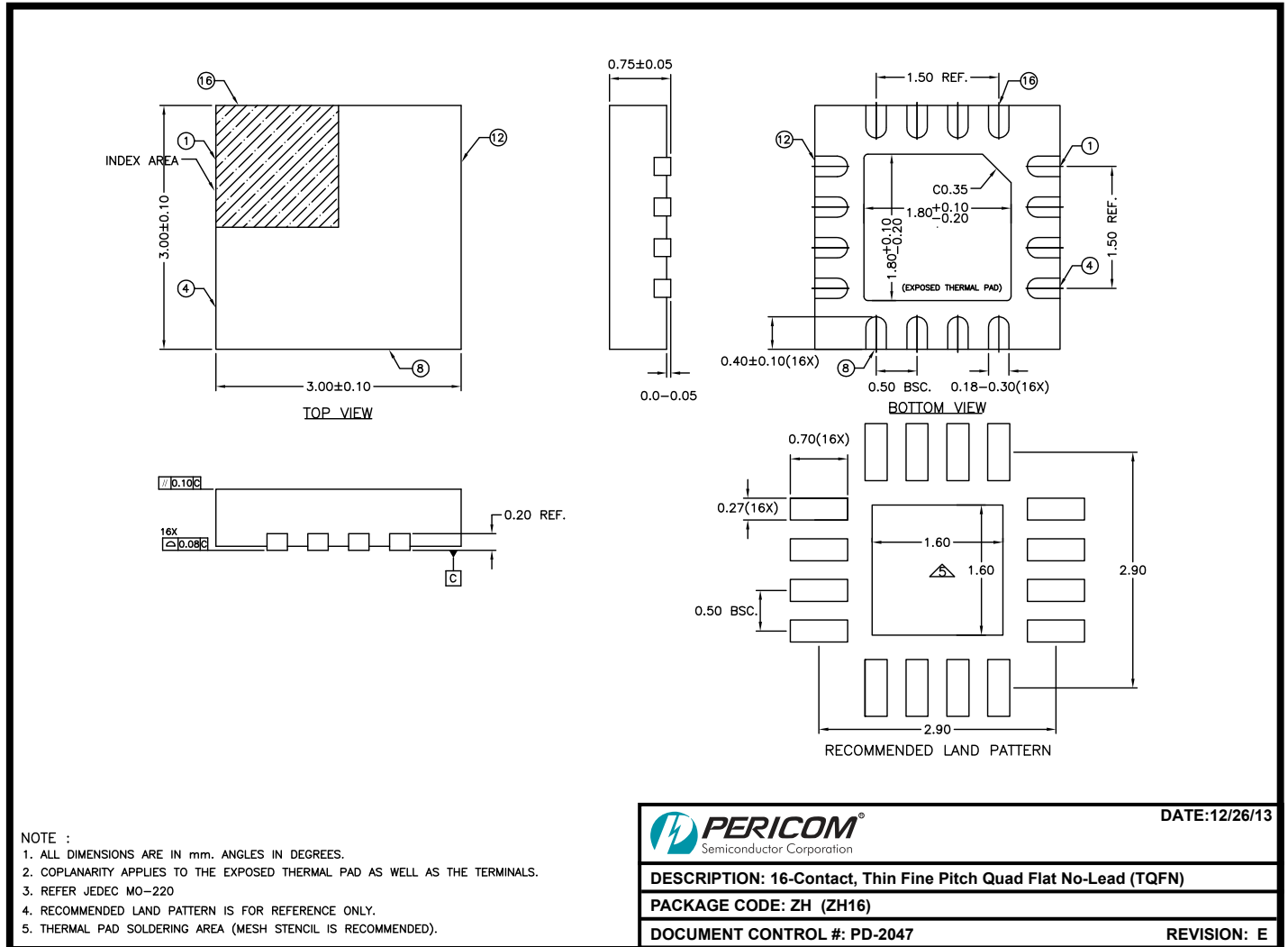

14-0244

For latest package info.

please check: <http://www.diodes.com/design/support/packaging/pericom-packaging/packaging-mechanicals-and-thermal-characteristics/>

Ordering Information

Ordering Code	Package Code	Package Description
PI6C5946004ZHIEX	ZH	16-contact, Thin Fine Pitch Quad Flat No-Lead (TQFN)

Notes:

1. No purposely added lead. Fully EU Directive 2002/95/EC (RoHS), 2011/65/EU (RoHS 2) & 2015/863/EU (RoHS 3) compliant.
2. See <https://www.diodes.com/quality/lead-free/> for more information about Diodes Incorporated's definitions of Halogen- and Antimony-free, "Green" and Lead-free.
3. Halogen- and Antimony-free "Green" products are defined as those which contain <900ppm bromine, <900ppm chlorine (<1500ppm total Br + Cl) and <1000ppm antimony compounds.
4. E = Pb-free and Green
5. X suffix = Tape/Reel

IMPORTANT NOTICE

DIODES INCORPORATED MAKES NO WARRANTY OF ANY KIND, EXPRESS OR IMPLIED, WITH REGARDS TO THIS DOCUMENT, INCLUDING, BUT NOT LIMITED TO, THE IMPLIED WARRANTIES OF MERCHANTABILITY AND FITNESS FOR A PARTICULAR PURPOSE (AND THEIR EQUIVALENTS UNDER THE LAWS OF ANY JURISDICTION).

Diodes Incorporated and its subsidiaries reserve the right to make modifications, enhancements, improvements, corrections or other changes without further notice to this document and any product described herein. Diodes Incorporated does not assume any liability arising out of the application or use of this document or any product described herein; neither does Diodes Incorporated convey any license under its patent or trademark rights, nor the rights of others. Any Customer or user of this document or products described herein in such applications shall assume all risks of such use and will agree to hold Diodes Incorporated and all the companies whose products are represented on Diodes Incorporated website, harmless against all damages.

Diodes Incorporated does not warrant or accept any liability whatsoever in respect of any products purchased through unauthorized sales channel.

Should Customers purchase or use Diodes Incorporated products for any unintended or unauthorized application, Customers shall indemnify and hold Diodes Incorporated and its representatives harmless against all claims, damages, expenses, and attorney fees arising out of, directly or indirectly, any claim of personal injury or death associated with such unintended or unauthorized application.

Products described herein may be covered by one or more United States, international or foreign patents pending. Product names and markings noted herein may also be covered by one or more United States, international or foreign trademarks.

This document is written in English but may be translated into multiple languages for reference. Only the English version of this document is the final and definitive format released by Diodes Incorporated.

LIFE SUPPORT

Diodes Incorporated products are specifically not authorized for use as critical components in life support devices or systems without the express written approval of the Chief Executive Officer of Diodes Incorporated. As used herein:

A. Life support devices or systems are devices or systems which:

1. are intended to implant into the body, or

2. support or sustain life and whose failure to perform when properly used in accordance with instructions for use provided in the labeling can be reasonably expected to result in significant injury to the user.

B. A critical component is any component in a life support device or system whose failure to perform can be reasonably expected to cause the failure of the life support device or to affect its safety or effectiveness.

Customers represent that they have all necessary expertise in the safety and regulatory ramifications of their life support devices or systems, and acknowledge and agree that they are solely responsible for all legal, regulatory and safety-related requirements concerning their products and any use of Diodes Incorporated products in such safety-critical, life support devices or systems, notwithstanding any devices- or systems-related information or support that may be provided by Diodes Incorporated. Further, Customers must fully indemnify Diodes Incorporated and its representatives against any damages arising out of the use of Diodes Incorporated products in such safety-critical, life support devices or systems.

Copyright © 2016, Diodes Incorporated

www.diodes.com