

QUICK START GUIDE FOR DEMONSTRATION CIRCUIT 1381A LOW QUIESCENT CURRENT, DUAL OUTPUT SYNCHRONOUS BUCK CONVERTER

LTC3857EUH/LTC3858EUH

DESCRIPTION

Demonstration circuit 1381A is a Low Quiescent Current, Dual Output Synchronous Buck Converter featuring the LTC3857EUH/LTC3858EUH. The circuit is single sided layout, while the package style for the LTC3857/8EUH is a 32 lead (5mm x 5mm) QFN package

The main features of the board include rail tracking (LTC3857EUH only), an internal 5V linear regulator for bias, RUN pins for each output, a PGOOD signal (CH1 only) and a Mode selector that allow the converter to run in CCM, pulse skip or Burst Mode operation. Synchronization to an external clock is also possible.

Two versions of the board are available. DC-1381A-A is for the LTC3857EUH, while the DC1381A-B is for the LTC3858EUH. The

LTC3857EUH offers lower quiescent current and smaller burst mode ripple, while the LTC3858EUH offers latch-off protection and increased burst mode efficiency.

The wide input voltage range of 4.5V to 36V is suitable for automotive or other battery fed application where low quiescent current is important. The LTC3857EUH and LTC3858EUH datasheets give a complete description of these parts, operation and application information. The datasheets must be read in conjunction with this quick start guide for demo circuit 1381A.

Design files for this circuit board are available. Call the LTC factory.

Burst Mode is a trademark of Linear Technology Corporation

Table 1. Performance Summary ($T_A = 25^\circ\text{C}$)

PARAMETER	CONDITION	VALUE	
Minimum Input Voltage		4.5V [#]	
Maximum Input Voltage		36V	
Output Voltage V_{OUT1}	$V_{IN} = 4.5\text{V to }36\text{V}, I_{OUT1} = 0\text{A to }5\text{A}$	3.3V $\pm 2\%$	
Output Voltage V_{OUT2}	$V_{IN} = 9\text{V to }36\text{V}, I_{OUT2} = 0\text{A to }3\text{A}$	8.5V $\pm 2\%$	
Nominal Switching Frequency		350kHz	
Efficiency, DC1381A-A/B See Figures 3 to 6 for efficiency curves		$V_{IN} = 24\text{V}$	$V_{IN} = 36\text{V}$
	$V_{OUT1} = 3.3\text{V}, I_{OUT1} = 5\text{A}$	92.5%* Typical	90.4%* Typical
	$V_{OUT2} = 8.5\text{V}, I_{OUT1} = 3\text{A}$	96.6%* Typical	95.4%* Typical
* Measured at bulk output capacitor	# Minimum input voltage required for 8.5Vout regulation is 9Vin		

QUICK START PROCEDURE

Demonstration circuit 1381A is easy to set up to evaluate the performance of the LTC3857EUH/LTC3858EUH. Refer to Figure 1 for proper measurement equipment setup and follow the procedure below:

NOTE: When measuring the input or output voltage ripple, care must be taken to avoid a long ground

lead on the oscilloscope probe. Measure the input or output voltage ripple by probing directly across the bulk V_{in} or V_{out} capacitor. See Figure 2 for proper scope probe technique.

1. Place jumpers in the following positions:

QUICK START GUIDE FOR DEMONSTRATION CIRCUIT 1381A

LOW QUIESCENT CURRENT, DUAL OUTPUT SYNCHRONOUS BUCK CONVERTER

- JP2** Burst Mode
- JP3** On
- JP4** On
- JP5** SS
- JP6** SS

2. With power off, connect the input power supply to Vin and GND.
3. Turn on the power at the input.

NOTE: Make sure that the input voltage does not exceed 26V.

4. Check for the proper output voltages.
 $V_{out1} = 3.234V$ to $3.366V$,
 $V_{out2} = 8.330V$ to $8.670V$

NOTE: If there is no output, temporarily disconnect the load to make sure that the load is not set too high.

5. Once the proper output voltages are established, adjust the loads within the operating range and observe the output voltage regulation, ripple voltage, efficiency and other parameters.
6. Different operating modes can be evaluated by changing position of jumper JP3.

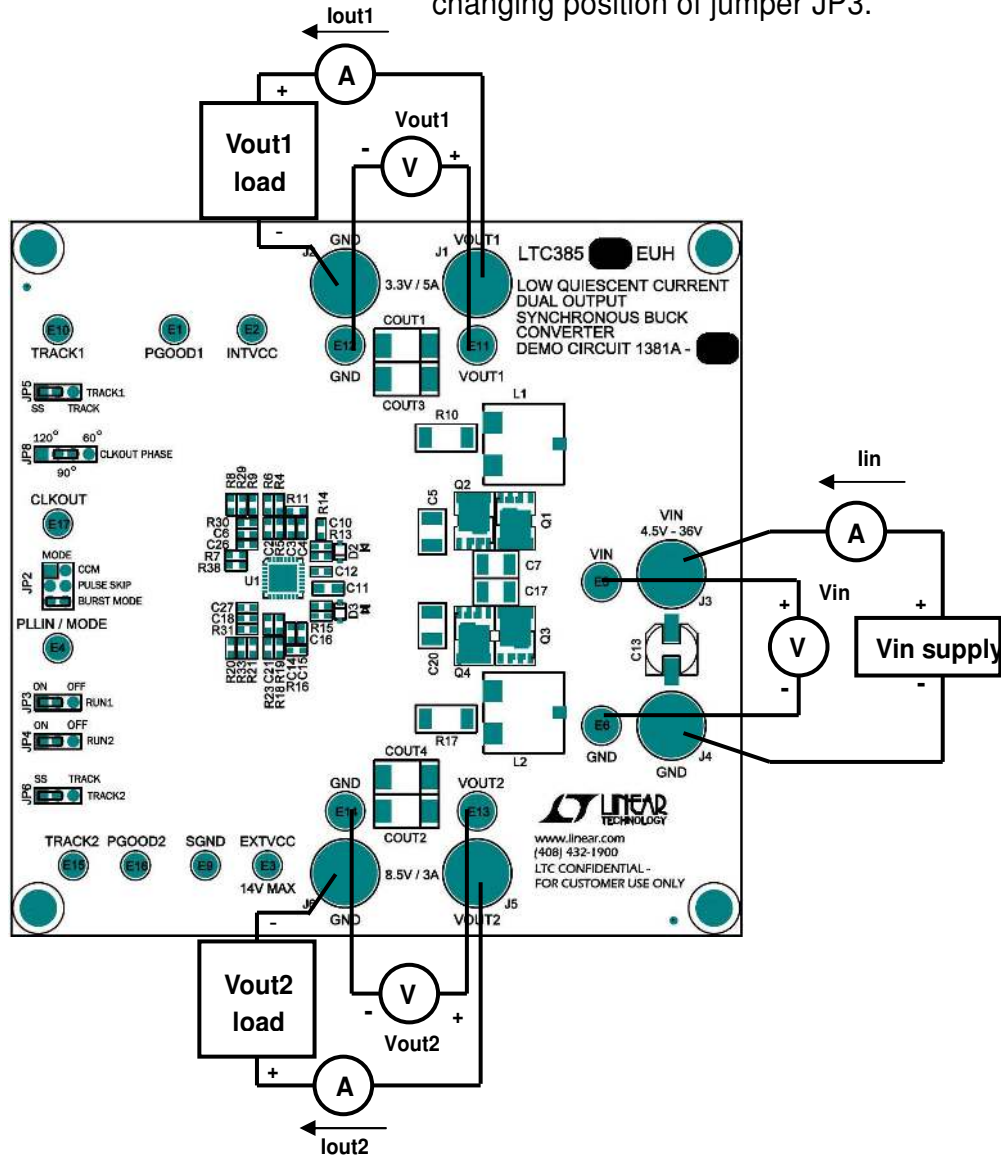

Figure 1. Proper Measurement Equipment Setup

QUICK START GUIDE FOR DEMONSTRATION CIRCUIT 1381A LOW QUIESCENT CURRENT, DUAL OUTPUT SYNCHRONOUS BUCK CONVERTER

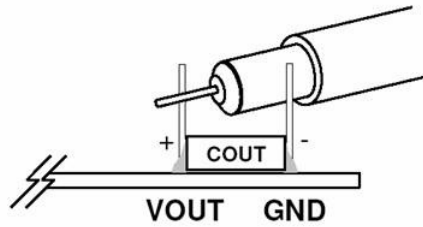

Figure 2. Measuring Input or Output Ripple Directly Across Bulk Capacitor

RAIL TRACKING

Demonstration circuit 1381 is setup for independent soft start without tracking. The soft start ramp-rate is determined by the value of the SS capacitors C1 and C23. This board can also be operated in coincident tracking mode with either

output as master or both can slave an external ramp Refer to Table 2 for tracking options and to the data sheet for more details.

Table 2. Output Tracking Options

CONFIGURATION	TRACK/SS JUMPERS		TERMINALS	
	JP3	JP4	TRACK1	TRACK2
Soft Start Without Tracking				
Vout1	SS		No connection / Don't care	
Vout2		SS		No connection / Don't care
Coincident Tracking:				
Vout1 tracking External Ramp	TRACK		Connect external ramp	
Vout2 tracking External Ramp		TRACK		Connect external ramp
Vout2 tracking Vout1	SS	TRACK	No connection / Don't care	Connect to Vout1
Vout1 tracking Vout2	TRACK	SS	Connect to Vout2	No connection / Don't care

INDUCTOR DCR SENSING AND RESISTOR SENSING

The DCR sense circuit uses the resistive voltage drop across the inductor to estimate the current. In contrast to the traditional sense resistor current feedback, the DCR sensing circuit offers lower cost and higher efficiency, but results in less accurate current limit due to the large variation of the inductor DC resistance. Furthermore, this indirect current sensing method cannot detect inductor saturation and requires the use of ‘soft’ saturating inductors (such as powder iron)

resulting in increased core losses or ‘hard’ saturating inductors (such as ferrite) with sufficiency high current ratings resulting in increased inductor size.

For modifying the demo board for DCR sensing, please refer to Table 3. A full load efficiency improvement of between 0.25% – 0.75% is still possible with optional DCR sensing, but since the inductors are ferrite based, short circuit performance may be compromised.

Table 3. DCR sensing component selection

	REMOVE RSENSE NETWORK	DCR NETWORK			
Vout1	R8, R9 = Open, R10 = Short	R28 = 1.37k Ω	R30 = 2.74k Ω	R29 = 0 Ω	C6 = 0.47 μ F
Vout2	R20, R21 = Open, R17 = Short	R32 = 1.91k Ω	R31 = 1.54k Ω	R33 = 0 Ω	C18 = 0.47 μ F

FREQUENCY SYNCHRONIZATION

Demonstration circuit 1381’s Mode selector allows the converter to run in CCM, pulse skip or Burst Mode operation by changing position of jumper JP2. For synchronizing to an external

clock source, remove jumper JP2 entirely and apply the external clock signal to the PLLIN/MODE pin. Please refer to datasheet for details on external clock signal requirements.

QUICK START GUIDE FOR DEMONSTRATION CIRCUIT 1381A LOW QUIESCENT CURRENT, DUAL OUTPUT SYNCHRONOUS BUCK CONVERTER

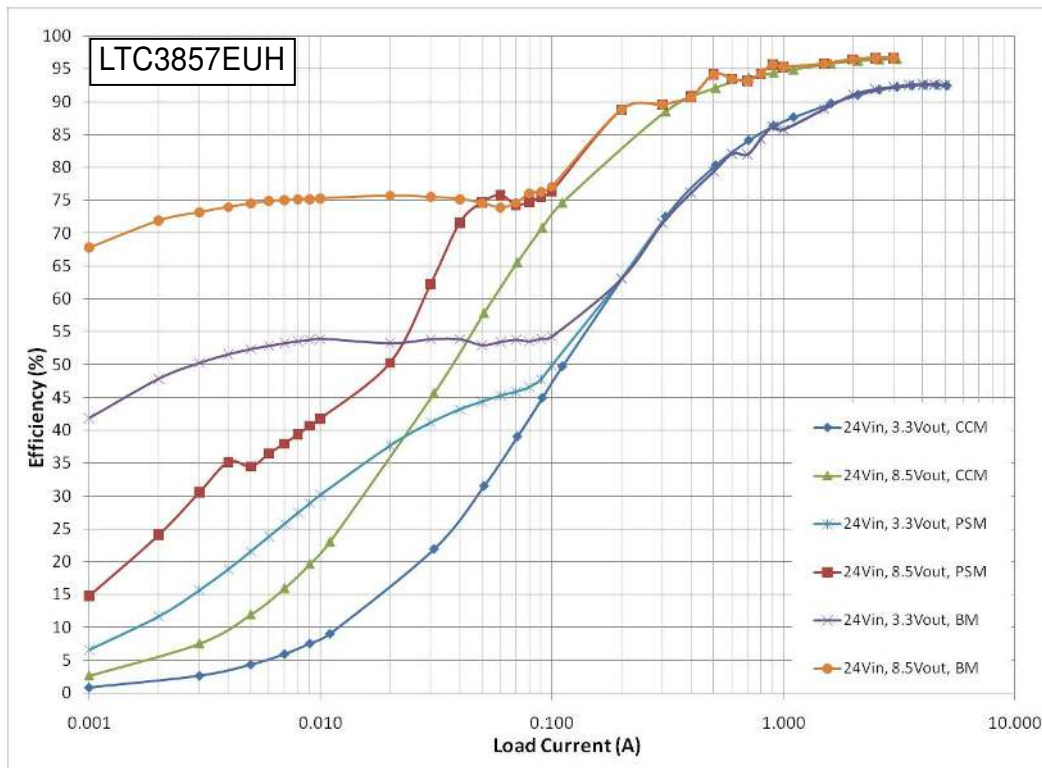

Figure 3. Typical Efficiency vs. Load Current for A-A board – 24Vin, 3.3Vout and 8.5Vout

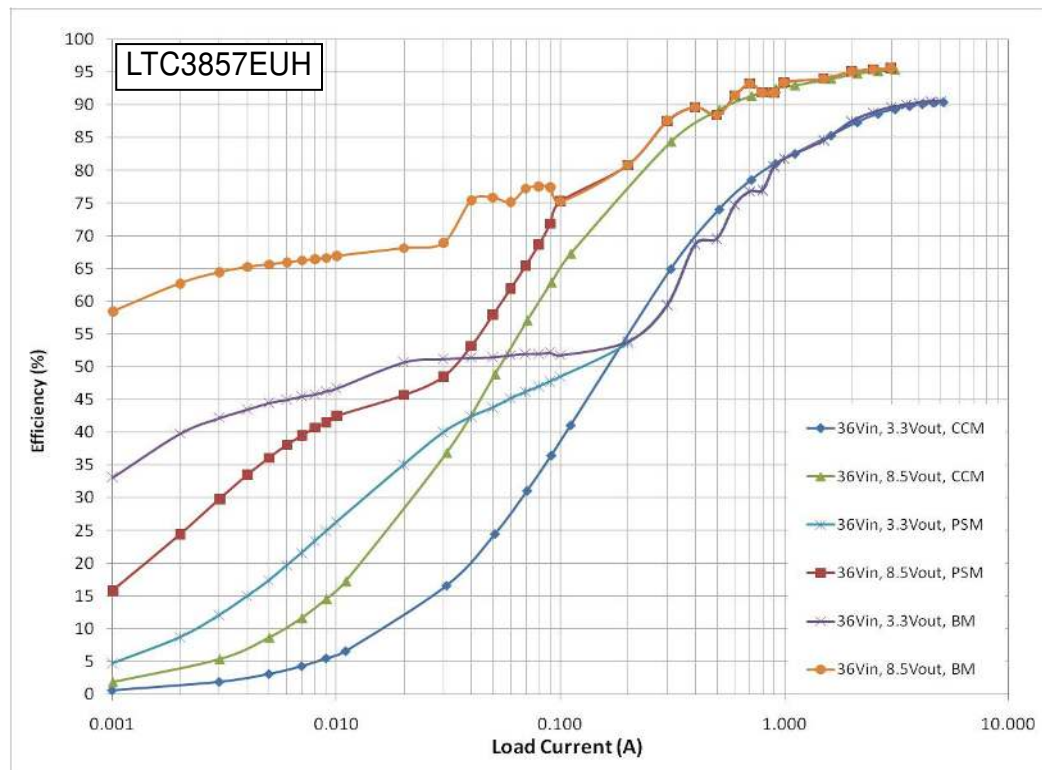

Figure 4. Typical Efficiency vs. Load Current for A-A board – 36Vin, 3.3Vout and 8.5Vout

QUICK START GUIDE FOR DEMONSTRATION CIRCUIT 1381A

LOW QUIESCENT CURRENT, DUAL OUTPUT SYNCHRONOUS BUCK CONVERTER

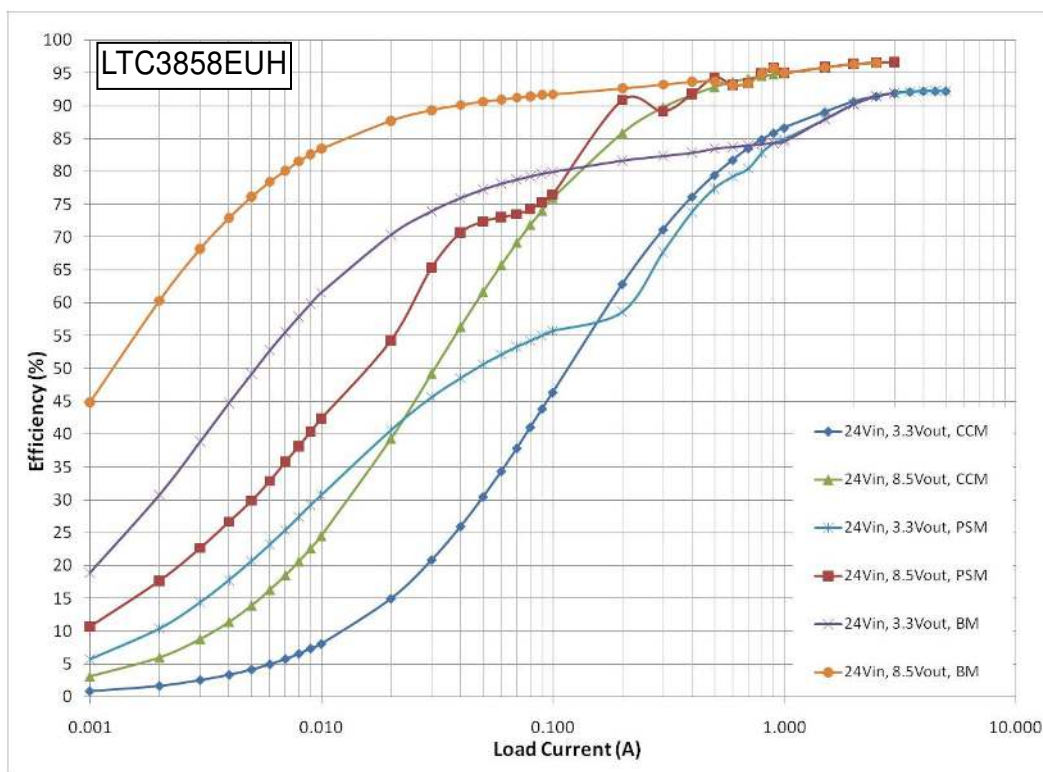

Figure 5. Typical Efficiency vs. Load Current for A-B board – 24Vin, 3.3Vout and 8.5Vout

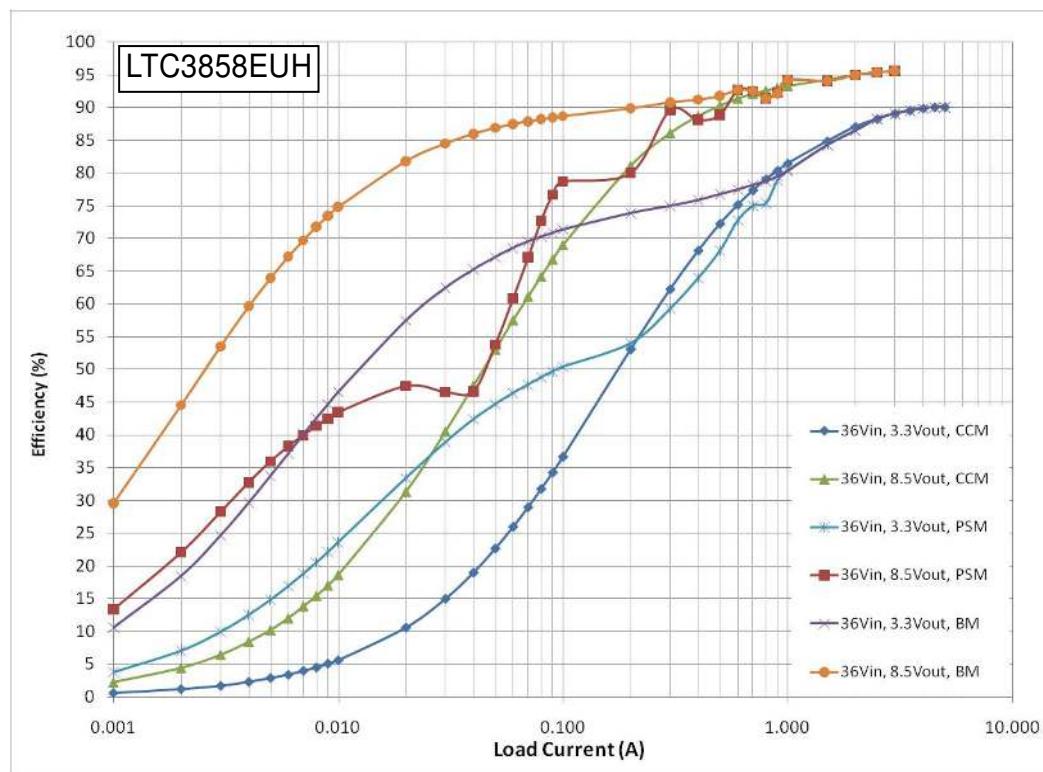
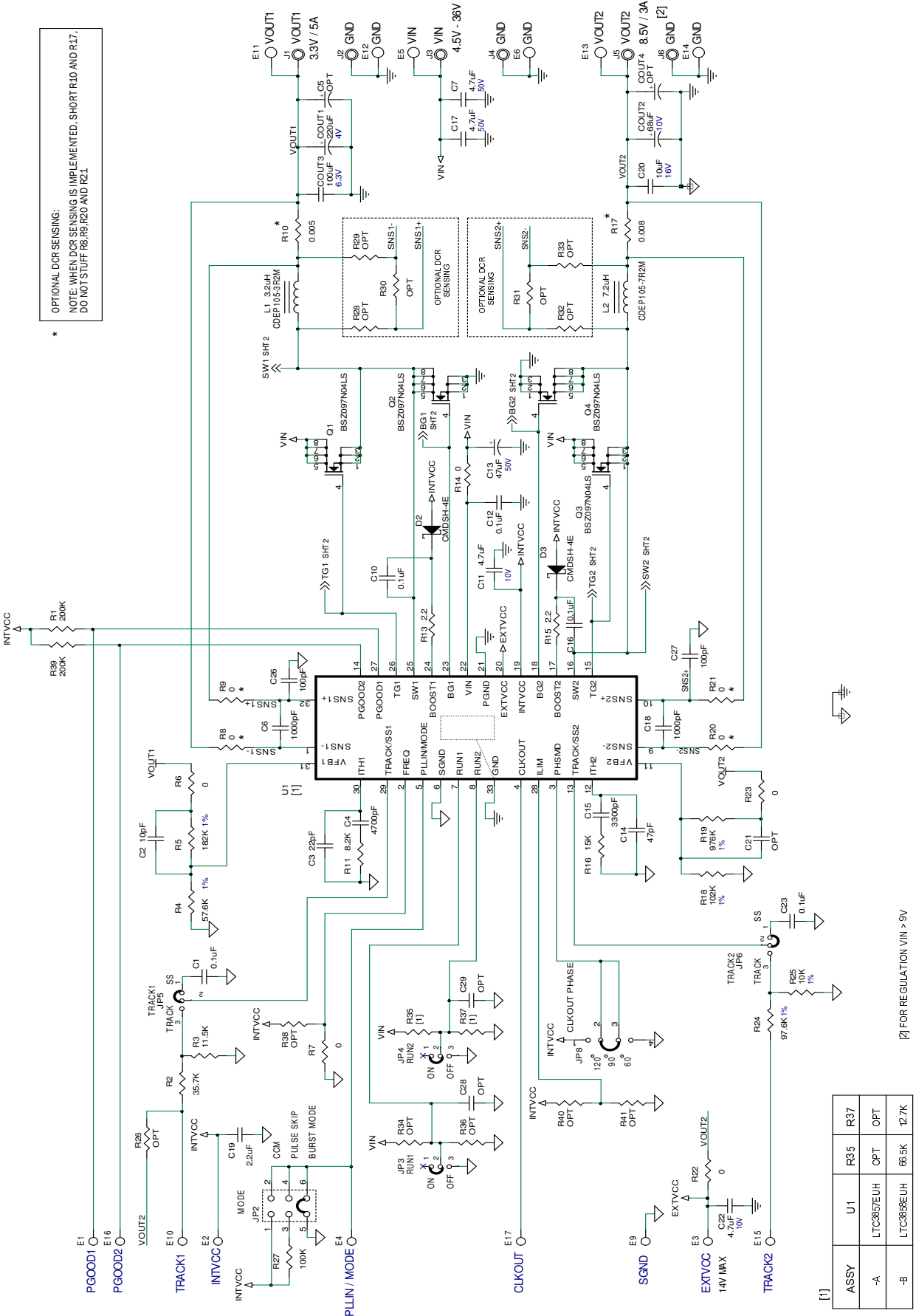

Figure 6. Typical Efficiency vs. Load Current for A-B board – 36Vin, 3.3Vout and 8.5Vout

QUICK START GUIDE FOR DEMONSTRATION CIRCUIT 1381A

LOW QUIESCENT CURRENT, DUAL OUTPUT SYNCHRONOUS BUCK CONVERTER



ASSY	U1	R35	R37
-A	LTC3885EUH	OPT	OPT
-B	LTC3885EUH	68.5K	42.7K