

1 2 3 4 5 6 7 8

F

F

E

E

D

D

C

C

B

B

A

A

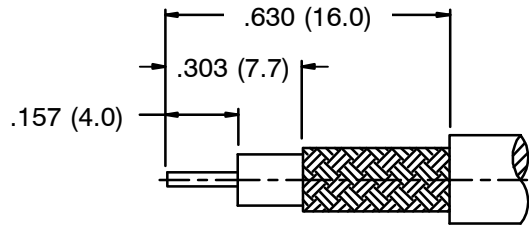

Recommended Cable Stripping Dim's

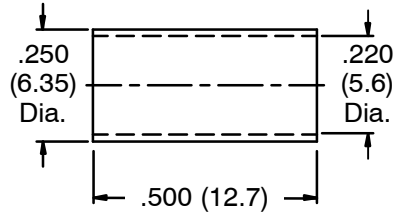
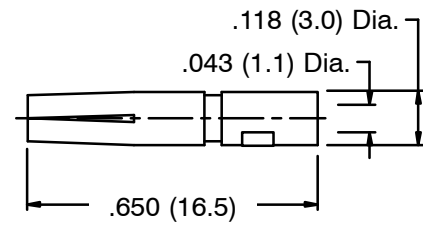
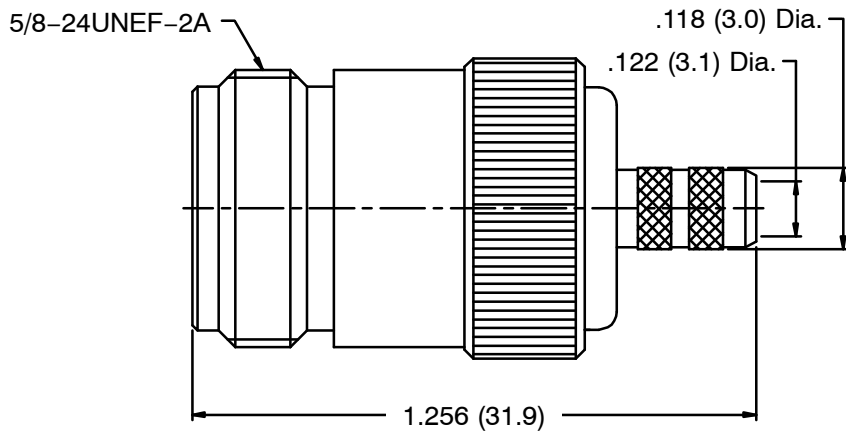

Crimped Ferrule
Hex Crimp Size .213 (5.4)
Crimped Contact Pin
Hex Crimp Size .100 (2.54)

RoHS Compliant

- NOTES: Finish (Plating Thickness in Micro-inches)
1. Brass
 2. Albaloy Plating (Copper-Tin-Zinc) Pl. 80 Min. Thick
 3. Phosphor Bronze
 4. Gold Pl. 3 Min Thick over Nickel Pl. 50 Min. Thick
over Copper Pl. 50 Min. Thick
 5. TEFLON

Dimensions are in Inches		Part No.	
Unless Otherwise Specified Tolerances		Approved	Date
0.5-6 = ±0.2			12-14-2018
6-30 = ±0.4		Checked	Date
30-120 = ±0.6			12-14-2018
120-315 = ±1		Drawn	Date
315-1000 = ±1.6			12-14-2018
1000-2000 = ±2.4			
No.	Description	Material	Finish
			Q'ty
		Drawing No.	Scale
			2.5/1
		Issue	A

<h1>NTE Electronics</h1>	
Title	N Crimp Jack (For RG-58C/U Cable)
Drawing No.	06-N009
File No.	

5	Ferrule	Note 1	Note 2	1	
4	Contact Pin	Note 3	Note 4	1	
3	Barrel	Note 1	Note 2	1	
2	Insulator	Note 5	Natural	1	
1	Body	Note 1	Note 2	1	
No.	Description	Material	Finish	Q'ty	Drawing No.

1 2 3 4 5 6 7 8