

**GENERAL DESCRIPTION**

The 73S1210F is a versatile and economical CMOS System-on-Chip device intended for smart card reader applications. The circuit is built around an 80515 high-performance core; it features primarily an ISO-7816 / EMV interface and a generic asynchronous serial interface. Delivered with turnkey Teridian embedded firmware, it forms a ready-to-use smart card reader solution that can be seamlessly incorporated into any microprocessor-based system where a serial line is available.

The solution is scalable, thanks to a built-in I<sup>2</sup>C interface that allows to drive external electrical smart card interfaces such as Teridian 73S8010 ICs. This makes the solution immediately able to support multi-card slots or multi-SAM architectures.

In addition, the 73S1210 features a 5x6 PINpad interface, 8 user I/Os, multiple interrupt options and an analog voltage input (for DC voltage monitoring such as battery level detection) that make it suitable for low-cost PINpad reader devices.

The 80515 CPU core instruction set is compatible with the industry standard 8051, while offering one clock-cycle per instruction processing power (most instructions). With a CPU clock running up to 24MHz, it results in up to 24MIPS available that meets the requirements of various encryption needs such as AES, DES / 3-DES and even RSA (for PIN encryption for instance).

The circuit requires a single 6MHz to 12MHz crystal.

The respective 73S1210F embedded memories are 32KB Flash program memory, 2KB user XRAM memory, and 256B IRAM memory. Dedicated FIFOs for the ISO 7816 UART are independent from the user XRAM and IRAM.

Alternatively to the turnkey firmware offered by Teridian, customers can develop their own embedded firmware directly within their application or using Teridian 73S1210F Evaluation Board through a JTAG-like interface.

The chip incorporates an inductor-based DC-DC converter that generates all the necessary voltages to the various 73S1210F function blocks (smart card interface, digital core, etc.) from any of two distinct power supply sources: the +5V bus ( $V_{BUS}$ , 4.4 to 6.5V), or a main battery ( $V_{BAT}$ , 4.0V to 6.5V). The chip automatically powers-up the DC-DC converter with  $V_{BUS}$  if it is present, or uses  $V_{BAT}$  as the supply input if  $V_{BUS}$  is not present. Alternatively, the pin  $V_{PC}$  can support a wider power supply input range (2.7V to 6.5V), when using a single system supply source.

In addition, the circuit features an ON/OFF mode which operates directly with an ON/OFF system switch: Any activity on the ON/OFF button is debounced internally and controls the power generation circuit accordingly, under the supervision of the firmware (OFF request / OFF acknowledgement at firmware level). The OFF mode can be alternatively initiated from the controller (firmware action instead of ON/OFF switch).

In OFF mode, the circuit typically draws less than 1 $\mu$ A, which makes it ideal for applications where battery life must be maximized.

Embedded Flash memory is in-system programmable and lockable by means of on-silicon fuses. This makes the 73S1210F suitable for both development and production phases.

Teridian Semiconductor Corporation offers with its 73S1210F a very comprehensive set of software libraries for EMV. Refer to the *73S12xxF Software User's Guide* for a complete description of the Application Programming Interface (API Libraries) and related software modules.

A complete array of development and programming tools, libraries and demonstration boards enable rapid development and certification of readers that meet most demanding smart card standards.

**APPLICATIONS**

- PINpad smart card readers:
  - With serial connectivity
  - Ideal for low-cost POS Terminals and Digital Identification (Secure Login, Gov't ID, ...)
- SIM Readers in Personal Wireless devices
- Payphones & Vending machines
- General purpose smart card readers

**ADVANTAGES**

- Reduced BOM
- Versatile power supply options
  - 2.7V to 6.5V ranges
- Higher performance CPU core (up to 24MIPS)
- Built-in EMV/ISO slot, expandable to multi-slots
- Flexible power supply options
  - On-chip DC-DC converter
  - CMOS switches between supply inputs
- Sub- $\mu$ A Power Down mode with ON/OFF switch
- Powerful In-Circuit Emulation and Programming
- A complete set of EMV4.1 / ISO7816 libraries
- Turnkey PC/SC firmware and host drivers
  - Multiple OS supported

## FEATURES

### 80515 Core:

- 1 clock cycle per instruction (most instructions)
- CPU clocked up to 24MHz
- 32KB Flash memory (lockable)
- 2kB XRAM (User Data Memory)
- 256 byte IRAM
- Hardware watchdog timer

### Oscillators:

- Single low-cost 6MHz to 12MHz crystal
- An Internal PLL provides all the necessary clocks to each block of the system

### Interrupts:

- Standard 80C515 4-priority level structure
- 9 different sources of interrupt to the core

### Power Down Modes:

- 2 standard 80C515 Power Down and IDLE modes
- Sub- $\mu$ A OFF mode
- ON/OFF Main System Power Switch:
- Input for an SPST momentary switch to ground

### Timers:

- (2) Standard 80C52 timers T0 and T1
- (1) 16-bit timer

### Built-in ISO-7816 Card Interface:

- Linear regulator produces VCC for the card (1.8V, 3V or 5V)
- Full compliance with EMV 4.1
- Activation/Deactivation sequencers
- Auxiliary I/O lines (C4 and C8 signals)
- 7kV ESD protection on all interface pins

### Communication with Smart Cards:

- ISO 7816 UART 9600 to 115kbps for T=0, T=1
- (2) 2-Byte FIFOs for transmit and receive
- Configured to drive multiple external Teridian 73S8010x interfaces (for multi-SAM architectures)

### Voltage Detection:

- Analog Input (detection range: 1.0V to 2.5V)

### Communication Interfaces:

- Full-duplex serial interface (1200 to 115kbps UART)
- I<sup>2</sup>C Master Interface (400kbps)
- Man-Machine Interface and I/Os:
- 6x5 Keyboard (hardware scanning, debouncing and scrambling)
- (8) User I/Os
- Single programmable current output (LED)
- Operating Voltage:
- Single supply 2.7V to 6.5V operation (VPC)
- 5V supply (VBUS 4.4V to 5.5V) with or without battery back up operation (VBAT 4.0V to 6.5V)
- Automated detection of voltage presence - Priority on VBUS over VBAT

### DC-DC Converter:

- Requires a single 10 $\mu$ H Inductor
- 3.3V / 20mA supply available for external circuits

### Operating Temperature:

- -40°C to 85°C

### Package:

- 68-pin QFN, 44 pin QFN

### Turnkey Firmware:

- Compliant with PC/SC, ISO7816 and EMV4.1 specifications
- Features a Power Down mode accessible from the host
- Supports Plug & Play over serial interface
- Windows<sup>®</sup> XP driver available (\*)
- Windows CE / Mobile driver available (\*)
- Linux and other OS: Upon request
- Or for custom developments:
  - A complete set of ISO-7816, EMV4.1 and low-level libraries are available for T=0 / T=1
  - Two-level Application Programming Interface (ANSI C-language libraries)

(\*) Contact Teridian Semiconductor for conditions and availability.

## Table of Contents

<b>1</b>	<b>Hardware Description.....</b>	<b>8</b>
1.1	Pin Description.....	8
1.2	Hardware Overview.....	11
1.3	80515 MPU Core.....	11
1.3.1	80515 Overview.....	11
1.3.2	Memory Organization.....	11
1.4	Program Security.....	16
1.5	Special Function Registers (SFRs).....	18
1.5.1	Internal Data Special Function Registers (SFRs).....	18
1.5.2	IRAM Special Function Registers (Generic 80515 SFRs).....	19
1.5.3	External Data Special Function Registers (SFRs).....	20
1.6	Instruction Set.....	22
1.7	Peripheral Descriptions.....	22
1.7.1	Oscillator and Clock Generation.....	22
1.7.2	Power Supply Management.....	25
1.7.3	Power ON/OFF.....	26
1.7.4	Power Control Modes.....	27
1.7.5	Interrupts.....	33
1.7.6	UART.....	40
1.7.7	Timers and Counters.....	45
1.7.8	WD Timer (Software Watchdog Timer).....	47
1.7.9	User (USR) Ports.....	49
1.7.10	Analog Voltage Comparator.....	51
1.7.11	LED Driver.....	53
1.7.12	I <sup>2</sup> C Master Interface.....	54
1.7.13	Keypad Interface.....	61
1.7.14	Emulator Port.....	68
1.7.15	Smart Card Interface Function.....	69
1.7.16	VDD Fault Detect Function.....	103
<b>2</b>	<b>Typical Application Schematic.....</b>	<b>104</b>
<b>3</b>	<b>Electrical Specification.....</b>	<b>105</b>
3.1	Absolute Maximum Ratings.....	105
3.2	Recommended Operating Conditions.....	105
3.3	Digital IO Characteristics.....	106
3.4	Oscillator Interface Requirements.....	107
3.5	DC Characteristics: Analog Input.....	107
3.6	Smart Card Interface Requirements.....	108
3.7	DC Characteristics.....	110
3.8	Current Fault Detection Circuits.....	111
<b>4</b>	<b>Equivalent Circuits.....</b>	<b>112</b>
<b>5</b>	<b>Package Pin Designation.....</b>	<b>120</b>
5.1	68-pin QFN Pinout.....	120
5.2	44-pin QFN Pinout.....	121
<b>6</b>	<b>Packaging Information.....</b>	<b>122</b>
6.1	68-Pin QFN Package Outline.....	122
6.2	44-Pin QFN Package Outline.....	123
<b>7</b>	<b>Ordering Information.....</b>	<b>124</b>
<b>8</b>	<b>Related Documentation.....</b>	<b>124</b>
<b>9</b>	<b>Contact Information.....</b>	<b>124</b>
	<b>Revision History.....</b>	<b>125</b>

## Figures

Figure 1: IC Functional Block Diagram .....	7
Figure 2: Memory Map .....	15
Figure 3: Clock Generation and Control Circuits .....	22
Figure 4: Oscillator Circuit.....	24
Figure 5: Detailed Power Management Logic Block Diagram .....	25
Figure 6: Power Down Control.....	27
Figure 7: Detail of Power Down Interrupt Logic .....	28
Figure 8: Power Down Sequencing .....	29
Figure 9: External Interrupt Configuration.....	33
Figure 10: I <sup>2</sup> C Write Mode Operation.....	55
Figure 11: I <sup>2</sup> C Read Operation .....	56
Figure 12: Simplified Keypad Block Diagram .....	61
Figure 13: Keypad Interface Flow Chart .....	63
Figure 14: Smart Card Interface Block Diagram.....	69
Figure 15: External Smart Card Interface Block Diagram .....	70
Figure 16: Asynchronous Activation Sequence Timing .....	73
Figure 17: Deactivation Sequence.....	73
Figure 18: Smart Card CLK and ETU Generation .....	74
Figure 19: Guard, Block, Wait and ATR Time Definitions .....	75
Figure 20: Synchronous Activation .....	77
Figure 21: Example of Sync Mode Operation: Generating/Reading ATR Signals .....	77
Figure 22: Creation of Synchronous Clock Start/Stop Mode Start Bit in Sync Mode .....	78
Figure 23: Creation of Synchronous Clock Start/Stop Mode Stop Bit in Sync Mode .....	78
Figure 24: Operation of 9-bit Mode in Sync Mode .....	79
Figure 25: 73S1210F Typical Application Schematic .....	104
Figure 26: 12 MHz Oscillator Circuit .....	112
Figure 27: 32KHz Oscillator Circuit.....	112
Figure 28: Digital I/O Circuit.....	113
Figure 29: Digital Output Circuit.....	113
Figure 30: Digital I/O with Pull Up Circuit.....	114
Figure 31: Digital I/O with Pull Down Circuit .....	114
Figure 32: Digital Input Circuit.....	115
Figure 33: OFF_REQ Interface Circuit .....	115
Figure 34: Keypad Row Circuit .....	115
Figure 35: Keypad Column Circuit .....	116
Figure 36: LED Circuit.....	116
Figure 37: Test and Security Pin Circuit .....	117
Figure 38: Analog Input Circuit .....	117
Figure 39: Smart Card Output Circuit .....	117
Figure 40: Smart Card I/O Circuit .....	118
Figure 41: PRES Input Circuit.....	118
Figure 42: PRESB Input Circuit .....	118
Figure 43: ON_OFF Input Circuit.....	119
Figure 44: 73S1210F 68 QFN Pinout .....	120
Figure 45: 73S1210F 44 QFN Pinout .....	121
Figure 46: 73S1210F 68 QFN Mechanical Drawing.....	122
Figure 47: 73S1210F 44 QFN Package Drawing .....	123

## Tables

Table 1: 73S1210 Pinout Description .....	8
Table 2: MPU Data Memory Map .....	11
Table 3: Flash Special Function Registers .....	13
Table 4: Internal Data Memory Map .....	14
Table 5: Program Security Registers .....	17
Table 6: IRAM Special Function Registers Locations .....	18
Table 7: IRAM Special Function Registers Reset Values .....	19
Table 8: XRAM Special Function Registers Reset Values .....	20
Table 9: PSW Register .....	21
Table 10: Port Registers .....	21
Table 11: Frequencies and Mcount Values for MCLK = 96MHz .....	23
Table 12: The MCLKCtl Register .....	23
Table 13: The TCON Register .....	24
Table 14: The INT5Ctl Register .....	30
Table 15: The MISCTl0 Register .....	30
Table 16: The MISCTl1 Register .....	31
Table 17: The MCLKCtl Register .....	31
Table 18: The PCON Register .....	32
Table 19: The IEN0 Register .....	34
Table 20: The IEN1 Register .....	35
Table 21: The IEN2 Register .....	35
Table 22: The TCON Register .....	36
Table 23: The T2CON Register .....	36
Table 24: The IRCON Register .....	37
Table 25: External MPU Interrupts .....	37
Table 26: Control Bits for External Interrupts .....	38
Table 27: Priority Level Groups .....	38
Table 28: The IP0 Register .....	38
Table 29: The IP1 Register .....	39
Table 30: Priority Levels .....	39
Table 31: Interrupt Polling Sequence .....	39
Table 32: Interrupt Vectors .....	39
Table 33: UART Modes .....	40
Table 34: Baud Rate Generation .....	40
Table 35: The PCON Register .....	41
Table 36: The BRCON Register .....	41
Table 37: The MISCTl0 Register .....	42
Table 38: The S0CON Register .....	43
Table 39: The S1CON Register .....	44
Table 40: The TMOD Register .....	45
Table 41: Timers/Counters Mode Description .....	45
Table 42: The TCON Register .....	46
Table 43: The IEN0 Register .....	47
Table 44: The IEN1 Register .....	48
Table 45: The IP0 Register .....	48
Table 46: The WDTREL Register .....	48
Table 47: Direction Registers and Internal Resources for DIO Pin Groups .....	49
Table 48: UDIR Control Bit .....	49
Table 49: Selectable Controls Using the UxIS Bits .....	49
Table 50: The USRIntCtl1 Register .....	50
Table 51: The USRIntCtl2 Register .....	50
Table 52: The USRIntCtl3 Register .....	50
Table 53: The USRIntCtl4 Register .....	50
Table 54: The ACOMP Register .....	51
Table 55: The INT6Ctl Register .....	52
Table 56: The LEDCtl Register .....	53

Table 57: The DAR Register .....	57
Table 58: The WDR Register.....	57
Table 59: The SWDR Register .....	58
Table 60: The RDR Register.....	58
Table 61: The SRDR Register .....	59
Table 62: The CSR Register.....	59
Table 63: The INT6Ctl Register .....	60
Table 64: The KCOL Register.....	64
Table 65: The KROW Register .....	64
Table 66: The KSCAN Register .....	65
Table 67: The KSTAT Register .....	65
Table 68: The KSIZE Register .....	66
Table 69: The KORDERL Register .....	67
Table 70: The KORDERH Register .....	67
Table 71: The INT5Ctl Register .....	68
Table 72: The SCSel Register .....	80
Table 73: The SCInt Register .....	81
Table 74: The SCIE Register .....	82
Table 75: The VccCtl Register .....	83
Table 76: The VccTmr Register .....	84
Table 77: The CRDCtl Register .....	85
Table 78: The STXCtl Register .....	86
Table 79: The STXData Register.....	87
Table 80: The SRXCtl Register.....	87
Table 81: The SRXData Register .....	88
Table 82: The SCCtl Register .....	89
Table 83: The SCECtl Register.....	90
Table 84: The SCDIR Register .....	91
Table 85: The SPrtcol Register.....	92
Table 86: The SCCLK Register .....	93
Table 87: The SCECLK Register .....	93
Table 88: The SParCtl Register .....	94
Table 89: The SByteCtl Register .....	95
Table 90: The FDRReg Register .....	96
Table 91: The FDRReg Bit Functions.....	96
Table 92: Divider Ratios Provided by the ETU Counter .....	96
Table 93: Divider Values for the ETU Clock .....	97
Table 94: The CRCMsB Register .....	98
Table 95: The BGT Register .....	99
Table 96: The EGT Register .....	99
Table 97: The BWTB0 Register .....	100
Table 98: The BWTB1 Register .....	100
Table 99: The BWTB2 Register .....	100
Table 100: The BWTB3 Register .....	100
Table 101: The CWTB0 Register.....	100
Table 102: The CWTB1 Register.....	100
Table 103: The ATRLsB Register .....	101
Table 104: The ATRMsB Register .....	101
Table 105: The STSTO Register .....	101
Table 106: The RLength Register.....	101
Table 107: Smart Card SFR Table .....	102
Table 108: The VDDFCtl Register .....	103
Table 109: Order Numbers and Packaging Marks .....	124

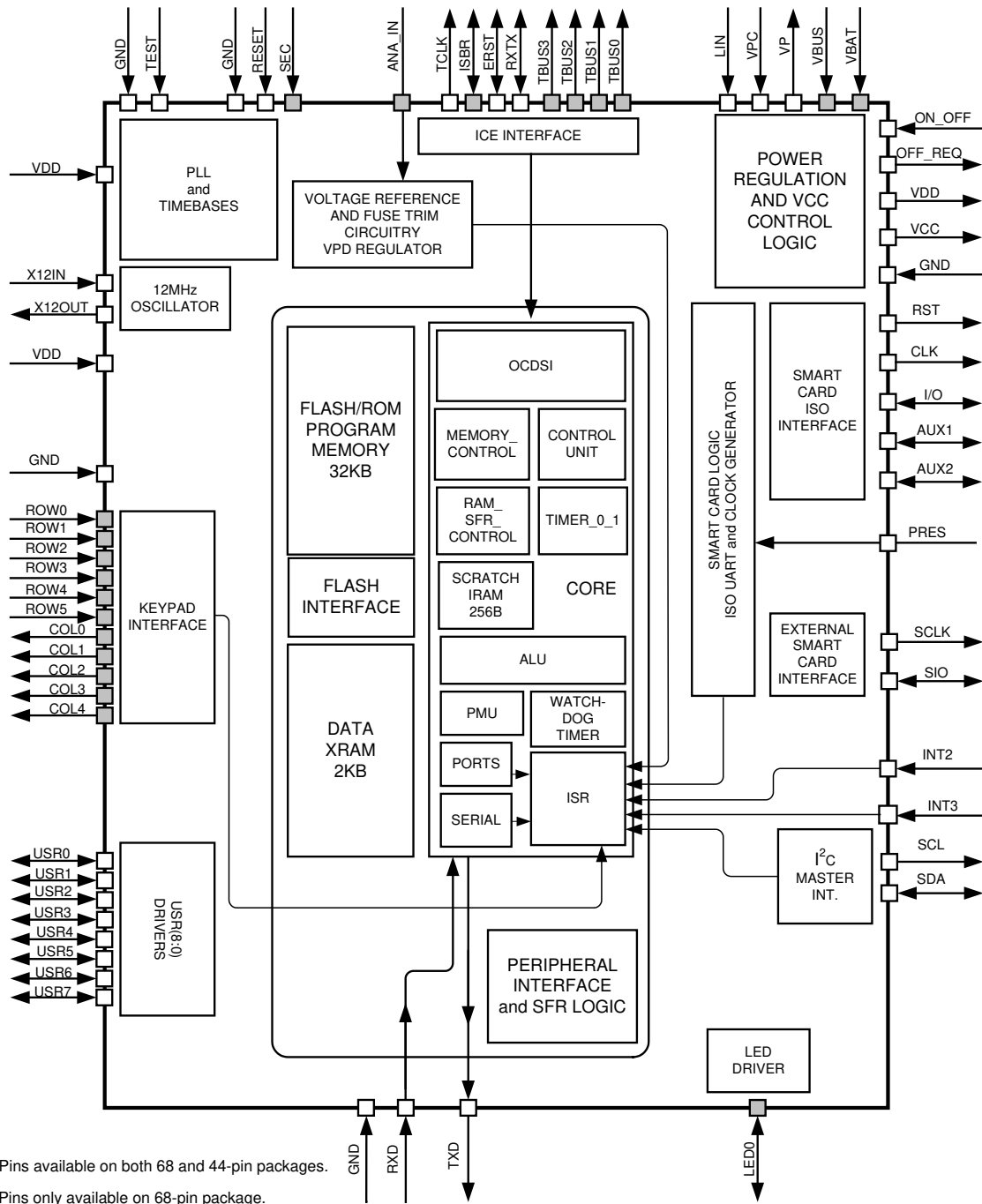


Figure 1: IC Functional Block Diagram

# 1 Hardware Description

## 1.1 Pin Description

Table 1: 73S1210 Pinout Description

Pin Name	Pin (68 QFN)	Pin (44 QFN)	Type	Equivalent Circuit*	Description
X12IN	10	9	I	<a href="#">Figure 26</a>	MPU clock crystal oscillator input pin. A 1M $\Omega$ resistor is required between pins X12IN and X12OUT.
X12OUT	11	10	O	<a href="#">Figure 26</a>	MPU clock crystal oscillator output pin.
ROW(5:0) 0 1 2 3 4 5	21 22 24 33 36 37		I	<a href="#">Figure 34</a>	Keypad row input sense.
COL(4:0) 0 1 2 3 4	12 13 14 16 19		O	<a href="#">Figure 35</a>	Keypad column output scan pins.
USR(7:0) 0 1 2 3 4 5 6 7	35 34 32 31 30 29 23 20	22 21 20 19 18 17 14 13	IO	<a href="#">Figure 30</a>	General-purpose user pins, individually configurable as inputs or outputs or as external input interrupt ports.
SCL	5	6	O	<a href="#">Figure 29</a>	I <sup>2</sup> C (master mode) compatible Clock signal. Note: the pin is configured as an open drain output. When the I2C interface is being used, an external pull up resistor is required. A value of 3K is recommended.
SDA	6	7	IO	<a href="#">Figure 28</a>	I <sup>2</sup> C (master mode) compatible data I/O. Note: this pin is bi-directional. When the pin is configured as output, it is an open drain output. When the I2C interface is being used, an external pull up resistor is required. A value of 3K is recommended.
RXD	17	11	I	<a href="#">Figure 32</a>	Serial UART Receive data pin.
TXD	18	12	O	<a href="#">Figure 29</a>	Serial UART Transmit data pin.
INT3	48	30	I	<a href="#">Figure 32</a>	General purpose interrupt input.
INT2	49	31	I	<a href="#">Figure 32</a>	General purpose interrupt input.
SIO	47	29	IO	<a href="#">Figure 28</a>	IO data signal for use with external Smart Card interface circuit such as 73S8010.
SCLK	45	28	O	<a href="#">Figure 29</a>	Clock signal for use with external Smart Card interface circuit.



Pin Name	Pin (68 QFN)	Pin (44 QFN)	Type	Equivalent Circuit*	Description
PRES	53	34	I	<a href="#">Figure 41</a>	Smart Card presence. Active high. Note: the pin has a very weak pull down resistor. In noisy environments, an external pull down may be desired to insure against a false card event.
CLK	55	36	O	<a href="#">Figure 39</a>	Smart Card clock signal.
RST	57	38	O	<a href="#">Figure 39</a>	Smart Card reset signal.
IO	61	42	IO	<a href="#">Figure 40</a>	Smart Card Data IO signal.
AUX1	60	41	IO	<a href="#">Figure 40</a>	Auxiliary Smart Card IO signal (C4).
AUX2	59	40	IO	<a href="#">Figure 40</a>	Auxiliary Smart Card IO signal (C8).
VCC	58	39	PSO		Smart Card VCC supply voltage output. A 0.47 $\mu$ F capacitor is required and should be located at the smart card connector. The capacitor should be a ceramic type with low ESR.
GND	56	37	GND		Smart Card Ground.
VPC	65	44	PSI		Power supply source for main voltage converter circuit. A 10 $\mu$ F and a 0.1 $\mu$ F capacitor are required at the VPC input. The 10 $\mu$ F capacitor should be a ceramic type with low ESR.
VBUS	62		PSI		Alternate power source input from external power supply.
VBAT	64		PSI		Alternate power source input, typically from two series cells, V > 4V.
VP	54	35	PSO		Intermediate output of main converter circuit. Requires an external 4.7 $\mu$ F low ESR filter capacitor to GND.
LIN	66	1	PSI		Connection to 10 $\mu$ H inductor for internal step up converter. Note: inductor must be rated for 400 mA maximum peak current.
ON_OFF	63	43	I	<a href="#">Figure 43</a>	Power control pin. Connected to normally open SPST switch to ground. Closing switch for duration greater than debounce period will turn 73S1210F on. If 73S1210F is on, closing switch will flag the 73S1210F to go to the off state. Firmware will control when the power is shut down.
OFF_REQ	52	33	O	<a href="#">Figure 33</a>	Digital output. If ON_OFF switch is closed (to ground) for debounce duration and circuit is "on," OFF_REQ will go high (Request to turn OFF). This output should be connected to an interrupt pin to signal the CPU core that a request to shut down power has been initiated. The firmware can then perform all of its shut down housekeeping duties before shutting down V <sub>DD</sub> .
TBUS(3:0)			IO		Trace bus signals for ICE.
0	50				
1	46				
2	44				
3	41				

Pin Name	Pin (68 Qfn)	Pin (44 QFN)	Type	Equivalent Circuit*	Description
RXTX	43	27	IO		ICE control.
ERST	38	23	IO		ICE control.
ISBR	3		IO		ICE control.
TCLK	39	24	I		ICE control.
ANA_IN	15		AI	<a href="#">Figure 38</a>	Analog input pin. This signal goes to a programmable comparator and is used to sense the value of an external voltage.
SEC	2		I	<a href="#">Figure 37</a>	Input pin for use in programming security fuse. It should be connected to ground when not in use.
TEST	51	32	DI	<a href="#">Figure 37</a>	Test pin, should be connected to ground
LED0	4	5	IO	<a href="#">Figure 36</a>	Special output driver, programmable pull-down current to drive LED. May also be used as an input.
VDD	68 28 40	3 16 25	PSO		V <sub>DD</sub> supply output pin. A 0.1μF capacitor is recommended at each VDD pin.
N/C	7 8 26 27				No connect.
GND	9 25 42 67	2 8 15 26	GND		General ground supply pins for all IO and logic circuits.
RESET	1	4	I	<a href="#">Figure 32</a>	Reset input, positive assertion. Resets logic and registers to default condition. Note: to insure proper reset operation after V <sub>DD</sub> is turned on by application of V <sub>BUS</sub> power or activation of the ON/OFF switch, external reset circuitry must generate a proper reset signal to the 73S1210F. This can be accomplished via a simple RC network.

\* See the figures in the [Equivalent Circuits](#) section.

## 1.2 Hardware Overview

The 73S1210F single smart card controller integrates all primary functional blocks required to implement a smart card reader. Included on chip are an 8051-compatible microprocessor (MPU) which executes up to one instruction per clock cycle (80515), a fully integrated ISO 7816 compliant smart card interface, expansion smart card interface, serial interface, I2C interface, 6 x 5 keypad interface, RAM, FLASH memory, and a variety of I/O pins.

The power management circuitry provides a 3.3V voltage output (VDD, pin #68) that must be connected to the power supply inputs of the digital core of the circuit, pins # 28 and 40 (these are not internally connected). Should external circuitry require a 3.3V digital power supply, the VDD output is capable of supplying additional current.

Figure 1 shows a functional block diagram of the 73S1210F.

## 1.3 80515 MPU Core

### 1.3.1 80515 Overview

The 73S1210F includes an 80515 MPU (8-bit, 8051-compatible) that performs most instructions in one clock cycle. The 80515 architecture eliminates redundant bus states and implements parallel execution of fetch and execution phases. Normally a machine cycle is aligned with a memory fetch, therefore, most of the 1-byte instructions are performed in a single cycle. This leads to an 8x performance (average) improvement (in terms of MIPS) over the Intel 8051 device running at the same clock frequency.

Actual processor clocking speed can be adjusted to the total processing demand of the application (cryptographic calculations, key management, memory management, and I/O management) using the XRAM special function register `MPUCKCtl`.

Typical smart card, serial, keyboard and I2C management functions are available for the MPU as part of the Teridian standard library. A standard ANSI "C" 80515-application programming interface library is available to help reduce design cycle. Refer to the *73S12xxF Software User's Guide*.

### 1.3.2 Memory Organization

The 80515 MPU core incorporates the Harvard architecture with separate code and data spaces. Memory organization in the 80515 is similar to that of the industry standard 8051. There are three memory areas: Program memory (Flash), external data memory (XRAM), and internal data memory (IRAM). Data bus address space is allocated to on-chip memory as shown Table 2

**Table 2: MPU Data Memory Map**

Address (hex)	Memory Technology	Memory Type	Typical Usage	Memory Size (bytes)
0000-7FFF	Flash Memory	Non-volatile	Program and non-volatile data	32KB
0000-07FF	Static RAM	Volatile	MPU data XRAM	2KB
FC00-FFFF	External SFR	Volatile	Peripheral control	1KB

Note: The IRAM is part of the core and is addressed differently.

**Program Memory:** The 80515 can address up to 32KB of program memory space from 0x0000 to 0xFFFF. Program memory is read when the MPU fetches instructions or performs a MOV<sub>C</sub> operation. After reset, the MPU starts program execution from location 0x0000. The lower part of the program memory includes reset and interrupt vectors. The interrupt vectors are spaced at 8-byte intervals, starting from 0x0003. Reset is located at 0x0000.

**Flash Memory:** The program memory consists of flash memory. The flash memory is intended to primarily contain MPU program code. Flash erasure is initiated by writing a specific data pattern to

specific SFR registers in the proper sequence. These special pattern/sequence requirements prevent inadvertent erasure of the flash memory.

The mass erase sequence is:

1. Write 1 to the FLSH\_MEEN bit in the **FLSHCTL** register (SFR address 0xB2[1]).
2. Write pattern 0xAA to **ERASE** (SFR address 0x94).

Note: The mass erase cycle can only be initiated when the ICE port is enabled.

The page erase sequence is:

1. Write the page address to **PGADDR** (SFR address 0xB7[7:1]).
2. Write pattern 0x55 to **ERASE** (SFR address 0x94).

The PGADDR register denotes the page address for page erase. The page size is 512 (200h) bytes and there are 128 pages within the flash memory. The **PGADDR** denotes the upper seven bits of the flash memory address such that bit 7:1 of the **PGADDR** corresponds to bit 15:9 of the flash memory address. Bit 0 of the PGADDR is not used and is ignored. The MPU may write to the flash memory. This is one of the non-volatile storage options available to the user. The **FLSHCTL** SFR bit FLSH\_PWE (flash program write enable) differentiates 80515 data store instructions (MOVX@DPTR,A) between Flash and XRAM writes. Before setting FLSH\_PWE, all interrupts need to be disabled by setting EAL = 1. [Table 3](#) shows the location and description of the 73S1210 flash-specific SFRs.

- ✓ Any flash modifications must set the CPUCLK to operate at 3.6923 MHz (**MPUCLKCti** = 0x0C) before any flash memory operations are executed to insure the proper timing when modifying the flash memory.

**Table 3: Flash Special Function Registers**

Register	SFR Address	R/W	Description
ERASE	0x94	W	<p>This register is used to initiate either the Flash Mass Erase cycle or the Flash Page Erase cycle. Specific patterns are expected for ERASE in order to initiate the appropriate Erase cycle (default = 0x00).</p> <p>0x55 – Initiate Flash Page Erase cycle. Must be preceded by a write to PGADDR @ SFR 0xB7.</p> <p>0xAA – Initiate Flash Mass Erase cycle. Must be preceded by a write to FLSH_MEEN @ SFR 0xB2 and the debug port must be enabled.</p> <p>Any other pattern written to ERASE will have no effect.</p>
PGADDR	0xB7	R/W	<p>Flash Page Erase Address register containing the flash memory page address (page 0 through 127) that will be erased during the Page Erase cycle (default = 0x00). Note: the page address is shifted left by one bit (see detailed description above).</p> <p>Must be re-written for each new Page Erase cycle.</p>
FLSHCTL	0xB2	R/W	<p>Bit 0 (FLSH_PWE): Program Write Enable:</p> <p>0 – MOVX commands refer to XRAM Space, normal operation (default). 1 – MOVX @DPTR,A moves A to Program Space (Flash) @ DPTR.</p> <p>This bit is automatically reset after each byte written to flash. Writes to this bit are inhibited when interrupts are enabled.</p>
		W	<p>Bit 1 (FLSH_MEEN): Mass Erase Enable:</p> <p>0 – Mass Erase disabled (default). 1 – Mass Erase enabled.</p> <p>Must be re-written for each new Mass Erase cycle.</p>
		R/W	<p>Bit 6 (SECURE):</p> <p>Enables security provisions that prevent external reading of flash memory and CE program RAM. This bit is reset on chip reset and may only be set. Attempts to write zero are ignored.</p>

**Internal Data Memory:** The Internal data memory provides 256 bytes (0x00 to 0xFF) of data memory. The internal data memory address is always one byte wide and can be accessed by either direct or indirect addressing. The Special Function Registers occupy the upper 128 bytes. **This SFR area is available only by direct addressing. Indirect addressing accesses the upper 128 bytes of Internal RAM.**

The lower 128 bytes contain working registers and bit-addressable memory. The lower 32 bytes form four banks of eight registers (R0-R7). Two bits on the program memory status word (PSW) select which bank is in use. The next 16 bytes form a block of bit-addressable memory space at bit addresses 0x00-0x7F. All of the bytes in the lower 128 bytes are accessible through direct or indirect addressing. [Table 4](#) shows the internal data memory map.

**Table 4: Internal Data Memory Map**

Address	Direct Addressing	Indirect Addressing
0xFF	Special Function Registers (SFRs)	RAM
0x80		
0x7F	Byte-addressable area	
0x30		
0x2F	Byte or bit-addressable area	
0x20		
0x1F	Register banks R0...R7 (x4)	
0x00		

**External Data Memory:** While the 80515 can address up to 64KB of external data memory in the space from 0x0000 to 0xFFFF, only the memory ranges shown in Figure 2 contain physical memory. The 80515 writes into external data memory when the MPU executes a MOVX @Ri,A or MOVX @DPTR,A instruction. The MPU reads external data memory by executing a MOVX A,@Ri or MOVX A,@DPTR instruction.

There are two types of instructions, differing in whether they provide an eight-bit or sixteen-bit indirect address to the external data RAM.

In the first type (MOVX A,@Ri), the contents of R0 or R1, in the current register bank, provide the eight lower-ordered bits of address. This method allows the user access to the first 256 bytes of the 2KB of external data RAM. In the second type of MOVX instruction (MOVX A,@DPTR), the data pointer generates a sixteen-bit address.

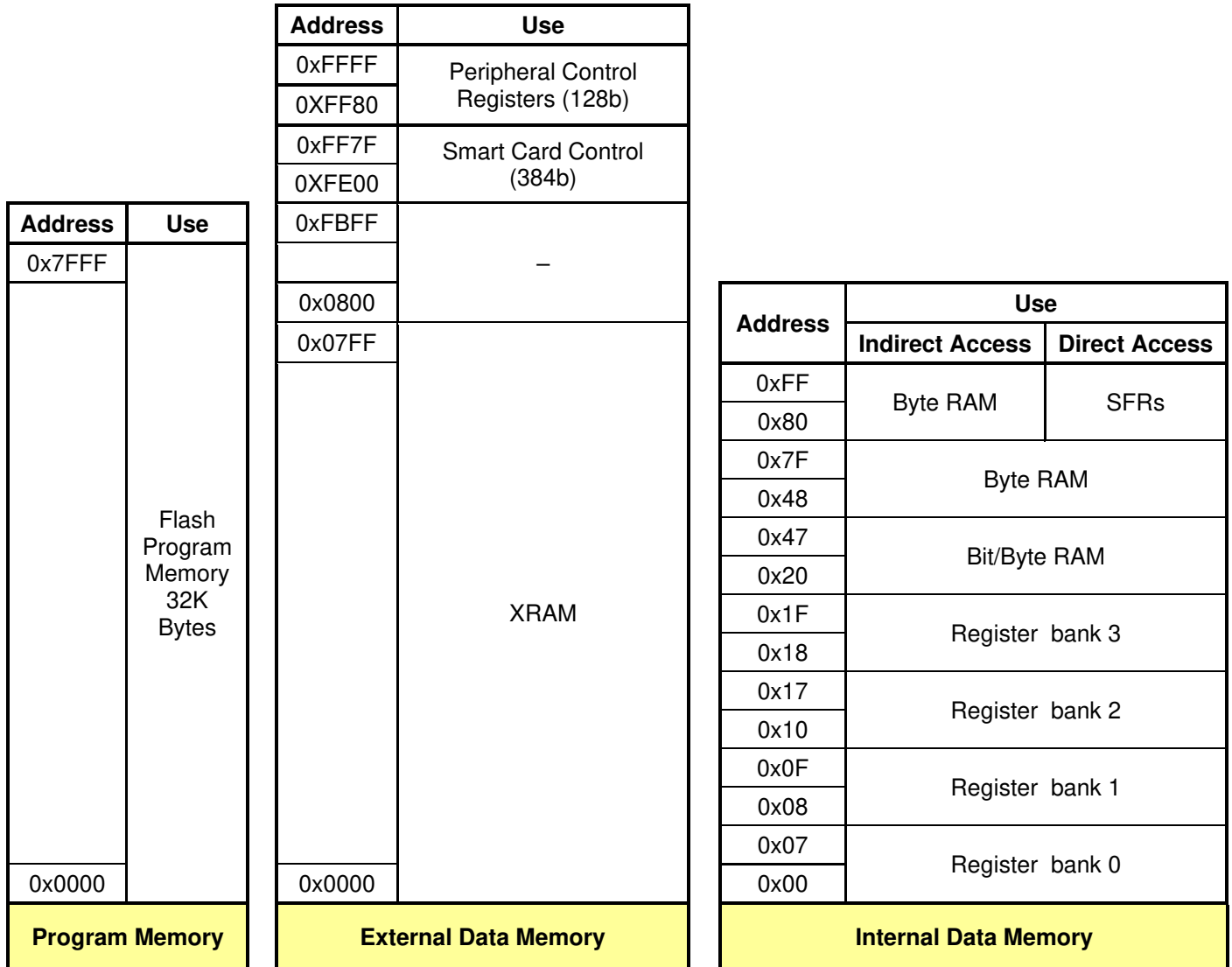


Figure 2: Memory Map

**Dual Data Pointer:** The Dual Data Pointer accelerates the block moves of data. The standard DPTR is a 16-bit register that is used to address external memory. In the 80515 core, the standard data pointer is called DPTR, the second data pointer is called DPTR1. The data pointer select bit chooses the active pointer. The data pointer select bit is located at the LSB of the **DPS** IRAM special function register (DPS.0). DPTR is selected when DPS.0 = 0 and DPTR1 is selected when DPS.0 = 1.

The user switches between pointers by toggling the LSB of the **DPS** register. All DPTR-related instructions use the currently selected DPTR for any activity.



**The second data pointer may not be supported by certain compilers.**

## 1.4 Program Security

Two levels of program and data security are available. Each level requires a specific fuse to be blown in order to enable or set the specific security mode. Mode 0 security is enabled by setting the SECURE bit (bit 6 of SFR register [FLSHCTL 0xB2](#)). Mode 0 limits the ICE interface to only allow bulk erase of the flash program memory. All other ICE operations are blocked. This guarantees the security of the user's MPU program code. Security (Mode 0) is enabled by MPU code that sets the SECURE bit. The MPU code must execute the setting of the SECURE bit immediately after a reset to properly enable Mode 0. This should be the first instruction after the reset vector jump has been executed. If the "startup.a51" assembly file is used in an application, then it must be modified to set the SECURE bit after the reset vector jump. If not using "startup.a51", then this should be the first instruction in main(). Once security Mode 0 is enabled, the only way to disable it is to perform a global erase of the flash followed by a full circuit reset. Once the flash has been erased and the reset has been executed, security Mode 0 is disabled and the ICE has full control of the core. The flash can be reprogrammed after the bulk erase operation is completed. Global erase of the flash will also clear the data XRAM memory.

The security enable bit (SECURE) is reset whenever the MPU is reset. Hardware associated with the bit only allows it to be set. As a result, the code may set the SECURE bit to enable the security Mode 0 feature but may not reset it. Once the SECURE bit is set, the code is protected and no external read of program code in flash or data (in XRAM) is possible. In order to invoke the security Mode 0, the SECSET0 (bit 1 of the XRAM SFR register [SECReg 0xFFD7](#)) fuse must be blown beforehand or the security mode 0 will not be enabled. The SECSET0 and SECSET1 fuses once blown, cannot be overridden.

Specifically, when SECURE is set:

- The ICE is limited to bulk flash erase only.
- Page zero of flash memory, the preferred location for the user's preboot code, may not be page-erased by either MPU or ICE. Page zero may only be erased with global flash erase. Note that global flash erase erases XRAM whether the SECURE bit is set or not.
- Writes to page zero, whether by MPU or ICE, are inhibited.

Security mode 1 is in effect when the SECSET1 fuse has been programmed (blown open). In security mode 1, the ICE is completely and permanently disabled. The Flash program memory and the MPU are not available for alteration, observation, nor control. As soon as the fuse has been blown, the ICE is disabled. The testing of the SECSET1 fuse will occur during the reset and before the start of pre-boot and boot cycles. This mode is not reversible, nor recoverable. In order to blow the SECSET1 fuse, the SEC pin must be held high for the fuse burning sequence to be executed properly. The firmware can check to see if this pin is held high by reading the SECPIN bit (bit 5 of XRAM SFR register [SECReg 0xFFD7](#)). If this bit is set and the firmware desires, it can blow the SECSET1 fuse. The burning of the SECSET0 does not require the SEC pin to be held high.

In order to blow the fuse for SECSET1 and SECSET0, a particular set of register writes in a specific order need to be followed. There are two additional registers that need to have a specific value written to them in order for the desired fuse to be blown. These registers are [FUSECtl \(0xFFD2\)](#) and [TRIMPCtl \(0xFFD1\)](#). The sequence for blowing the fuse is as follows:

1. Write 0x54H to [FUSECtl](#).
2. Write 0x81H for security mode 0.      Note: only program one security mode at a time.  
Write 0x82H for security mode 1.      Note: SEC pin must be high for security mode 1.
3. Write 0xA6 to [TRIMPCtl](#).
4. Delay about 500  $\mu$ s.
5. Write 0x00 to [TRIMPCtl](#) and [FUSECtl](#).



**Table 5: Program Security Registers**

Register	SFR Address	R/W	Description
FLSHCTL	0xB2	R/W	Bit 0 (FLSH_PWE): Program Write Enable: 0 – MOVX commands refer to XRAM Space, normal operation (default). 1 – MOVX @DPTR,A moves A to Program Space (Flash) @ DPTR.  This bit is automatically reset after each byte written to flash. Writes to this bit are inhibited when interrupts are enabled.
		W	Bit 1 (FLSH_MEEN): Mass Erase Enable: 0 – Mass Erase disabled (default). 1 – Mass Erase enabled.  Must be re-written for each new Mass Erase cycle.
		R/W	Bit 6 (SECURE): Enables security provisions that prevent external reading of flash memory and CE program RAM. This bit is reset on chip reset and may only be set. Attempts to write zero are ignored.
TRIMPctl	0xFFD1	W	0x54 value will set up for security fuse control. All other values are reserved and should not be used.
FUSEctl	0xFFD2	W	0xA6 value will cause the selected fuse to be blown. All other values will stop the burning process.
SECReg	0xFFD7	W	Bit 7 (PARAMSEC): 0 – Normal operation. 1 – Enable permanent programming of the security fuses.
		R	Bit 5 (SECPIN): Indicates the state of the SEC pin. The SEC pin is held low by a pull-down resistor. The user can force this pin high during boot sequence time to indicate to firmware that sec mode 1 is desired.
		R/W	Bit 1 (SECSET1): See the Program Security section.
		R/W	Bit 0 (SECSET0): See the Program Security section.

## 1.5 Special Function Registers (SFRs)

The 73S1210F utilizes numerous SFRs to communicate with the 73S1210Fs many peripherals. This results in the need for more SFR locations outside the direct address IRAM space (0x80 to 0xFF). While some peripherals are mapped to unused IRAM SFR locations, additional SFRs for the smart card and other peripheral functions are mapped to the top of the XRAM data space (0xFC00 to 0xFFFF).

### 1.5.1 Internal Data Special Function Registers (SFRs)

A map of the Special Function Registers is shown in Table 6.

**Table 6: IRAM Special Function Registers Locations**

Hex\Bin	X000	X001	X010	X011	X100	X101	X110	X111	Bin/ Hex
F8									FF
F0	<b>B</b>								F7
E8									EF
E0	<b>A</b>								E7
D8	<b>BRCON</b>								DF
D0	<b>PSW</b>	<b>KCOL</b>	<b>KROW</b>	<b>KSCAN</b>	<b>KSTAT</b>	<b>KSIZE</b>	<b>KORDERL</b>	<b>KORDERH</b>	D7
C8	<b>T2CON</b>								CF
C0	<b>IRCON</b>								C7
B8	<b>IEN1</b>	<b>IP1</b>	<b>S0RELH</b>	<b>S1RELH</b>					BF
B0			<b>FLSHCTL</b>					<b>PGADDR</b>	B7
A8	<b>IEN0</b>	<b>IP0</b>	<b>S0RELL</b>						AF
A0									A7
98	<b>S0CON</b>	<b>S0BUF</b>	<b>IEN2</b>	<b>S1CON</b>	<b>S1BUF</b>	<b>S1RELL</b>			9F
90	<b>USR70</b>	<b>UDIR70</b>	<b>DPS</b>		<b>ERASE</b>				97
88	<b>TCON</b>	<b>TMOD</b>	<b>TL0</b>	<b>TL1</b>	<b>TH0</b>	<b>TH1</b>		<b>MCLKCtl</b>	8F
80		<b>SP</b>	<b>DPL</b>	<b>DPH</b>	<b>DPL1</b>	<b>DPH1</b>	<b>WDTREL</b>	<b>PCON</b>	87

Only a few addresses are used, the others are not implemented. SFRs specific to the 73S1210F are shown in **bold** print (gray background). Any read access to unimplemented addresses will return undefined data, while most write access will have no effect. However, a few locations are reserved and not user configurable in the 73S1210F. **Writes to the unused SFR locations can affect the operation of the core and therefore must not be written to. This applies to all the SFR areas in both the IRAM and XRAM spaces. In addition, all unused bit locations within valid SFR registers must be left in their default (power on default) states.**

## 1.5.2 IRAM Special Function Registers (Generic 80515 SFRs)

Table 7 shows the location of the SFRs and the value they assume at reset or power-up.

**Table 7: IRAM Special Function Registers Reset Values**

Name	Location	Reset Value	Description
SP	0x81	0x07	Stack Pointer
DPL	0x82	0x00	Data Pointer Low 0
DPH	0x83	0x00	Data Pointer High 0
DPL1	0x84	0x00	Data Pointer Low 1
DPH1	0x85	0x00	Data Pointer High 1
WDTRREL	0x86	0x00	Watchdog Timer Reload register
PCON	0x87	0x00	Power Control
TCON	0x88	0x00	Timer/Counter Control
TMOD	0x89	0x00	Timer Mode Control
TL0	0x8A	0x00	Timer 0, low byte
TL1	0x8B	0x00	Timer 1, high byte
TH0	0x8C	0x00	Timer 0, low byte
TH1	0x8D	0x00	Timer 1, high byte
MCLKCtI	0x8F	0x0A	Master Clock Control
USR70	0x90	0xFF	User Port Data (7:0)
UDIR70	0x91	0xFF	User Port Direction (7:0)
DPS	0x92	0x00	Data Pointer Select Register
ERASE	0x94	0x00	Flash Erase
S0CON	0x98	0x00	Serial Port 0, Control Register
S0BUF	0x99	0x00	Serial Port 0, Data Buffer
IEN2	0x9A	0x00	Interrupt Enable Register 2
S1CON	0x9B	0x00	Serial Port 1, Control Register
S1BUF	0x9C	0x00	Serial Port 1, Data Buffer
S1RELL	0x9D	0x00	Serial Port 1, Reload Register, low byte
IEN0	0xA8	0x00	Interrupt Enable Register 0
IP0	0xA9	0x00	Interrupt Priority Register 0
S0RELL	0xAA	0xD9	Serial Port 0, Reload Register, low byte
FLSHCTL	0xB2	0x00	Flash Control
PGADDR	0xB7	0x00	Flash Page Address
IEN1	0xB8	0x00	Interrupt Enable Register 1
IP1	0xB9	0x00	Interrupt Priority Register 1
S0RELH	0xBA	0x03	Serial Port 0, Reload Register, high byte
S1RELH	0xBB	0x03	Serial Port 1, Reload Register, high byte
IRCON	0xC0	0x00	Interrupt Request Control Register
T2CON	0xC8	0x00	Timer 2 Control
PSW	0xD0	0x00	Program Status Word
KCOL	0xD1	0x1F	Keypad Column

Name	Location	Reset Value	Description
KROW	0XD2	0x3F	Keypad Row
KSCAN	0XD3	0x00	Keypad Scan Time
KSTAT	0XD4	0x00	Keypad Control/Status
KSIZE	0XD5	0x00	Keypad Size
KORDERL	0XD6	0x00	Keypad Column LS Scan Order
KORDERH	0XD7	0x00	Keypad Column MS Scan Order
BRCON	0xD8	0x00	Baud Rate Control Register (only BRCON.7 bit used)
A	0xE0	0x00	Accumulator
B	0xF0	0x00	B Register

### 1.5.3 External Data Special Function Registers (SFRs)

A map of the XRAM Special Function Registers is shown in Table 8. The smart card registers are listed separately in Table 107.

**Table 8: XRAM Special Function Registers Reset Values**

Name	Location	Reset Value	Description
DAR	0x FF80	0x00	Device Address Register (I <sup>2</sup> C)
WDR	0x FF81	0x00	Write Data Register (I <sup>2</sup> C)
SWDR	0x FF82	0x00	Secondary Write Data Register (I <sup>2</sup> C)
RDR	0x FF83	0x00	Read Data Register (I <sup>2</sup> C)
SRDR	0x FF84	0x00	Secondary Read Data Register (I <sup>2</sup> C)
CSR	0x FF85	0x00	Control and Status Register (I <sup>2</sup> C)
USRIntCtl1	0x FF90	0x00	External Interrupt Control 1
USRIntCtl2	0x FF91	0x00	External Interrupt Control 2
USRIntCtl3	0x FF92	0x00	External Interrupt Control 3
USRIntCtl4	0x FF93	0x00	External Interrupt Control 4
INT5Ctl	0x FF94	0x00	External Interrupt Control 5
INT6Ctl	0x FF95	0x00	External Interrupt Control 6
MPUCKCtl	0x FFA1	0x0C	MPU Clock Control
ACOMP	0x FFD0	0x00	Analog Compare Register
TRIMPCtl	0x FFD1	0x00	TRIM Pulse Control
FUSECtl	0x FFD2	0x00	FUSE Control
VDDFCtl	0x FFD4	0x00	VDDFault Control
SECReg	0x FFD7	0x00	Security Register
MISCtl0	0x FFF1	0x00	Miscellaneous Control Register 0
MISCtl1	0x FFF2	0x10	Miscellaneous Control Register 1
LEDCtl	0x FFF3	0xFF	LED Control Register

**Accumulator (ACC, A):** ACC is the accumulator register. Most instructions use the accumulator to hold the operand. The mnemonics for accumulator-specific instructions refer to accumulator as “A”, not ACC.

**B Register:** The B register is used during multiply and divide instructions. It can also be used as a scratch-pad register to hold temporary data.

**Program Status Word (PSW):****Table 9: PSW Register**

MSB	CV	AC	F0	RS1	RS	OV	–	P	LSB
-----	----	----	----	-----	----	----	---	---	-----

Bit	Symbol	Function																
PSW.7	CV	Carry flag.																
PSW.6	AC	Auxiliary Carry flag for BCD operations.																
PSW.5	F0	General purpose Flag 0 available for user.																
PSW.4	RS1	Register bank select control bits. The contents of RS1 and RS0 select the working register bank:																
PSW.3	RS0																	
			<table border="1"> <thead> <tr> <th>RS1/RS0</th> <th>Bank Selected</th> <th>Location</th> </tr> </thead> <tbody> <tr> <td>00</td> <td>Bank 0</td> <td>(0x00 – 0x07)</td> </tr> <tr> <td>01</td> <td>Bank 1</td> <td>(0x08 – 0x0F)</td> </tr> <tr> <td>10</td> <td>Bank 2</td> <td>(0x10 – 0x17)</td> </tr> <tr> <td>11</td> <td>Bank 3</td> <td>(0x18 – 0x1F)</td> </tr> </tbody> </table>	RS1/RS0	Bank Selected	Location	00	Bank 0	(0x00 – 0x07)	01	Bank 1	(0x08 – 0x0F)	10	Bank 2	(0x10 – 0x17)	11	Bank 3	(0x18 – 0x1F)
RS1/RS0	Bank Selected		Location															
00	Bank 0		(0x00 – 0x07)															
01	Bank 1	(0x08 – 0x0F)																
10	Bank 2	(0x10 – 0x17)																
11	Bank 3	(0x18 – 0x1F)																
PSW.2	OV	Overflow flag.																
PSW.1	F1	General purpose Flag 1 available for user.																
PSW.0	P	Parity flag, affected by hardware to indicate odd / even number of “one” bits in the Accumulator, i.e. even parity.																

**Stack Pointer:** The stack pointer (SP) is a 1-byte register initialized to 0x07 after reset. This register is incremented before PUSH and CALL instructions, causing the stack to begin at location 0x08.

**Data Pointer:** The data pointer (DPTR) is 2 bytes wide. The lower part is DPL, and the highest is DPH. It can be loaded as a 2-byte register (MOV DPTR,#data16) or as two registers (e.g. MOV DPL,#data8). It is generally used to access external code or data space (e.g. MOVC A,@A+DPTR or MOVX A,@DPTR respectively).

**Program Counter:** The program counter (PC) is 2 bytes wide initialized to 0x0000 after reset. This register is incremented during the fetching operation code or when operating on data from program memory. Note: The program counter is not mapped to the SFR area.

**Port Registers:** The I/O ports are controlled by Special Function Register [USR70](#). The contents of the SFR can be observed on corresponding pins on the chip. Writing a 1 to any of the ports (see Table 10) causes the corresponding pin to be at high level (3.3V), and writing a 0 causes the corresponding pin to be held at low level (GND). The data direction register [UDIR70](#) define individual pins as input or output pins (see the [User \(USR\) Ports](#) section for details).

**Table 10: Port Registers**

Register	SFR Address	R/W	Description
USR70	0x90	R/W	Register for User port bit 7:0 read and write operations (pins USR0...USR7).
UDIR70	0x91	R/W	Data direction register for User port bits 0:7. Setting a bit to 0 means that the corresponding pin is an output.

All ports on the chip are bi-directional. Each consists of a Latch (SFR 'USR70'), an output driver, and an input buffer, therefore the MPU can output or read data through any of these ports if they are not used for alternate purposes.

## 1.6 Instruction Set

All instructions of the generic 8051 microcontroller are supported. A complete list of the instruction set and of the associated op-codes is contained in the *73S12xxF Software User's Guide*.

## 1.7 Peripheral Descriptions

### 1.7.1 Oscillator and Clock Generation

The 73S1210F has one oscillator circuit for the main CPU clock. The main oscillator circuit is designed to operate with various crystal or external clock frequencies. An internal divider working in conjunction with a PLL and VCO provides a 96MHz internal clock within the 73S1210F. 96 MHz is the recommended frequency for proper operation of specific peripheral blocks such as the specific timers, ISO 7816 UART and interfaces, Step-up converter, and keypad. The clock generation and control circuits are shown in Figure 3.

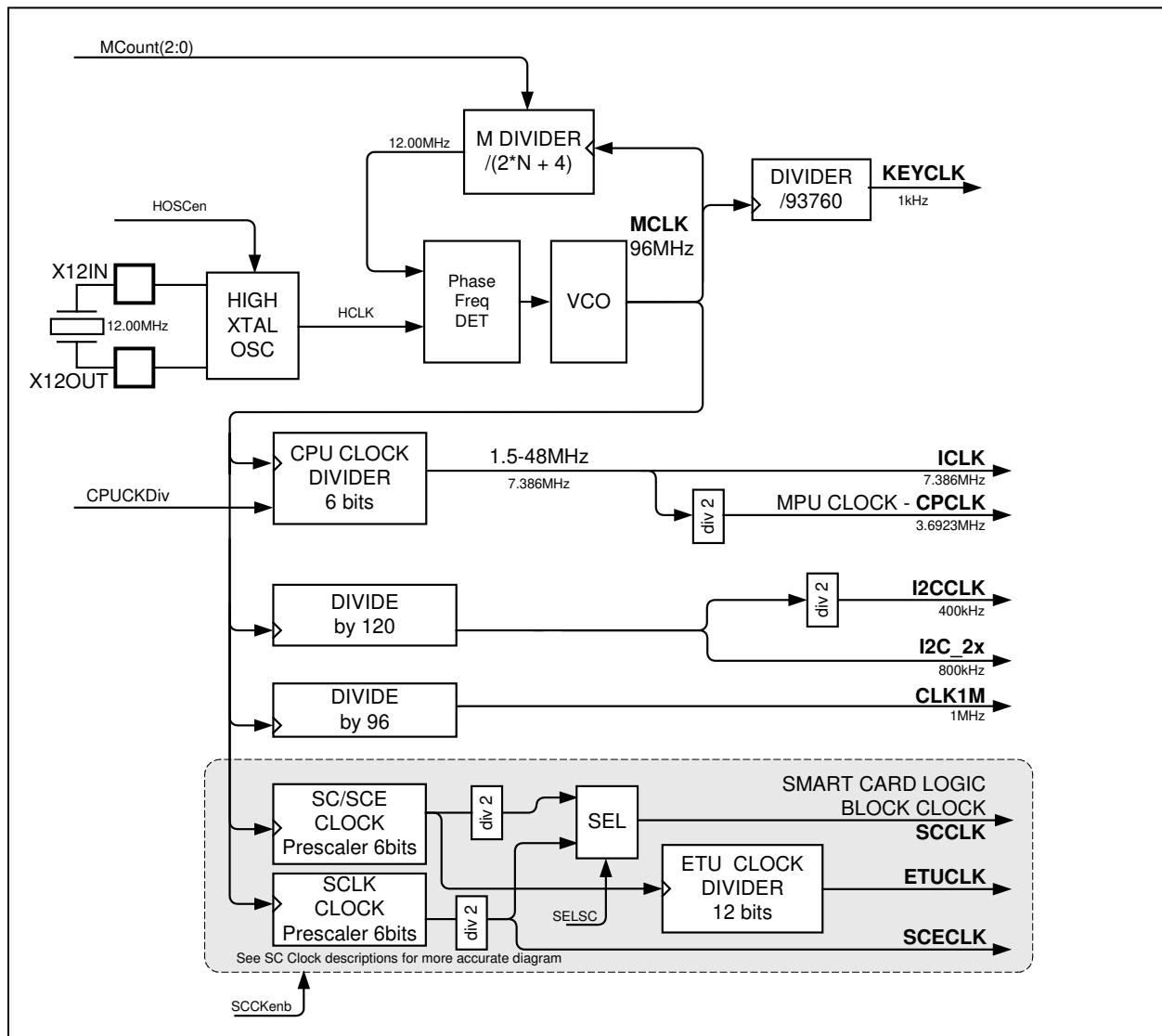


Figure 3: Clock Generation and Control Circuits

The master clock control register enables different sections of the clock circuitry and specifies the value of the VCO Mcount divider. The MCLK must be configured to operate at 96MHz to ensure proper operation of some of the peripheral blocks according to the following formula:

$$\text{MCLK} = (\text{Mcount} * 2 + 4) * F_{\text{XTAL}} = 96\text{MHz}$$

Mcount is configured in the MCLKCtl register must be bound between a value of 1 to 10. The possible crystal or external clock frequencies for getting MCLK = 96MHz are shown in Table 11.

**Table 11: Frequencies and Mcount Values for MCLK = 96MHz**

$F_{\text{XTAL}}$ (MHz)	Mcount (N)
12.00	2
9.60	3
8.00	4
6.86	5
6.00	6

#### Master Clock Control Register (MCLKCtl): 0x8F ← 0x0A

The MPU clock that drives the CPU core defaults to 3.6923MHz after reset. The MPU clock is scalable by configuring the MPU Clock Control register.

**Table 12: The MCLKCtl Register**

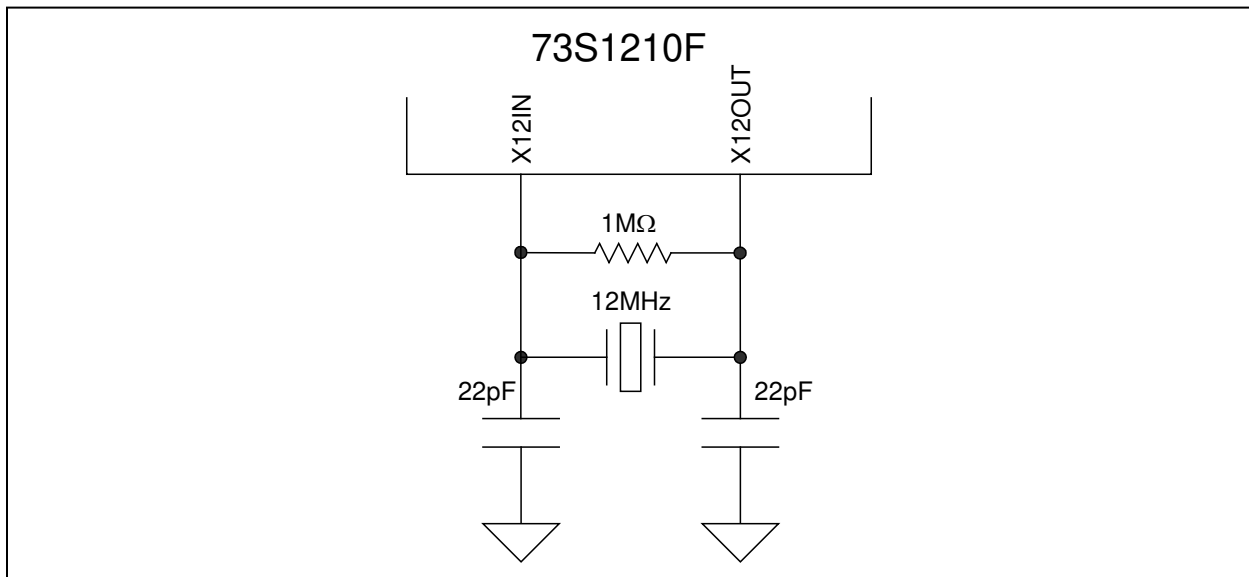
MSB				LSB			
HSOEN	KBEN	SCEN	–	–	MCT.2	MCT.1	MCT.0

Bit	Symbol	Function
MCLKCtl.7	HSOEN	High-speed oscillator disable. When set = 1, disables the high-speed crystal oscillator and VCO/PLL system. Do not set this bit = 1.
MCLKCtl.6	KBEN	1 = Disable the keypad logic clock.
MCLKCtl.5	SCEN	1 = Disable the smart card logic clock.
MCLKCtl.4	–	
MCLKCtl.3	–	
MCLKCtl.2	MCT.2	This value determines the ratio of the VCO frequency (MCLK) to the high-speed crystal oscillator frequency such that: MCLK = (MCount*2 + 4)* F <sub>XTAL</sub> . The default value is MCount = 2h such that MCLK = (2*2 + 4)*12.00MHz = 96MHz.
MCLKCtl.1	MCT.1	
MCLKCtl.0	MCT.0	

**MPU Clock Control Register (MPUCKctl): 0xFFA1 ← 0x0C****Table 13: The TCON Register**

MSB								LSB
		MDIV.5	MDIV.4	MDIV.3	MDIV.2	MDIV.1	MDIV.0	
MPUCKctl.7	–							
MPUCKctl.6	–							
MPUCKctl.5	MDIV.5	This value determines the ratio of the MPU master clock frequency to the VCO frequency (MCLK) such that $MPUCIk = MCLK / (2 * (MPUCKDiv(5:0) + 1))$ . Do not use values of 0 or 1 for MPUCKDiv(n). Default is 0Ch to set CPCLK = 3.6923MHz.						
MPUCKctl.4	MDIV.4							
MPUCKctl.3	MDIV.3							
MPUCKctl.2	MDIV.2							
MPUCKctl.1	MDIV.1							
MPUCKctl.0	MDIV.0							

The oscillator circuits are designed to connect directly to standard parallel resonant crystal in a Pierce oscillator configuration. Each side of the crystal should include a 22pF capacitor to ground for both oscillator circuits and a 1MΩ resistor is required across the 12MHz crystal.



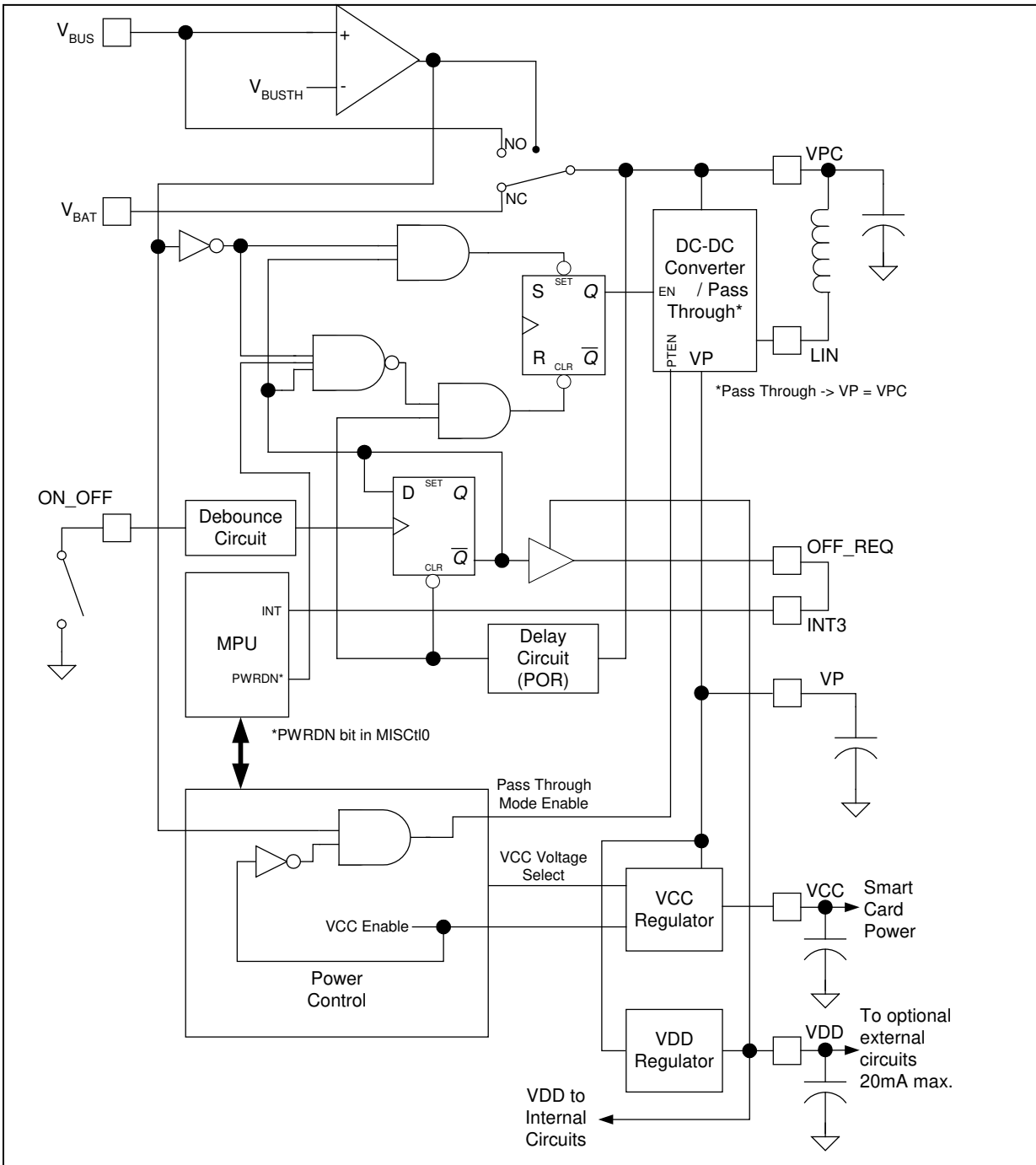
Note: The crystal should be placed as close as possible to the IC, and vias should be avoided.

**Figure 4: Oscillator Circuit**



## 1.7.2 Power Supply Management

The detailed power supply management logic block diagram is shown in Figure 5.



**Figure 5: Detailed Power Management Logic Block Diagram**

The 73S1210F contains a power supply and converter circuit that takes power from any one of three sources;  $V_{PC}$ ,  $V_{BUS}$ , or  $V_{BAT}$ .

$V_{PC}$  is specified to range from 2.7 to 6.5 volts. It can typically be supplied by a single cell battery with a voltage range of 2.7 to approximately 3.1 volts or by a standard supply of 3.3 or 5 volts.

$V_{BUS}$  is typically supplied by an external power supply and ranges in value from 4.4 to 5.5 volts (6.5V maximum).

$V_{BAT}$  is expected to be supplied from a battery of three to four series connected cells with a voltage value of 4.0 to 6.5 volts.

$V_{BAT}$  and  $V_{BUS}$  are internally switched to  $V_{PC}$  by two separate FET switches configured as a SPDT switch (break-before-make). They will not be enabled at the same time.  $V_{BUS}$  is automatically selected in lieu of  $V_{BAT}$  when  $V_{BUS}$  is present (i.e.  $V_{BUS}$  always has the priority).

If  $V_{PC}$  is provided and either  $V_{BAT}$  or  $V_{BUS}$  is also used, the source of  $V_{PC}$  must be diode isolated from the  $V_{PC}$  pin to prevent current flow from  $V_{BAT}$  or  $V_{BUS}$  into the  $V_{PC}$  source.

The power that is supplied to the  $V_{PC}$  pin (externally or internally, i.e. through  $V_{BAT}$  or  $V_{BUS}$  – see above) is up-converted to the intermediate voltage  $V_P$  utilizing an inductive, step-up converter. A series power inductor (nominal value = 10  $\mu$ H) must be connected from  $V_{PC}$  to the pin LIN, and a 10 $\mu$ F low ESR filter capacitor must be connected to  $V_{PC}$ .

$V_P$  requires a 4.7 $\mu$ F filter capacitor and will have a nominal value of 5.5 volts during normal operation.  $V_P$  is used internally by the smart card electrical interface circuit and is regulated to the desired smart card supply  $V_{CC}$  voltage (can be programmed for values of 5V, 3V, or 1.8V).

$V_P$  is also used internally to generate a 3.3V nominal, regulated power supply  $V_{DD}$ .  $V_{DD}$  is output on pin 68 and must be directly tied to all other  $V_{DD}$  pins on the 73S1210F (pins 28 and 40).  $V_{DD}$  powers all the digital logic, input/output buffering, and analog functions. It can also be used for external circuitry: up to 20mA current can be supplied to external devices simultaneously to the 73S1210F's digital core maximum consumption.

### 1.7.3 Power ON/OFF

The 73S1210F features an ON\_OFF input pin for a momentary contact, main-system ON/OFF switch. The purpose of this switch is to place the circuit in a very low-power mode – the “OFF” mode – where all circuits are no longer powered, therefore allowing the lowest possible current consumption.

When in “OFF” mode, an action on the ON/OFF switch will turn-on the power supply of the digital core ( $V_{DD}$ ) and apply a power-on-reset condition. Alternatively, entering the “OFF” mode from the “ON” mode requires firmware action.

When in “ON” mode, an action on the ON/OFF switch will send a request to the controller that will have to be acknowledged (firmware action required) in order to enter the “OFF” state.

When placed into the “OFF” state, the 73S1210F will consume minimum current from  $V_{PC}$  and  $V_{BAT}$ ;  $V_P$  and  $V_{DD}$  will be unavailable ( $V_{DD}$  out = 0V and  $V_P$  = 0V).

When in “ON” mode, the 73S1210F will operate normally, with all the features described in this document available.  $V_P$  and  $V_{DD}$  will be available ( $V_{DD}$  out = 3.3V and  $V_P$  = 5.5V nominal).

Whenever  $V_{BUS}$  power is supplied, the circuit will be automatically in the “ON” state. The functions of the ON/OFF switch and circuitry are overridden and the 73S1210F is in the “ON” state with  $V_P$  and  $V_{DD}$  available.

Without  $V_{BUS}$  applied, the circuit is by default in the “OFF” state, and will respond only to the ON\_OFF pin. The ON\_OFF pin should be connected to an SPST switch to ground. If the circuit is OFF and the switch is closed for a debounce period of 50-100ms, the circuit will go into the “ON” state wherein all functions are operating in normal fashion. If the circuit is in the “ON” state and the ON/OFF pin is connected to ground for a period greater than the debounce period, OFF\_REQ will be asserted high and held regardless of the state of ON/OFF. The OFF\_REQ signal should be connected to one of the interrupt pins to signal the CPU core that a request to shutdown has been initiated. The firmware will acknowledge this request by setting the SCPWRDN bit in the Smart Card  $V_{CC}$  Control/Status Register ( $V_{CC}Ctl$ ) high after it has completed all shutdown activities. When SCPWRDN is set high, the circuit will deactivate the smart card interface if required and turn off all analog functions and the  $V_{DD}$  supply for the logic and companion circuits. The default state upon application of power is the “OFF” state unless power is supplied to the  $V_{BUS}$  supply. Note that at any time, the firmware may assert SCPWRDN and the

73S1210F will go into the “OFF” state (when  $V_{BUS}$  is not present). If the ON/OFF switch function is not desired and the application does not need to shut down power on VDD, the ON\_OFF input can be permanently grounded which will automatically turn on VDD when power is supplied on any of the VPC, VBAT or VBUS power supply inputs.

If power is applied to both  $V_{BAT}$  and  $V_{BUS}$ , the circuit will automatically consume power from only the  $V_{BUS}$  source. The 73S1210F will be unconditionally “ON” when  $V_{BUS}$  is applied. If the  $V_{BUS}$  source is removed, the 73S1210F will switchover to the VBAT input supply and remain in the “ON” state. The firmware should assert SCPWRDN based on no activity or  $V_{BUS}$  removal to reduce battery power consumption. When operating from  $V_{BUS}$ , and not calling for  $V_{CC}$ , the step-up converter becomes a simple switch connecting  $V_{BUS}$  to  $V_P$  in order to save power.

Note: When the ON\_OFF switch function is not needed, i.e. when the 73S1210F must be in an always-ON state when using another supply than VBUS ( $V_{PC}$  or  $V_{BAT}$ ), some external discrete components are needed.

### 1.7.4 Power Control Modes

The 73S1210F contains circuitry to disable portions of the device and place it into a lower power standby mode or power down the 73S1210F into its “OFF” mode. The standby mode will stop the core, clock subsystem and the peripherals connected to it. This is accomplished by either shutting off the power or disabling the clock going to the block. The Miscellaneous Control registers **MISCTI0**, **MISCTI1** and the Master Clock Control register (**MCLKCTI**) provide control over the power modes. The PWRDN bit in **MISCTI0** will setup the 73S1210F for standby or “OFF” modes. Depending on the state of the ON/OFF circuitry and power applied to the VBUS input, the 73S1210F will go into either standby mode or power “OFF” mode. If system power is provided by, VBUS or the ON/OFF circuitry is in the “ON” state, the MPU core will placed into standby mode. If the VBUS input is not sourcing power and the ON/OFF circuitry is in the “OFF” state, setting the PWRDN bit will shut down the converter and VP will turn off. The power down mode should only be initiated by setting the PWRDN bit in the **MISCTI0** register and not by manipulating individual control bits in various registers. Figure 6 shows how the PWRDN bit controls the various functions that comprise power down state.

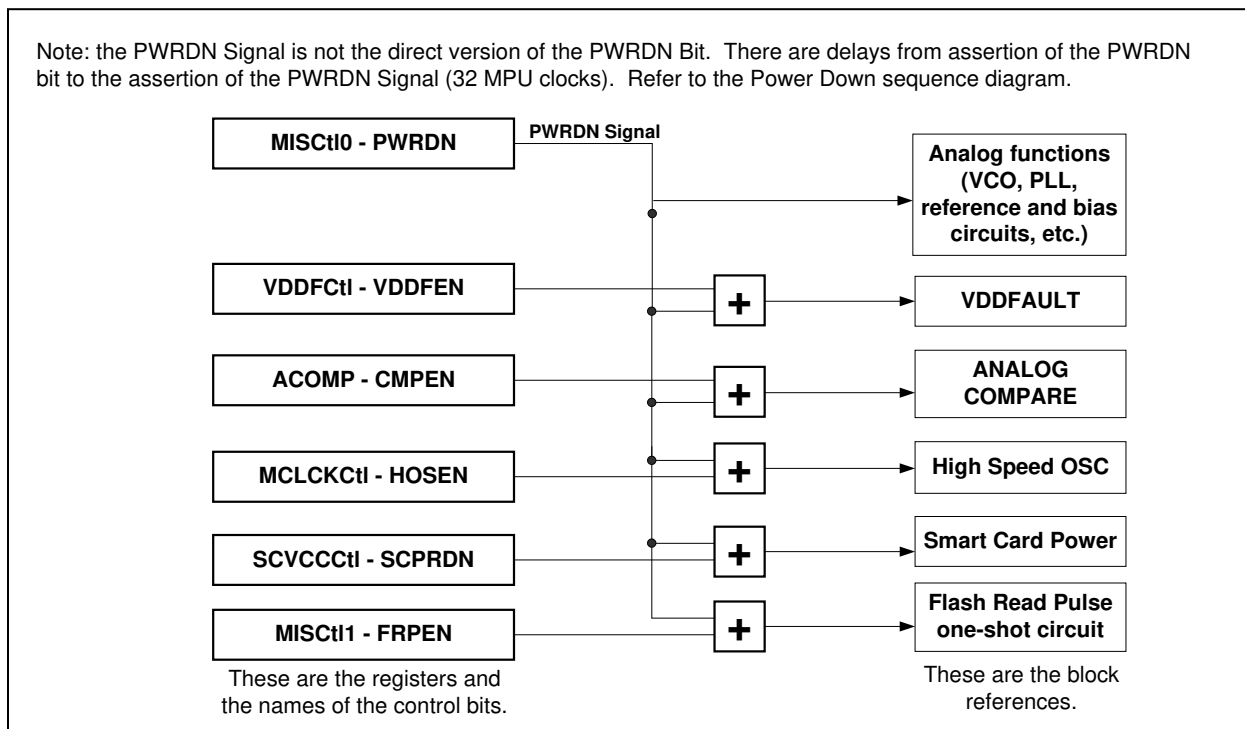
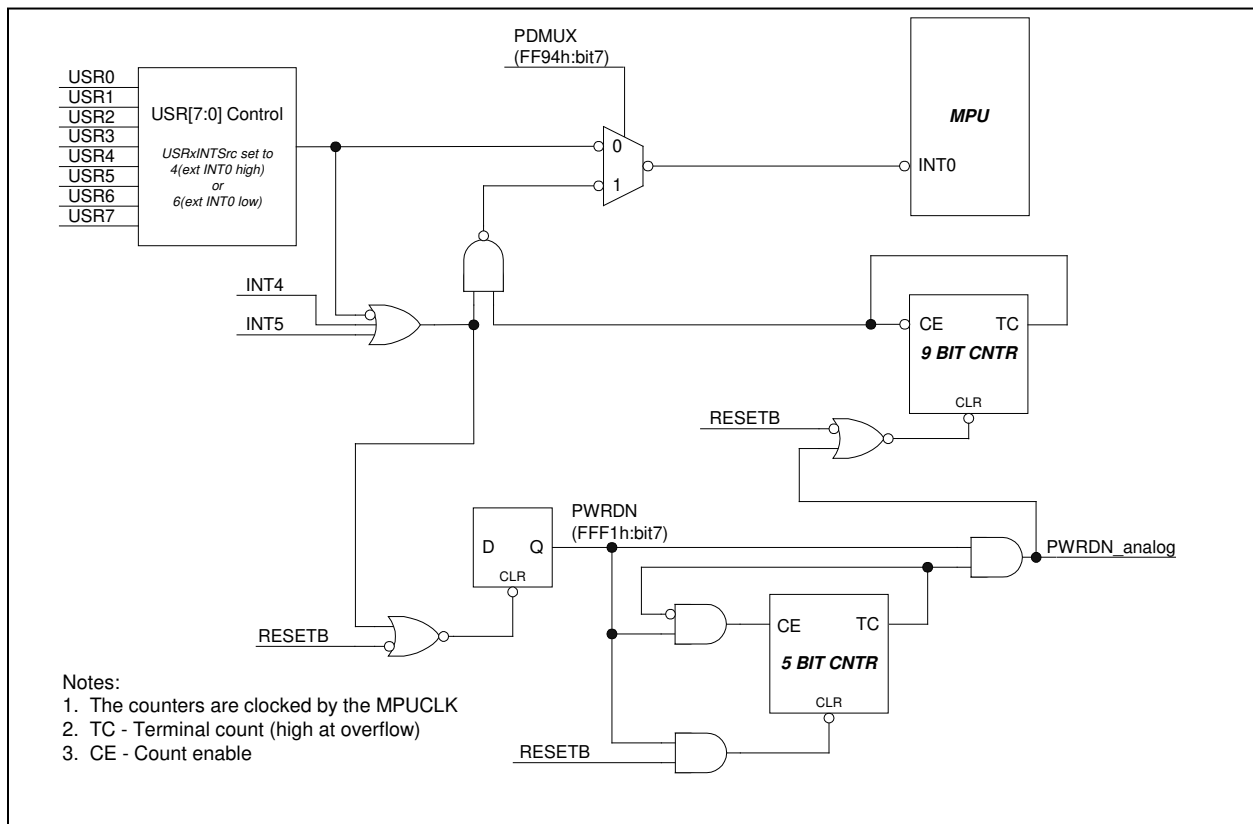
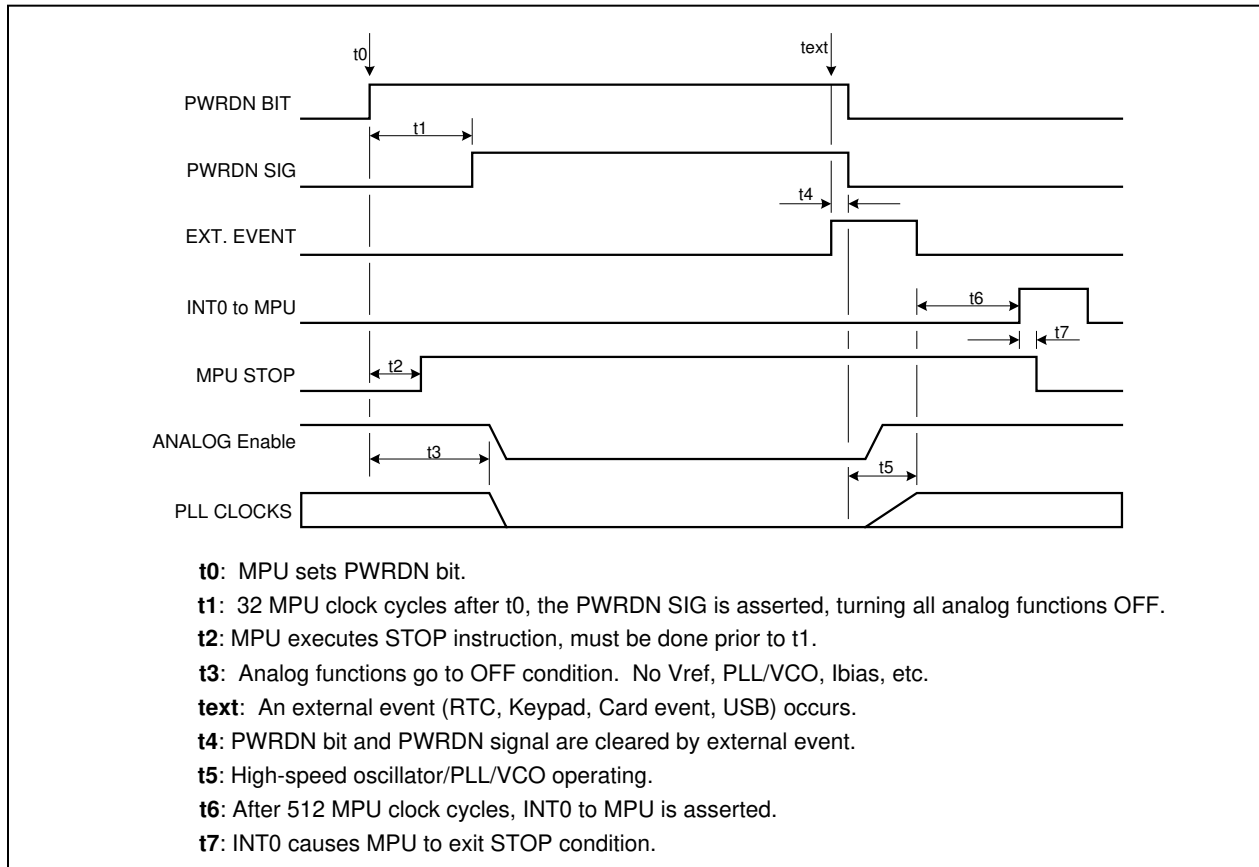


Figure 6: Power Down Control

When the PWRDN bit is set, the clock subsystem will provide a delay of 32 MPUCLK cycles to allow the program to set the STOP bit in the PCON register. This delay will enable the program to properly halt the core before the analog circuits shut down (high speed oscillator, VCO/PLL, voltage reference and bias circuitry, etc.). The PDMUX bit in SFR INT5CtI should be set prior to setting the PWRDN bit in order to configure the wake up interrupt logic. The power down mode is de-asserted by any of the interrupts connected to external interrupts 0, 4 and 5 (external USR[0:7], smart card and Keypad). These interrupt sources are OR'ed together and routed through some delay logic into INT0 to provide this functionality. The interrupt will turn on the power to all sections that were shut off and start the clock subsystem. After the clock subsystem clocks start running, the MPUCLK begins to clock a 512 count delay counter. When the counter times out, the interrupt will then be active on INT0 and the program can resume. Figure 7 shows the detailed logic for waking up the 73S1210F from a power down state using these specific interrupt sources. Figure 8 shows the timing associated with the power down mode.



**Figure 7: Detail of Power Down Interrupt Logic**



**Figure 8: Power Down Sequencing**

**External Interrupt Control Register (INT5Ctl): 0xFF94 ← 0x00****Table 14: The INT5Ctl Register**

MSB	LSB
PDMUX	KPIEN KPINT

Bit	Symbol	Function
INT5Ctl.7	PDMUX	When set = 1, enables interrupts from Keypad (normally going to int5), Smart Card interrupts (normally going to int4), or USR(7:0) pins (int0) to cause interrupt on int0. The assertion of the interrupt to int0 is delayed by 512 MPU clocks to allow the analog circuits, including the clock system, to stabilize. This bit must be set prior to asserting the PWRDN bit in order to properly configure the interrupts that will wake up the circuit. This bit is reset = 0 when this register is read.
INT5Ctl.6	–	
INT5Ctl.5	–	
INT5Ctl.4	–	
INT5Ctl.3	–	
INT5Ctl.2	–	
INT5Ctl.1	KPIEN	Keypad interrupt enable.
INT5Ctl.0	KPINT	Keypad interrupt flag.

**Miscellaneous Control Register 0 (MISctl0): 0xFFF1 ← 0x00****Table 15: The MISctl0 Register**

MSB	LSB
PWRDN	SLPBK SSEL

Bit	Symbol	Function
MISctl0.7	PWRDN	This bit sets the circuit into a low-power condition. All analog (high-speed oscillator and VCO/PLL) functions are disabled 32 MPU clock cycles after this bit is set = 1. This allows time for the next instruction to set the STOP bit in the <a href="#">PCON</a> register to stop the CPU core. The MPU is not operative in this mode. When set, this bit overrides the individual control bits that otherwise control power consumption.
MISctl0.6	–	
MISctl0.5	–	
MISctl0.4	–	
MISctl0.3	–	
MISctl0.2	–	
MISctl0.1	SLPBK	UART loop back testing mode.
MISctl0.0	SSEL	Serial port pins select.

**Miscellaneous Control Register 1 (MISCTl1): 0xFFF2 ← 0x10****Table 16: The MISCTl1 Register**

MSB	-	-	FRPEN	FLSH66	-	-	-	-	LSB
-----	---	---	-------	--------	---	---	---	---	-----

Bit	Symbol	Function
MISCTl1.7	-	
MISCTl1.6	-	
MISCTl1.5	FRPEN	Flash Read Pulse enable (low). If FRPEN = 1, the Flash Read signal is passed through with no change. When FRPEN = 0 a one-shot circuit that shortens the Flash Read signal is enabled to save power. The Flash Read pulse will shorten to 40 or 66ns (approximate based on the setting of the FLSH66 bit) in duration, regardless of the MPU clock rate. For MPU clock frequencies greater than 10MHz, this bit should be set high.
MISCTl1.4	FLSH66	When high, creates a 66ns Flash read pulse, otherwise creates a 40ns read pulse when FRPEN is set.
MISCTl1.3	-	
MISCTl1.2	-	
MISCTl1.1	-	
MISCTl1.0	-	

**Master Clock Control Register (MCLKCtl): 0x8F ← 0x0A****Table 17: The MCLKCtl Register**

MSB	HSOEN	KBEN	SCEN	-	-	MCT.2	MCT.1	MCT.0	LSB
-----	-------	------	------	---	---	-------	-------	-------	-----

Bit	Symbol	Function
MCLKCtl.7	HSOEN*	High-speed oscillator enable. When set = 1, disables the high-speed crystal oscillator and VCO/PLL system. This bit is not changed when the PWRDN bit is set but the oscillator/VCO/PLL is disabled.
MCLKCtl.6	KBEN	1 = Disable the keypad logic clock. This bit is not changed in PWRDN mode but the function is disabled.
MCLKCtl.5	SCEN	1 = Disable the smart card logic clock. This bit is not changed in PWRDN mode but the function is disabled. Interrupt logic for card insertion/removal remains operable even with smart card clock disabled.
MCLKCtl.4	-	
MCLKCtl.3	-	
MCLKCtl.2	MCT.2	This value determines the ratio of the VCO frequency (MCLK) to the high-speed crystal oscillator frequency such that: $MCLK = (MCount * 2 + 4) * Fxtal$ . The default value is $MCount = 2h$ such that $MCLK = (2 * 2 + 4) * 12.00MHz = 96MHz$ .
MCLKCtl.1	MCT.1	
MCLKCtl.0	MCT.0	

\*Note: The HSOEN bit should never be set under normal circumstances. Power down control should only be initiated via use of the PWRDN bit in [MISCTl0](#).

**Power Control Register 0 (PCON): 0x87 ← 0x00**

The SMOD bit used for the baud rate generator is set up via this register.

**Table 18: The PCON Register**

MSB							LSB
SMOD	–	–	–	GF1	GF0	STOP	IDLE

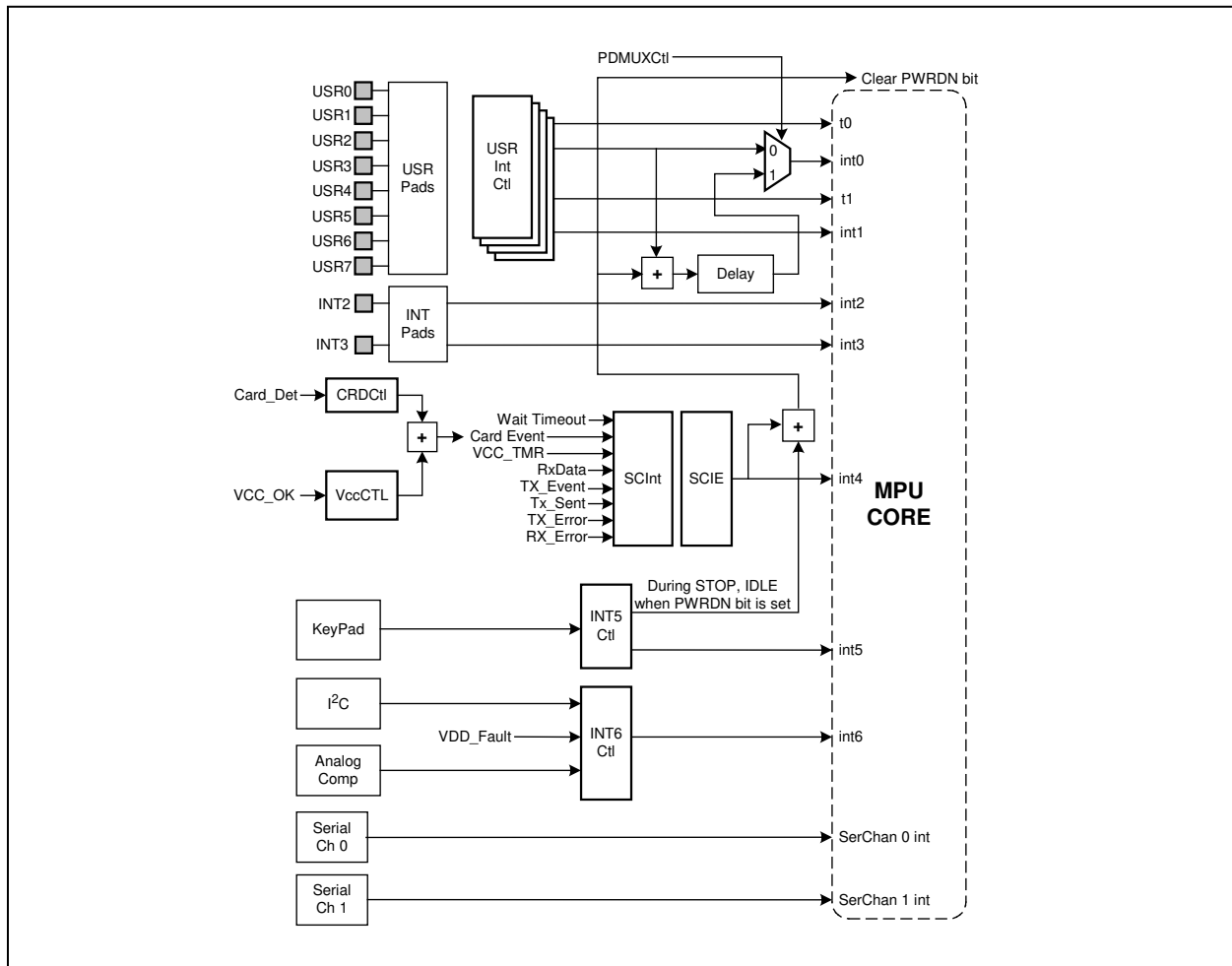
Bit	Symbol	Function
PCON.7	SMOD	If SMOD = 1, the baud rate is doubled.
PCON.6	–	
PCON.5	–	
PCON.4	–	
PCON.3	GF1	General purpose flag 1.
PCON.2	GF0	General purpose flag 1.
PCON.1	STOP	Sets CPU to Stop mode.
PCON.0	IDLE	Sets CPU to Idle mode.



### 1.7.5 Interrupts

The 80515 core provides 10 interrupt sources with four priority levels. Each source has its own request flag(s) located in a special function register (**TCON**, **IRCON**, and **SCON**). Each interrupt requested by the corresponding flag can be individually enabled or disabled by the enable bits in SFRs **IEN0**, **IEN1**, and **IEN2**. Some of the 10 sources are multiplexed in order to expand the number of interrupt sources. These are described in more detail in the respective sections.

External interrupts are the interrupts external to the 80515 core, i.e. signals that originate in other parts of the 73S1210F, for example the USR I/O, smart card interface, analog comparators, etc. The external interrupt configuration is shown in Figure 9.



**Figure 9: External Interrupt Configuration**

### 1.7.5.1 Interrupt Overview

When an interrupt occurs, the MPU will vector to the predetermined address as shown in [Table 32](#). Once the interrupt service has begun, it can only be interrupted by a higher priority interrupt. The interrupt service is terminated by a return from the RETI instruction. When a RETI is performed, the processor will return to the instruction that would have been next when the interrupt occurred.

When the interrupt condition occurs, the processor will also indicate this by setting a flag bit. This bit is set regardless of whether the interrupt is enabled or disabled. Each interrupt flag is sampled once per machine cycle, then samples are polled by the hardware. If the sample indicates a pending interrupt when the interrupt is enabled, then the interrupt request flag is set. On the next instruction cycle, the interrupt will be acknowledged by hardware forcing an LCALL to the appropriate vector address.

Interrupt response will require a varying amount of time depending on the state of the MPU when the interrupt occurs. If the MPU is performing an interrupt service with equal or greater priority, the new interrupt will not be invoked. In other cases, the response time depends on the current instruction. The fastest possible response to an interrupt is 7 machine cycles. This includes one machine cycle for detecting the interrupt and six cycles to perform the LCALL.

### 1.7.5.2 Special Function Registers for Interrupts

**Interrupt Enable 0 Register (IEN0): 0xA8 ← 0x00**

**Table 19: The IEN0 Register**

MSB	EAL	WDT	–	ES0	ET1	EX1	ET0	EX0	LSB
-----	-----	-----	---	-----	-----	-----	-----	-----	-----

Bit	Symbol	Function
IEN0.7	EAL	EAL = 0 – disable all interrupts.
IEN0.6	WDT	Not used for interrupt control.
IEN0.5	–	
IEN0.4	ES0	ES0 = 0 – disable serial channel 0 interrupt.
IEN0.3	ET1	ET1 = 0 – disable timer 1 overflow interrupt.
IEN0.2	EX1	EX1 = 0 – disable external interrupt 1.
IEN0.1	ET0	ET0 = 0 – disable timer 0 overflow interrupt.
IEN0.0	EX0	EX0 = 0 – disable external interrupt 0.

**Interrupt Enable 1 Register (IEN1): 0xB8 ← 0x00****Table 20: The IEN1 Register**

MSB	LSB
–	–

Bit	Symbol	Function
IEN1.7	–	
IEN1.6	SWDT	Not used for interrupt control.
IEN1.5	EX6	EX6 = 0 – disable external interrupt 6.
IEN1.4	EX5	EX5 = 0 – disable external interrupt 5.
IEN1.3	EX4	EX4 = 0 – disable external interrupt 4.
IEN1.2	EX3	EX3 = 0 – disable external interrupt 3.
IEN1.1	EX2	EX2 = 0 – disable external interrupt 2.
IEN1.0	–	

**Interrupt Enable 2 Register (IEN2): 0x9A ← 0x00****Table 21: The IEN2 Register**

MSB	LSB
–	ES1

Bit	Symbol	Function
IEN2.0	ES1	ES1 = 0 – disable serial channel interrupt.

**Timer/Counter Control Register (TCON): 0x88 ← 0x00****Table 22: The TCON Register**

MSB	LSB						
TF1	TR1	TF0	TR0	IE1	IT1	IE0	IT0

Bit	Symbol	Function
TCON.7	TF1	Timer 1 overflow flag.
TCON.6	TR1	Not used for interrupt control.
TCON.5	TF0	Timer 0 overflow flag.
TCON.4	TR0	Not used for interrupt control.
TCON.3	IE1	Interrupt 1 edge flag is set by hardware when the falling edge on external interrupt int1 is observed. Cleared when an interrupt is processed.
TCON.2	IT1	Interrupt 1 type control bit. 1 selects falling edge and 0 selects low level for input pin to cause an interrupt.
TCON.1	IE0	Interrupt 0 edge flag is set by hardware when the falling edge on external interrupt int0 is observed. Cleared when an interrupt is processed.
TCON.0	IT0	Interrupt 0 type control bit. 1 selects falling edge and 0 sets low level for input pin to cause interrupt.

**Timer/Interrupt 2 Control Register (T2CON): 0xC8 ← 0x00****Table 23: The T2CON Register**

MSB	LSB						
–	I3FR	I2FR	–	–	–	–	–

Bit	Symbol	Function
T2CON.7	–	
T2CON.6	I3FR	External interrupt 3 failing/rising edge flag. I3FR = 0 external interrupt 3 negative transition active. I3FR = 1 external interrupt 3 positive transition active.
T2CON.5	I2FR	External interrupt 3 failing/rising edge flag. I2FR = 0 external interrupt 3 negative transition active. I2FR = 1 external interrupt 3 positive transition active.
T2CON.4	–	
T2CON.3	–	
T2CON.2	–	
T2CON.1	–	
T2CON.0	–	

**Interrupt Request Register (IRCON): 0xC0 ← 0x00****Table 24: The IRCON Register**

MSB						LSB	
–	–	EX6	IEX5	IEX4	IEX3	IEX2	–

Bit	Symbol	Function
IRCON.7	–	
IRCON.6	–	
IRCON.5	IEX6	External interrupt 6 flag.
IRCON.4	IEX5	External interrupt 5 flag.
IRCON.3	IEX4	External interrupt 4 flag.
IRCON.2	IEX3	External interrupt 3 flag.
IRCON.1	IEX2	External interrupt 2 flag.
IRCON.0	–	

**1.7.5.3 External Interrupts**

The external interrupts (external to the CPU core) are connected as shown in Table 25. Interrupts with multiple sources are OR'ed together and individual interrupt source control is provided in XRAM SFRs to mask the individual interrupt sources and provide the corresponding interrupt flags. Multifunction USR [7:0] pins control Interrupts 0 and 1. Dedicated external interrupt pins INT2 and INT3 control interrupts 2 and 3. The polarity of interrupts 2 and 3 is programmable in the MPU. Interrupts 4, 5 and 6 have multiple peripheral sources and are multiplexed to one of these three interrupts. The peripheral functions will be described in subsequent sections. Generic 80515 MPU literature states that interrupts 4 through 6 are defined as rising edge sensitive. Thus, the hardware signals attached to interrupts 4, 5 and 6 are converted to rising edge level by the hardware.

SFR (special function register) enable bits must be set to permit any of these interrupts to occur. Likewise, each interrupt has its own flag bit that is set by the interrupt hardware and is reset automatically by the MPU interrupt handler.

**Table 25: External MPU Interrupts**

External Interrupt	Connection	Polarity	Flag Reset
0	USR I/O High Priority	see <a href="#">USRIntCtlx</a>	Automatic
1	USR I/O Low Priority	see <a href="#">USRIntCtlx</a>	Automatic
2	External Interrupt Pin INT2	Edge selectable	Automatic
3	External Interrupt Pin INT3	Edge selectable	Automatic
4	Smart Card Interrupts	N/A	Automatic
5	Keypad	N/A	Automatic
6	I <sup>2</sup> C, V <sub>DD</sub> _Fault, Analog Comp	N/A	Automatic

Note: Interrupts 4, 5 and 6 have multiple interrupt sources and the flag bits are cleared upon reading of the corresponding register. To prevent any interrupts from being ignored, the register containing multiple interrupt flags should be stored temporary to allow each interrupt flag to be tested separately to see which interrupt(s) is/are pending.

**Table 26: Control Bits for External Interrupts**

Enable Bit	Description	Flag Bit	Description
EX0	Enable external interrupt 0	IE0	External interrupt 0 flag
EX1	Enable external interrupt 1	IE1	External interrupt 1 flag
EX2	Enable external interrupt 2	IEX2	External interrupt 2 flag
EX3	Enable external interrupt 3	IEX3	External interrupt 3 flag
EX4	Enable external interrupt 4	IEX4	External interrupt 4 flag
EX5	Enable external interrupt 5	IEX5	External interrupt 5 flag
EX6	Enable external interrupt 6	IEX6	External interrupt 6 flag

**1.7.5.4 Power Down Interrupt Logic**

The 73S1210F contains special interrupt logic to allow INT0 to wake up the CPU from a power down (CPU STOP) state. See the [Power Control Modes](#) section for details.

**1.7.5.5 Interrupt Priority Level Structure**

All interrupt sources are combined in groups, as shown in Table 27.

**Table 27: Priority Level Groups**

Group			
0	External interrupt 0	Serial channel 1 interrupt	
1	Timer 0 interrupt	–	External interrupt 2
2	External interrupt 1	–	External interrupt 3
3	Timer 1 interrupt	–	External interrupt 4
4	Serial channel 0 interrupt	–	External interrupt 5
5	–	–	External interrupt 6

Each group of interrupt sources can be programmed individually to one of four priority levels by setting or clearing one bit in the special function register IP0 and one in IP1. If requests of the same priority level are received simultaneously, an internal polling sequence as per [Table 31](#) determines which request is serviced first.

IEN enable bits must be set to permit any of these interrupts to occur. Likewise, each interrupt has its own flag bit that is set by the interrupt hardware and is reset automatically by the MPU interrupt handler.

**Interrupt Priority 0 Register (IP0): 0xA9 ← 0x00****Table 28: The IP0 Register**

MSB								LSB	
–	WDTS	IP0.5	IP0.4	IP0.3	IP0.2	IP0.1	IP0.0		

Note: WDTS is not used for interrupt controls.

**Interrupt Priority 1 Register (IP1): 0xB9 ← 0x00****Table 29: The IP1 Register**

MSB								LSB
	-	-	IP1.5	IP1.4	IP1.3	IP1.2	IP1.1	IP1.0

**Table 30: Priority Levels**

IP1.x	IP0.x	Priority Level
0	0	Level0 (lowest)
0	1	Level1
1	0	Level2
1	1	Level3 (highest)

**Table 31: Interrupt Polling Sequence**

External interrupt 0	Polling sequence ↓
Serial channel 1 interrupt	
Timer 0 interrupt	
External interrupt 2	
External interrupt 1	
External interrupt 3	
Timer 1 interrupt	
Serial channel 0 interrupt	
External interrupt 4	
External interrupt 5	
External interrupt 6	

**1.7.5.6 Interrupt Sources and Vectors**

Table 32 shows the interrupts with their associated flags and vector addresses.

**Table 32: Interrupt Vectors**

Interrupt Request Flag	Description	Interrupt Vector Address
N/A	Chip Reset	0x0000
IE0	External interrupt 0	0x0003
TF0	Timer 0 interrupt	0x000B
IE1	External interrupt 1	0x0013
TF1	Timer 1 interrupt	0x001B
RI0/TI0	Serial channel 0 interrupt	0x0023
RI1/TI1	Serial channel 1 interrupt	0x0083
IEX2	External interrupt 2	0x004B
IEX3	External interrupt 3	0x0053
IEX4	External interrupt 4	0x005B
IEX5	External interrupt 5	0x0063
IEX6	External interrupt 6	0x006B

### 1.7.6 UART

The 80515 core of the 73S1210F includes two separate UARTs that can be programmed to communicate with a host. The 73S1210F can only connect one UART at a time since there is only one set of TX and Rx pins. The [MISCT10](#) register is used to select which UART is connected to the TX and RX pins. Each UART has a different set of operating modes that the user can select according to their needs. The UART is a dedicated 2-wire serial interface, which can communicate with an external host processor at up to 115,200 bits/s. The TX and RX pins operate at the  $V_{DD}$  supply voltage levels and should never exceed 3.6V. The operation of each pin is as follows:

**RX:** Serial input data is applied at this pin. Conforming to RS-232 standard, the bytes are input LSB first. The voltage applied at RX must not exceed 3.6V.

**TX:** This pin is used to output the serial data. The bytes are output LSB first.

The 73S1210F has several UART-related read/write registers. All UART transfers are programmable for parity enable, parity select, 2 stop bits/1 stop bit and XON/XOFF options for variable communication baud rates from 300 to 115200 bps. [Table 33](#) shows the selectable UART operation modes and [Table 34](#) shows how the baud rates are calculated.

**Table 33: UART Modes**

	UART 0	UART 1
<b>Mode 0</b>	N/A	Start bit, 8 data bits, parity, stop bit, variable baud rate (internal baud rate generator).
<b>Mode 1</b>	Start bit, 8 data bits, stop bit, variable baud rate (internal baud rate generator or timer 1).	Start bit, 8 data bits, stop bit, variable baud rate (internal baud rate generator).
<b>Mode 2</b>	Start bit, 8 data bits, parity, stop bit, fixed baud rate 1/32 or 1/64 of $f_{CKMPU}$ .	N/A
<b>Mode 3</b>	Start bit, 8 data bits, parity, stop bit, variable baud rate (internal baud rate generator or timer 1).	N/A

Note: Parity of serial data is available through the P flag of the accumulator. Seven-bit serial modes with parity, such as those used by the FLAG protocol, can be simulated by setting and reading bit 7 of 8-bit output data. Seven-bit serial modes without parity can be simulated by setting bit 7 to a constant 1. 8-bit serial modes with parity can be simulated by setting and reading the 9th bit, using the control bits S0CON3 and S1CON3 in the S0CON and S1CON SFRs.

**Table 34: Baud Rate Generation**

	Using Timer 1	Using Internal Baud Rate Generator
<b>Serial Interface 0</b>	$2^{smod} * f_{CKMPU} / (384 * (256 - TH1))$	$2^{smod} * f_{CKMPU} / (64 * (2^{10} - S0REL))$
<b>Serial Interface 1</b>	N/A	$f_{CKMPU} / (32 * (2^{10} - S1REL))$

Note: S0REL (9:0) and S1REL (9:0) are 10-bit values derived by combining bits from the respective timer reload registers SxRELH (bits 1:0) and SxRELL (bits 7:0). TH1 is the high byte of timer 1. The SMOD bit is located in the [PCON](#) SFR.



**Power Control Register 0 (PCON): 0x87 ← 0x00**

The SMOD bit used for the baud rate generator is set up via this register.

**Table 35: The PCON Register**

MSB							LSB
SMOD	–	–	–	GF1	GF0	STOP	IDLE

Bit	Symbol	Function
PCON.7	SMOD	If SM0D = 1, the baud rate is doubled.
PCON.6	–	
PCON.5	–	
PCON.4	–	
PCON.3	GF1	General purpose flag 1.
PCON.2	GF0	General purpose flag 1.
PCON.1	STOP	Sets CPU to Stop mode.
PCON.0	IDLE	Sets CPU to Idle mode.

**Baud Rate Control Register 0 (BRCON): 0xD8 ← 0x00**

The BSEL bit used to enable the baud rate generator is set up via this register.

**Table 36: The BRCON Register**

MSB							LSB
BSEL	–	–	–	–	–	–	–

Bit	Symbol	Function
BRCON.7	BSEL	If BSEL = 0, the baud rate is derived using timer 1. If BSEL = 1 the baud rate generator circuit is used.
BRCON.6	–	
BRCON.5	–	
BRCON.4	–	
BRCON.3	–	
BRCON.2	–	
BRCON.1	–	
BRCON.0	–	

**Miscellaneous Control Register 0 (MISCTI0): 0xFFF1 ← 0x00**

Transmit and receive (TX and RX) pin selection and loop back test configuration are setup via this register.

**Table 37: The MISCTI0 Register**

MSB								LSB	
PWRDN	–	–	–	–	–	–	SLPBK	SSEL	

Bit	Symbol	Function															
MISCTI0.7	PWRDN	This bit places the 73S1210F into a power down state.															
MISCTI0.6	–																
MISCTI0.5	–																
MISCTI0.4	–																
MISCTI0.3	–																
MISCTI0.2	–																
MISCTI0.1	SLPBK	1 = UART loop back testing mode. The pins TXD and RXD are to be connected together externally (with SLPBK =1) and therefore: <table border="1" style="margin-left: 40px;"> <thead> <tr> <th>SLPBK</th> <th>SSEL</th> <th>Mode</th> </tr> </thead> <tbody> <tr> <td>0</td> <td>0</td> <td>normal using Serial_0</td> </tr> <tr> <td>0</td> <td>1</td> <td>normal using Serial_1</td> </tr> <tr> <td>1</td> <td>0</td> <td>Serial_0 TX feeds Serial_1 RX</td> </tr> <tr> <td>1</td> <td>1</td> <td>Serial_1 TX feeds Serial_0 RX</td> </tr> </tbody> </table>	SLPBK	SSEL	Mode	0	0	normal using Serial_0	0	1	normal using Serial_1	1	0	Serial_0 TX feeds Serial_1 RX	1	1	Serial_1 TX feeds Serial_0 RX
SLPBK	SSEL	Mode															
0	0	normal using Serial_0															
0	1	normal using Serial_1															
1	0	Serial_0 TX feeds Serial_1 RX															
1	1	Serial_1 TX feeds Serial_0 RX															
MISCTI0.0	SSEL	Selects either Serial_1 if set =1 or Serial_0 if set = 0 to be connected to RXD and TXD pins.															

**1.7.6.1 Serial Interface 0**

The Serial Interface 0 can operate in 4 modes:

- **Mode 0**

Pin RX serves as input and output. TX outputs the shift clock. 8 bits are transmitted with LSB first. The baud rate is fixed at 1/12 of the crystal frequency. Reception is initialized in Mode 0 by setting the flags in [SOCON](#) as follows: RI0 = 0 and REN0 = 1. In other modes, a start bit when REN0 = 1 starts receiving serial data.

- **Mode 1**

Pin RX serves as input, and TX serves as serial output. No external shift clock is used, 10 bits are transmitted: a start bit (always 0), 8 data bits (LSB first), and a stop bit (always 1). On receive, a start bit synchronizes the transmission, 8 data bits are available by reading S0BUF, and stop bit sets the flag RB80 in the Special Function Register [SOCON](#). In mode 1 either internal baud rate generator or timer 1 can be use to specify baud rate.

- **Mode 2**

This mode is similar to Mode 1, with two differences. The baud rate is fixed at 1/32 or 1/64 of oscillator frequency and 11 bits are transmitted or received: a start bit (0), 8 data bits (LSB first), a programmable 9th bit, and a stop bit (1). The 9th bit can be used to control the parity of the serial interface: at transmission, bit TB80 in [SOCON](#) is output as the 9th bit, and at receive, the 9th bit affects RB80 in Special Function Register [SOCON](#).

- **Mode 3**

The only difference between Mode 2 and Mode 3 is that in Mode 3 either internal baud rate generator or timer 1 can be use to specify baud rate.

The **S0BUF** register is used to read/write data to/from the serial 0 interface.

### Serial Interface 0 Control Register (S0CON): 0x9B ← 0x00

Transmit and receive data are transferred via this register.

**Table 38: The S0CON Register**

MSB								LSB
SM0	SM1	SM20	REN0	TB80	RB80	TI0	RI0	
Bit	Symbol	Function						
S0CON.7	SM0	These two bits set the UART0 mode:						
		<b>Mode</b>	<b>Description</b>	<b>SM0</b>	<b>SM1</b>			
		0	N/A	0	0			
S0CON.6	SM1	1	8-bit UART	0	1			
		2	9-bit UART	1	0			
		3	9-bit UART	1	1			
S0CON.5	SM20	Enables the inter-processor communication feature.						
S0CON.4	REN0	If set, enables serial reception. Cleared by software to disable reception.						
S0CON.3	TB80	The 9th transmitted data bit in Modes 2 and 3. Set or cleared by the MPU, depending on the function it performs (parity check, multiprocessor communication etc.).						
S0CON.2	RB80	In Modes 2 and 3 it is the 9th data bit received. In Mode 1, if SM20 is 0, RB80 is the stop bit. In Mode 0 this bit is not used. Must be cleared by software.						
S0CON.1	TI0	Transmit interrupt flag, set by hardware after completion of a serial transfer. Must be cleared by software.						
S0CON.0	RI0	Receive interrupt flag, set by hardware after completion of a serial reception. Must be cleared by software.						

### 1.7.6.2 Serial Interface 1

The Serial Interface 1 can operate in 2 modes:

- **Mode A**

This mode is similar to Mode 2 and 3 of Serial interface 0, 11 bits are transmitted or received: a start bit (0), 8 data bits (LSB first), a programmable 9th bit, and a stop bit (1). The 9th bit can be used to control the parity of the serial interface: at transmission, bit TB81 in S1CON is outputted as the 9th bit, and at receive, the 9th bit affects RB81 in Special Function Register S1CON. The only difference between Mode 3 and A is that in Mode A only the internal baud rate generator can be used to specify baud rate.

- **Mode B**

This mode is similar to Mode 1 of Serial interface 0. Pin RX serves as input, and TX serves as serial output. No external shift clock is used, 10 bits are transmitted: a start bit (always 0), 8 data bits (LSB first), and a stop bit (always 1). On receive, a start bit synchronizes the transmission, 8 data bits are available by reading S1BUF, and stop bit sets the flag RB81 in the Special Function Register S1CON. In mode 1, the internal baud rate generator is used to specify the baud rate.

The S1BUF register is used to read/write data to/from the serial 1 interface.

#### Serial Interface Control Register (S1CON): 0x9B ← 0x00

The function of the serial port depends on the setting of the Serial Port Control Register S1CON.

**Table 39: The S1CON Register**

MSB								LSB	
SM	–	SM21	REN1	TB81	RB81	TI1	RI1		
Bit	Symbol	Function							
S1CON.7	SM	Sets the UART operation mode.							
		<b>SM</b>	<b>Mode</b>	<b>Description</b>	<b>Baud Rate</b>				
		0	A	9-bit UART	variable				
		1	B	8-bit UART	variable				
S1CON.6	–								
S1CON.5	SM21	Enables the inter-processor communication feature.							
S1CON.4	REN1	If set, enables serial reception. Cleared by software to disable reception.							
S1CON.3	TB81	The 9th transmitted data bit in Mode A. Set or cleared by the MPU, depending on the function it performs (parity check, multiprocessor communication, etc.).							
S1CON.2	RB81	In Mode B, if sm21 is 0, rb81 is the stop bit. Must be cleared by software.							
S1CON.1	TI1	Transmit interrupt flag, set by hardware after completion of a serial transfer. Must be cleared by software.							
S1CON.0	RI1	Receive interrupt flag, set by hardware after completion of a serial reception. Must be cleared by software.							

**Multiprocessor operation mode:** The feature of receiving 9 bits in Modes 2 and 3 of Serial Interface 0 or in Mode A of Serial Interface 1 can be used for multiprocessor communication. In this case, the slave processors have bit SM20 in S0CON or SM21 in S1CON set to 1. When the master processor outputs slave's address, it sets the 9th bit to 1, causing a serial port receive interrupt in all the slaves. The slave processors compare the received byte with their network address. If there is a match, the addressed slave will clear SM20 or SM21 and receive the rest of the message, while other slaves will leave the SM20 or SM21 bit unaffected and ignore this message. After addressing the slave, the host will output the rest of the message with the 9th bit set to 0, so no serial port receive interrupt will be generated in unselected slaves.

### 1.7.7 Timers and Counters

The 80515 has two 16-bit timer/counter registers: Timer 0 and Timer 1. These registers can be configured for counter or timer operations.

In timer mode, the register is incremented every machine cycle, meaning that it counts up after every 12 periods of the MPU clock signal.

In counter mode, the register is incremented when the falling edge is observed at the corresponding input signal T0 or T1 (T0 and T1 are the timer gating inputs derived from USR[0:7] pins, see the [User \(USR\) Ports](#) section). Since it takes 2 machine cycles to recognize a 1-to-0 event, the maximum input count rate is 1/2 of the oscillator frequency. There are no restrictions on the duty cycle, however to ensure proper recognition of 0 or 1 state, an input should be stable for at least 1 machine cycle.

Four operating modes can be selected for Timer 0 and Timer 1. Two Special Function Registers (TMOD and TCON) are used to select the appropriate mode.

The Timer 0 load registers are designated as TL0 and TH0 and the Timer 1 load registers are designated as TL1 and TH1.

**Timer/Counter Mode Control Register (TMOD): 0x89 ← 0x00**

**Table 40: The TMOD Register**

MSB				LSB			
GATE	C/T	M1	M0	GATE	C/T	M1	M0
Timer 1				Timer 0			

Bits TR1 and TR0 in the [TCON register](#) start their associated timers when set.

Bit	Symbol	Function
TMOD.7 TMOD.3	Gate	If set, enables external gate control (USR pin(s) connected to T0 or T1 for Counter 0 or 1, respectively). When T0 or T1 is high, and TRx bit is set (see the <a href="#">TCON register</a> ), a counter is incremented every falling edge on T0 or T1 input pin. If not set, the TRx bit controls the corresponding timer.
TMOD.6 TMOD.2	C/T	Selects Timer or Counter operation. When set to 1, the counter operation is performed based on the falling edge of T0 or T1. When cleared to 0, the corresponding register will function as a timer.
TMOD.5 TMOD.1	M1	Selects the mode for Timer/Counter 0 or Timer/Counter 1, as shown in the TMOD description.
TMOD.4 TMOD.0	M0	Selects the mode for Timer/Counter 0 or Timer/Counter 1, as shown in the TMOD description.

**Table 41: Timers/Counters Mode Description**

M1	M0	Mode	Function
0	0	Mode 0	13-bit Counter/Timer.
0	1	Mode 1	16-bit Counter/Timer.
1	0	Mode 2	8-bit auto-reload Counter/Timer.
1	1	Mode 3	If Timer 1 M1 and M0 bits are set to '1', Timer 1 stops. If Timer 0 M1 and M0 bits are set to '1', Timer 0 acts as two independent 8-bit Timer/Counters.

**Mode 0**

Putting either timer/counter into mode 0 configures it as an 8-bit timer/counter with a divide-by-32 prescaler. In this mode, the timer register is configured as a 13-bit register. As the count rolls over from all 1's to all 0's, it sets the timer overflow flag TF0. The overflow flag TF0 then can be used to request an interrupt. The counted input is enabled to the timer when TRx = 1 and either GATE = 0 or TX = 1 (setting GATE = 1 allows the timer to be controlled by external input TX, to facilitate pulse width measurements). TRx are control bits in the special function register TCON; GATE is in TMOD. The 13-bit register consists of all 8 bits of TH1 and the lower 5 bits of TL0. The upper 3 bits of TL0 are indeterminate and should be ignored. Setting the run flag (TRx) does not clear the registers. Mode 0 operation is the same for timer 0 as for timer 1.

**Mode 1**

Mode 1 is the same as mode 0, except that the timer register is run with all 16 bits.

**Mode 2**

Mode 2 configures the timer register as an 8-bit counter (TLx) with automatic reload. The overflow from TLx not only sets TFx, but also reloads TLx with the contents of THx, which is preset by software. The reload leaves THx unchanged.

**Mode 3**

Mode 3 has different effects on timer 0 and timer 1. Timer 1 in mode 3 simply holds its count. The effect is the same as setting TR1 = 0. Timer 0 in mode 3 establishes TL0 and TH0 as two separate counters. TL0 uses the timer 0 control bits: C/T, GATE, TR0, INT0, and TF0. TH0 is locked into a timer function (counting machine cycles) and takes over the use of TR1 and TF1 from timer 1. Thus, TH0 now controls the "timer 1" interrupt. Mode 3 is provided for applications requiring an extra 8-bit timer or counter. When timer 0 is in mode 3, timer 1 can be turned on and off by switching it out of and into its own mode 3, or can still be used by the serial channel as a baud rate generator, or in fact, in any application not requiring an interrupt from timer 1 itself.

**Timer/Counter Control Register (TCON): 0x88 ← 0x00****Table 42: The TCON Register**

MSB				LSB			
TF1	TR1	TF0	TR0	IE1	IT1	IE0	IT0
Bit	Symbol	Function					
TCON.7	TF1	Timer 1 overflow flag.					
TCON.6	TR1	Not used for interrupt control.					
TCON.5	TF0	Timer 0 overflow flag.					
TCON.4	TR0	Not used for interrupt control.					
TCON.3	IE1	Interrupt 1 edge flag is set by hardware when the falling edge on external interrupt int1 is observed. Cleared when an interrupt is processed.					
TCON.2	IT1	Interrupt 1 type control bit. 1 selects falling edge and 0 selects low level for input pin to cause an interrupt.					
TCON.1	IE0	Interrupt 0 edge flag is set by hardware when the falling edge on external interrupt int0 is observed. Cleared when an interrupt is processed.					
TCON.0	IT0	Interrupt 0 type control bit. 1 selects falling edge and 0 sets low level for input pin to cause interrupt.					

### 1.7.8 WD Timer (Software Watchdog Timer)

The software watchdog timer is a 16-bit counter that is incremented once every 24 or 384 clock cycles. After a reset, the watchdog timer is disabled and all registers are set to zero. The watchdog consists of a 16-bit counter (WDT), a reload register (WDTREL), prescalers (by 2 and by 16), and control logic. Once the watchdog starts, it cannot be stopped unless the internal reset signal becomes active.

**WD Timer Start Procedure:** The WDT is started by setting the SWDT flag. When the WDT register enters the state 0x7CFF, an asynchronous WDTS signal will become active. The signal WDTS sets bit 6 in the IP0 register and requests a reset state. WDTS is cleared either by the reset signal or by changing the state of the WDT timer.

**Refreshing the WD Timer:** The watchdog timer must be refreshed regularly to prevent the reset request signal from becoming active. This requirement imposes an obligation on the programmer to issue two instructions. The first instruction sets WDT and the second instruction sets SWDT. The maximum delay allowed between setting WDT and SWDT is 12 clock cycles. If this period has expired and SWDT has not been set, WDT is automatically reset, otherwise the watchdog timer is reloaded with the content of the WDTREL register and WDT is automatically reset.

**Interrupt Enable 0 Register (IEN0): 0xA8 ← 0x00**

**Table 43: The IEN0 Register**

MSB								LSB
	EAL	WDT	ET2	ES0	ET1	EX1	ET0	EX0
Bit	Symbol	Function						
IEN0.7	EAL	EAL = 0 – disable all interrupts.						
IEN0.6	WDT	Watchdog timer refresh flag. Set to initiate a refresh of the watchdog timer. Must be set directly before SWDT is set to prevent an unintentional refresh of the watchdog timer. WDT is reset by hardware 12 clock cycles after it has been set.						
IEN0.5	–							
IEN0.4	ES0	ES0 = 0 – disable serial channel 0 interrupt.						
IEN0.3	ET1	ET1 = 0 – disable timer 1 overflow interrupt.						
IEN0.2	EX1	EX1 = 0 – disable external interrupt 1.						
IEN0.1	ET0	ET0 = 0 – disable timer 0 overflow interrupt.						
IEN0.0	EX0	EX0 = 0 – disable external interrupt 0.						

**Interrupt Enable 1 Register (IEN1): 0xB8 ← 0x00****Table 44: The IEN1 Register**

MSB	–	SWDT	EX6	EX5	EX4	EX3	EX2	LSB	–
-----	---	------	-----	-----	-----	-----	-----	-----	---

Bit	Symbol	Function
IEN1.7	–	
IEN1.6	SWDT	Watchdog timer start/refresh flag. Set to activate/refresh the watchdog timer. When directly set after setting WDT, a watchdog timer refresh is performed. Bit SWDT is reset by the hardware 12 clock cycles after it has been set.
IEN1.5	EX6	EX6 = 0 – disable external interrupt 6.
IEN1.4	EX5	EX5 = 0 – disable external interrupt 5.
IEN1.3	EX4	EX4 = 0 – disable external interrupt 4.
IEN1.2	EX3	EX3 = 0 – disable external interrupt 3.
IEN1.1	EX2	EX2 = 0 – disable external interrupt 2.
IEN1.0	–	

**Interrupt Priority 0 Register (IP0): 0xA9 ← 0x00****Table 45: The IP0 Register**

MSB	–	WDTS	IP0.5	IP0.4	IP0.3	IP0.2	IP0.1	LSB	IP0.0
-----	---	------	-------	-------	-------	-------	-------	-----	-------

Bit	Symbol	Function
IP0.6	WDTS	Watchdog timer status flag. Set when the watchdog timer has expired. The internal reset will be generated, but this bit will not be cleared by the reset. This allows the user program to determine if the watchdog timer caused the reset to occur and respond accordingly. Can be read and cleared by software.

Note: The remaining bits in the IP0 register are not used for watchdog control.

**Watchdog Timer Reload Register (WDTREL): 0x86 ← 0x00****Table 46: The WDTREL Register**

MSB	WDPSEL	WDREL6	WDREL5	WDREL4	WDREL3	WDREL2	WDREL1	LSB	WDREL0
-----	--------	--------	--------	--------	--------	--------	--------	-----	--------

Bit	Symbol	Function
WDTREL.7	WDPSEL	Prescaler select bit. When set, the watchdog is clocked through an additional divide-by-16 prescaler.
WDTREL.6 to WDTREL.0	WDREL6-0	Seven bit reload value for the high-byte of the watchdog timer. This value is loaded to the WDT when a refresh is triggered by a consecutive setting of bits WDT and SWDT.



### 1.7.9 User (USR) Ports

The 73S1210F includes 8 pins of general purpose digital I/O (GPIO). On reset or power-up, all USR pins are inputs until they are configured for the desired direction. The pins are configured and controlled by the **USR70** and **UDIR70** SFRs. Each pin declared as USR can be configured independently as an input or output with the bits of the **UDIR70** register. Table 47 lists the direction registers and configurability associated with each group of USR pins. USR pins 0 to 7 are multiple use pins that can be used for general purpose I/O, external interrupts and timer control. Table 48 shows the configuration for a USR pin through its associated bit in its UDIR register. Values read from and written into the GPIO ports use the data registers **USR70**. Note: After reset, all USR pins are defaulted as inputs and pulled up to VDD until any write to the corresponding UDIR register is performed. This insures all USR pins are set to a known value until set by the firmware. Unused USR pins can be set for output if unused and unconnected to prevent them from floating. Alternatively, unused USR pins can be set for input and tied to ground or V<sub>DD</sub>.

**Table 47: Direction Registers and Internal Resources for DIO Pin Groups**

USR Pin Group	Type	Direction Register Name	Direction Register (SFR) Location	Data Register Name	Data Register (SFR) Location
USR_0...USR_7	Multi-use	UDIR70	0x91 [7:0]	USR70	0x90 [7:0]

**Table 48: UDIR Control Bit**

	UDIR Bit	
	0	1
USR Pin Function	output	input

Four XRAM SFR registers (USRIntTctl0, USRIntTctl1, USRIntTctl2, and USRIntTctl3) control the use of the USR [7:0] pins. Each of the USR [7:0] pins can be configured as GPIO or individually be assigned an internal resource such as an interrupt or a timer/counter control. Each of the four registers contains two 3-bit configuration words named UxIS (where x corresponds to the USR pin). The control resources selectable for the USR pins are listed in [Table 50](#) through [Table 53](#). If more than one input is connected to the same resource, the resources are combined using a logical OR.

**Table 49: Selectable Controls Using the UxIS Bits**

UxIS Value	Resource Selected for USRx Pin
0	None
1	None
2	T0 (counter0 gate/clock)
3	T1 (counter1 gate/clock)
4	Interrupt 0 rising edge/high level on USRx
5	Interrupt 1 rising edge/high level on USRx
6	Interrupt 0 falling edge/low level on USRx
7	Interrupt 1 falling edge/low level on USRx

Note: x denotes the corresponding USR pin. Interrupt edge or level control is assigned in the IT0 and IT1 bits in the TCON register.

**External Interrupt Control Register (USRIntCtl1) : 0xFF90 ← 0x00**

**Table 50: The USRIntCtl1 Register**

MSB								LSB
–	U1IS.6	U1IS.5	U1IS.4	–	U0IS.2	U0IS.1	U0IS.0	

**External Interrupt Control Register (USRIntCtl2) : 0xFF91 ← 0x00**

**Table 51: The USRIntCtl2 Register**

MSB								LSB
–	U3IS.6	U3IS.5	U3IS.4	–	U2IS.2	U2IS.1	U2IS.0	

**External Interrupt Control Register (USRIntCtl3) : 0xFF92 ← 0x00**

**Table 52: The USRIntCtl3 Register**

MSB								LSB
–	U5IS.6	U5IS.5	U5IS.4	–	U4IS.2	U4IS.1	U4IS.0	

**External Interrupt Control Register (USRIntCtl4) : 0xFF93 ← 0x00**

**Table 53: The USRIntCtl4 Register**

MSB								LSB
–	U7IS.6	U7IS.5	U7IS.4	–	U6IS.2	U6IS.1	U6IS.0	

### 1.7.10 Analog Voltage Comparator

The 73S1210F includes a programmable comparator that is connected to the ANA\_IN pin. The comparator can be configured to trigger an interrupt if the input voltage rises above or falls below a selectable threshold voltage. The comparator control register should not be modified when the analog interrupt (ANAIEN bit in the [INT6Ctl](#) register) is enabled to guard against any false interrupt that might be generated when modifying the threshold. The comparator has a built-in hysteresis to prevent the comparator from repeatedly responding to low-amplitude noise. This hysteresis is approximately 20mV. Interrupt control is handled in the [INT6Ctl](#) register.

#### Analog Compare Control Register (ACOMP): 0xFFD0 ← 0x00

**Table 54: The ACOMP Register**

MSB								LSB	
ANALVL	–	ONCHG	CPOL	CMPEN	TSEL.2	TSEL.1	TSEL.0		
Bit	Symbol	Function							
ACOMP.7	ANALVL	When read, indicates whether the input level is above or below the threshold. This is a real time value and is not latched, so it may change from the time of the interrupt trigger until read.							
ACOMP.6	–								
ACOMP.5	ONCHG	If set, the Ana_interrupt is invoked on any change above or below the threshold, bit 4 is ignored.							
ACOMP.4	CPOL	If set = 1, Ana_interrupt is invoked when signal rises above selected threshold. If set = 0, Ana_interrupt is invoked when signal goes below selected threshold (default).							
ACOMP.3	CMPEN	Enables power to the analog comparator. 1 = Enabled. 0 = Disabled (default).							
ACOMP.2	TSEL.2	Sets the voltage threshold for comparison to the voltage on pin ANA_IN. Thresholds are as follows:							
ACOMP.1	TSEL.1								
ACOMP.0	TSEL.0	TSEL.2	TSEL.1	TSEL.0	Voltage Threshold				
		0	0	0	1.00V				
		0	0	1	1.24V				
		0	1	0	1.40V				
		0	1	1	1.50V				
		1	0	0	1.75V				
		1	0	1	2.00V				
		1	1	0	2.30V				
		1	1	1	2.50V				

**External Interrupt Control Register (INT6Ctl): 0xFF95 ← 0x00****Table 55: The INT6Ctl Register**

MSB								LSB
	–	–	VFTIEN	VFTINT	I2CIEN	I2CINT	ANIEN	ANINT
Bit	Symbol	Function						
INT6Ctl.7	–							
INT6Ctl.6	–							
INT6Ctl.5	VFTIEN	VDD fault interrupt enable.						
INT6Ctl.4	VFTINT	VDD fault interrupt flag.						
INT6Ctl.3	I2CIEN	I <sup>2</sup> C interrupt enabled.						
INT6Ctl.2	I2CINT	I <sup>2</sup> C interrupt flag.						
INT6Ctl.1	ANIEN	If ANIEN = 1 Analog Compare event interrupt is enabled. When masked (ANIEN = 0), ANINT (bit 0) may be set, but no interrupt is generated.						
INT6Ctl.0	ANINT	(Read Only) Set when the selected ANA_IN signal changes with respect to the selected threshold if Compare_Enable is asserted. Cleared on read of register.						

### 1.7.11 LED Driver

The 73S1210F provides a single dedicated output pin for driving an LED. The LED driver pin can be configured as a current source that will pull to ground to drive an LED that is connected to VDD without the need for an external current limiting resistor. This pin may be used as general purpose output with the programmed pull-down current and a strong (CMOS) pull-up, if enabled. The analog block must be enabled when this output is being used to drive the selected output current.

This pin may be used as an input with consideration of the programmed output current and level. The register bit when read, indicates the state of the pin.

#### LED Control Register (LEDCtl): 0xFFF3 ← 0xFF

**Table 56: The LEDCtl Register**

MSB								LSB
	–	LPUEN	ISET.1	ISET.0	–	–	–	LEDD0

Bit	Symbol	Function
LEDCtl.7	–	
LEDCtl.6	LPUEN	0 = Pull-ups are enabled for all of the LED pins.
LEDCtl.5	ISET.1	These two bits control the drive current (to ground) for the LED driver pin. Current levels are: 00 = 0ma(off) 01 = 2ma 10 = 4ma 11 = 10ma
LEDCtl.4	ISET.0	
LEDCtl.3	–	
LEDCtl.2	–	
LEDCtl.1	–	
LEDCtl.0	LEDD0	Write data controls output level of pin LED0. Read will report level of pin LED0.

### 1.7.12 I<sup>2</sup>C Master Interface

The 73S1210F includes a dedicated fast mode, 400kHz I<sup>2</sup>C Master interface. The I<sup>2</sup>C interface can read or write 1 or 2 bytes of data per data transfer frame. The MPU communicates with the interface through six dedicated SFR registers:

- Device Address ([DAR](#))
- Write Data ([WDR](#))
- Secondary Write Data ([SWDR](#))
- Read Data ([RDR](#))
- Secondary Read Data ([SRDR](#))
- Control and Status ([CSR](#))

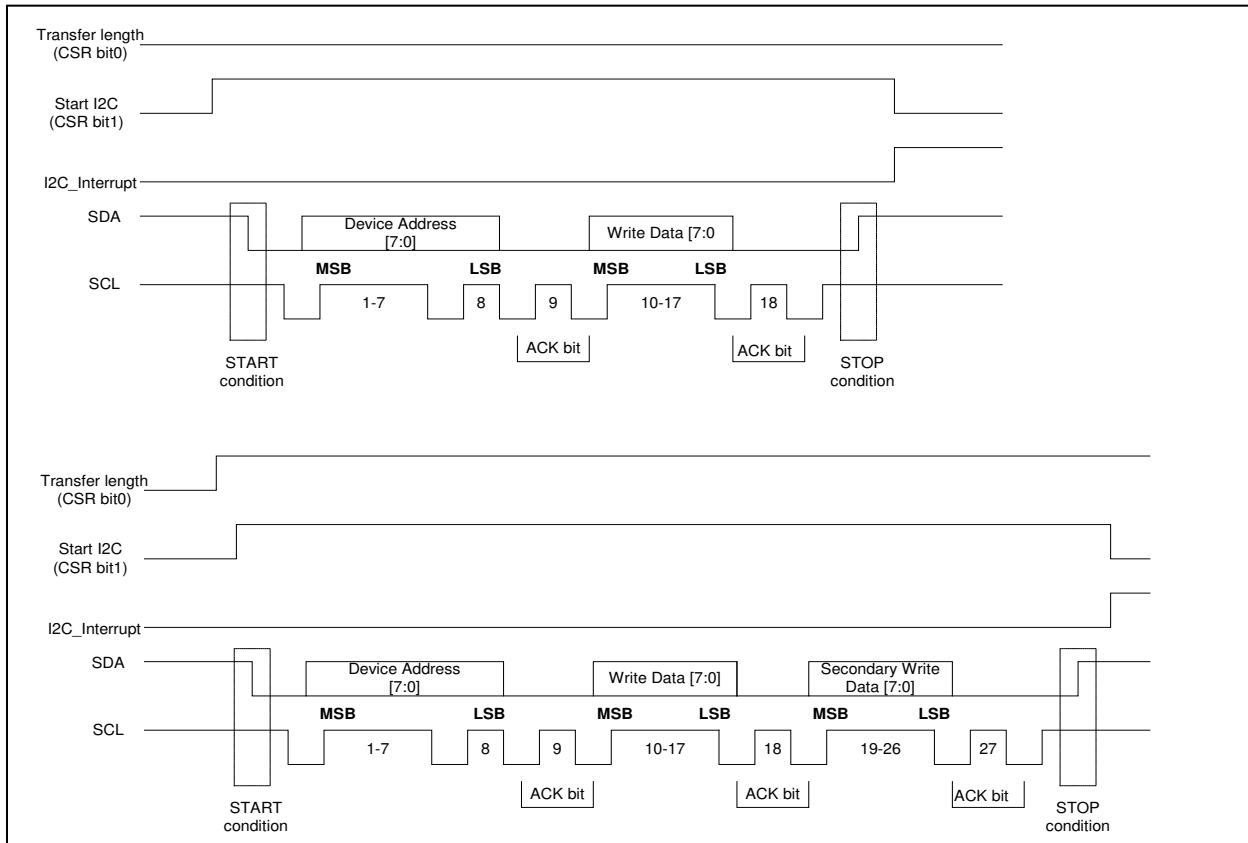
The [DAR](#) register is used to set up the slave address and specify if the transaction is a read or write operation. The [CSR](#) register sets up, starts the transaction and reports any errors that may occur. When the I<sup>2</sup>C transaction is complete, the I<sup>2</sup>C interrupt is reported via external interrupt 6. The I<sup>2</sup>C interrupt is automatically de-asserted when a subsequent I<sup>2</sup>C transaction is started. The I<sup>2</sup>C interface uses a 400kHz clock from the time-base circuits.

#### 1.7.12.1 I<sup>2</sup>C Write Sequence

To write data on the I<sup>2</sup>C Master Bus, the 80515 has to program the following registers according to the following sequence:

1. Write slave device address to Device Address register ([DAR](#)). The data contains 7 bits for the slave device address and 1 bit of op-code. The op-code bit should be written with a 0 to indicate a write operation.
2. Write data to Write Data register ([WDR](#)). This data will be transferred to the slave device.
3. If writing 2 bytes, set bit 0 of the Control and Status register ([CSR](#)) and load the second data byte to Secondary Write Data register ([SWDR](#)).
4. Set bit 1 of the [CSR](#) register to start I<sup>2</sup>C Master Bus.
5. Wait for I<sup>2</sup>C interrupt to be asserted. It indicates that the write on I<sup>2</sup>C Master Bus is done. Refer to information about the [INT6Ctl](#), [IEN1](#) and [IRCON](#) register for masking and flag operation.

[Figure 10](#) shows the timing of the I<sup>2</sup>C write mode:



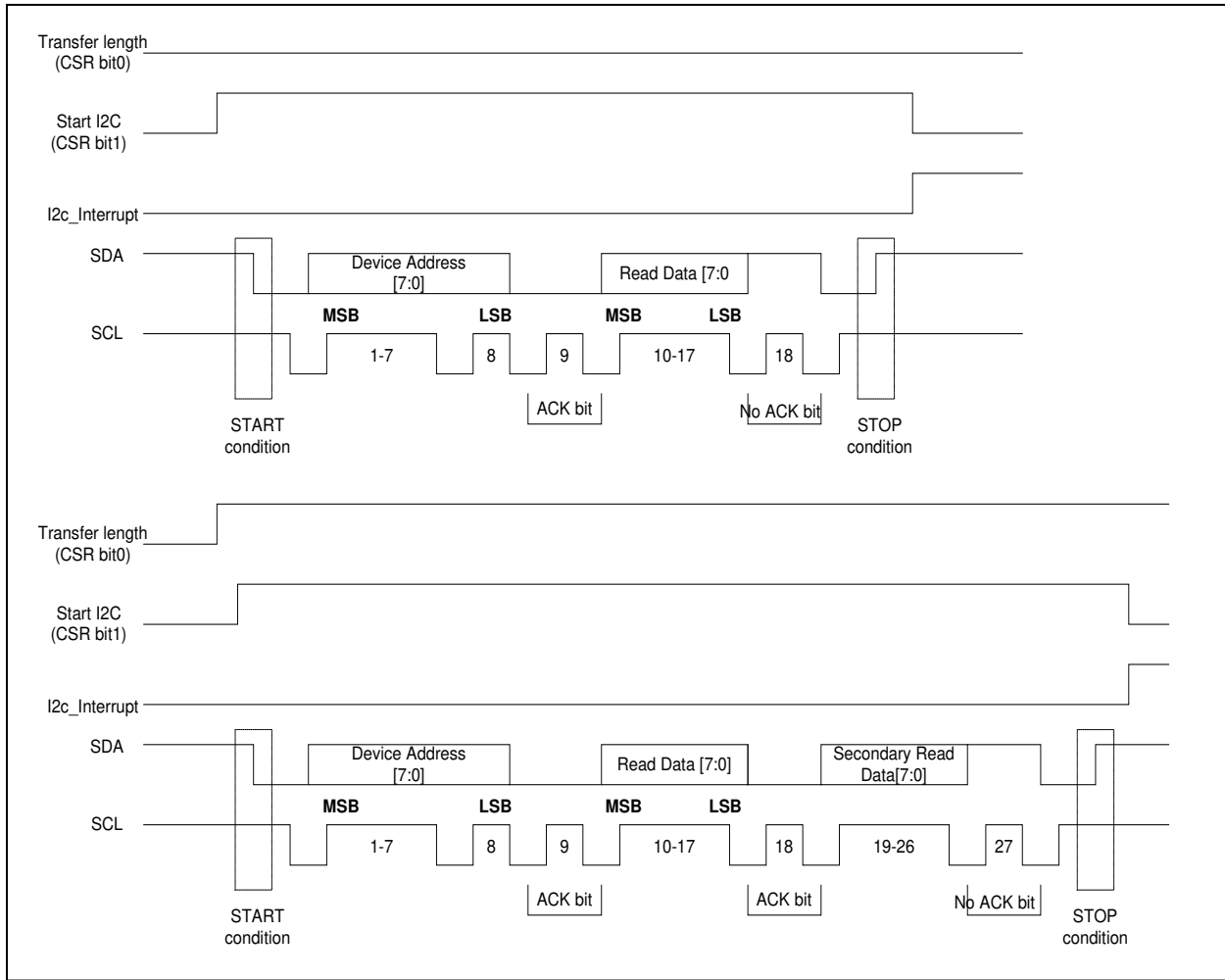
**Figure 10: I<sup>2</sup>C Write Mode Operation**

### 1.7.12.2 I<sup>2</sup>C Read Sequence

To read data on the I<sup>2</sup>C Master Bus from a slave device, the 80515 has to program the following registers in this sequence:

1. Write slave device address to Device Address register ([DAR](#)). The data contains 7 bits device address and 1 bit of op-code. The op-code bit should be written with a 1.
2. Write control data to Control and Status register. Write a 1 to bit 1 to start I<sup>2</sup>C Master Bus. Also write a 1 to bit 0 if the Secondary Read Data register ([SRDR](#)) is to be captured from the I<sup>2</sup>C Slave device.
3. Wait for I<sup>2</sup>C interrupt to be asserted. It indicates that the read operation on the I<sup>2</sup>C bus is done. Refer to information about the [INT6Cti](#), [IEN1](#) and [IRCON](#) registers for masking and flag operation.
4. Read data from the Read Data register ([RDR](#)).
5. Read data from Secondary Read Data register ([SRDR](#)) if bit 0 of Control and Status register ([CSR](#)) is written with a 1.

Figure 11 shows the timing of the I<sup>2</sup>C read mode:



**Figure 11: I<sup>2</sup>C Read Operation**



**Device Address Register (DAR): 0xFF80 ← 0x00****Table 57: The DAR Register**

MSB				LSB			
DVADR.6	DVADR.5	DVADR.4	DVADR.3	DVADR.2	DVADR.1	DVADR.0	I2CRW
Bit	Symbol	Function					
DAR.7	DVADR [0:6]	Slave device address.					
DAR.6							
DAR.5							
DAR.4							
DAR.3							
DAR.2							
DAR.1							
DAR.0	I2CRW	If set = 0, the transaction is a write operation. If set=1, read.					

**I2C Write Data Register (WDR): 0XFF81 ← 0x00****Table 58: The WDR Register**

MSB				LSB			
WDR.7	WDR.6	WDR.5	WDR.4	WDR.3	WDR.2	WDR.1	WDR.0
Bit	Function						
WDR.7	Data to be written to the I <sup>2</sup> C slave device.						
WDR.6							
WDR.5							
WDR.4							
WDR.3							
WDR.2							
WDR.1							
WDR.0							

**I2C Secondary Write Data Register (SWDR): 0XFF82 ← 0x00****Table 59: The SWDR Register**

MSB				LSB			
SWDR.7	SWDR.6	SWDR.5	SWDR.4	SWDR.3	SWDR.2	SWDR.1	SWDR.0
Bit	Function						
SWDR.7	Second Data byte to be written to the I <sup>2</sup> C slave device if bit 0 (I2CLEN) of the Control and Status register (CSR) is set = 1.						
SWDR.6							
SWDR.5							
SWDR.4							
SWDR.3							
SWDR.2							
SWDR.1							
SWDR.0							

**I2C Read Data Register (RDR): 0XFF83 ← 0x00****Table 60: The RDR Register**

MSB				LSB			
RDR.7	RDR.6	RDR.5	RDR.4	RDR.3	RDR.2	RDR.1	RDR.0
Bit	Function						
RDR.7	Data read from the I <sup>2</sup> C slave device.						
RDR.6							
RDR.5							
RDR.4							
RDR.3							
RDR.2							
RDR.1							
RDR.0							

**I2C Secondary Read Data Register (SRDR): 0xFF84 ← 0x00****Table 61: The SRDR Register**

MSB				LSB			
SRDR.7	SRDR.6	SRDR.5	SRDR.4	SRDR.3	SRDR.2	SRDR.1	SRDR.0
Bit	Function						
SRDR.7	Second Data byte to be read from the I <sup>2</sup> C slave device if bit 0 (I2CLEN) of the Control and Status register (CSR) is set = 1.						
SRDR.6							
SRDR.5							
SRDR.4							
SRDR.3							
SRDR.2							
SRDR.1							
SRDR.0							

**I2C Control and Status Register (CSR): 0xFF85 ← 0x00****Table 62: The CSR Register**

MSB					LSB		
–	–	–	–	–	AKERR	I2CST	I2CLEN
Bit	Symbol	Function					
CSR.7	–						
CSR.6	–						
CSR.5	–						
CSR.4	–						
CSR.3	–						
CSR.2	AKERR	Set to 1 if acknowledge bit from Slave Device is not 0. Automatically reset when the new bus transaction is started.					
CSR.1	I2CST	Write a 1 to start I <sup>2</sup> C transaction. Automatically reset to 0 when the bus transaction is done. This bit should be treated as a “busy” indicator on reading. If it is high, the serial read/write operations are not completed and no new address or data should be written.					
CSR.0	I2CLEN	Set to 1 for 2 byte read or write operations. Set to 0 for 1-byte operations.					

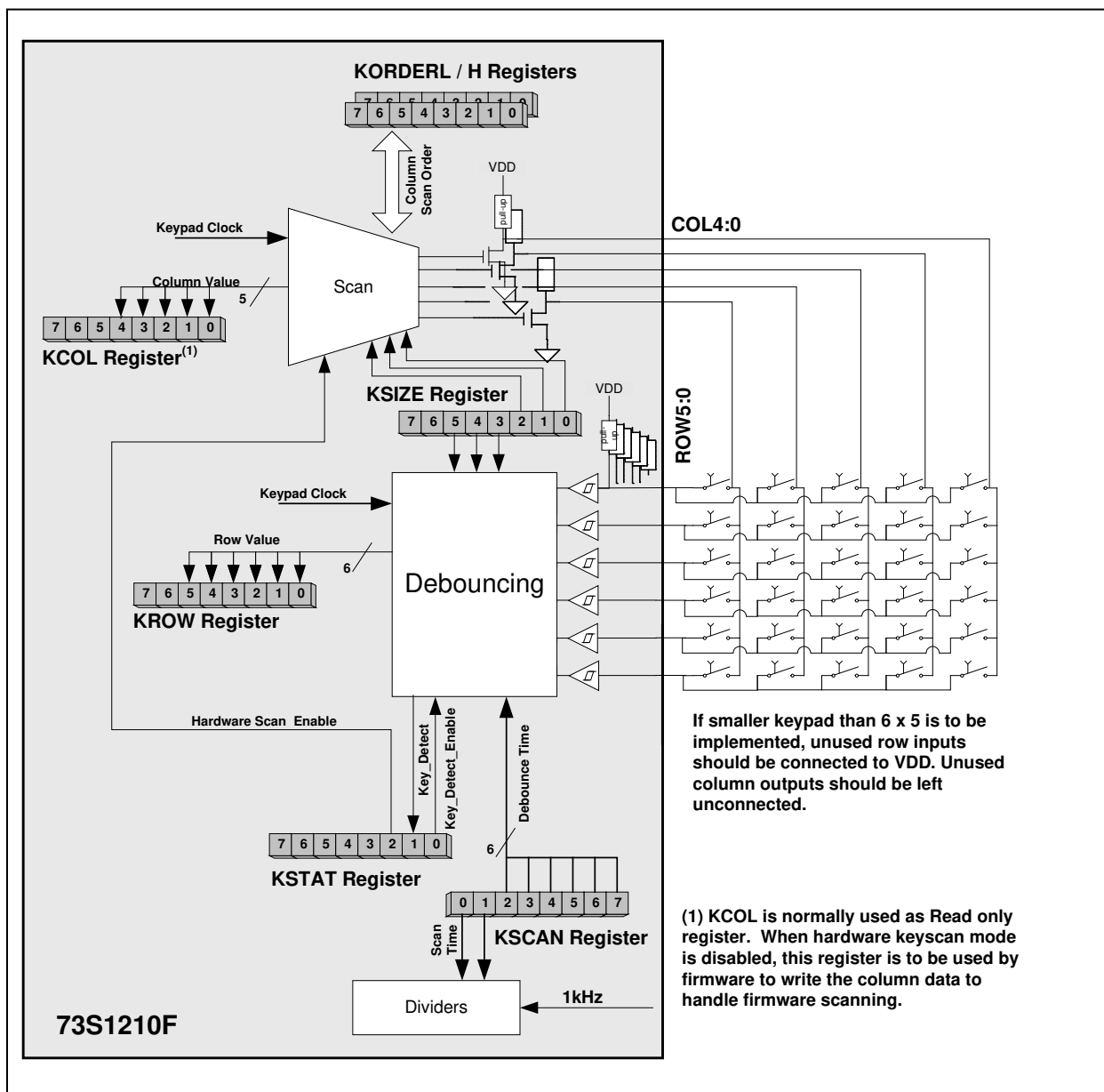
**External Interrupt Control Register (INT6Ctl): 0xFF95 ← 0x00****Table 63: The INT6Ctl Register**

MSB	–	–	VFTIEN	VFTINT	I2CIEN	I2CINT	ANIEN	ANINT	LSB
-----	---	---	--------	--------	--------	--------	-------	-------	-----

Bit	Symbol	Function
INT6Ctl.7	–	
INT6Ctl.6	–	
INT6Ctl.5	VFTIEN	VDD fault interrupt enable.
INT6Ctl.4	VFTINT	VDD fault interrupt flag.
INT6Ctl.3	I2CIEN	When set = 1, the I <sup>2</sup> C interrupt is enabled.
INT6Ctl.2	I2CINT	When set = 1, the I <sup>2</sup> C transaction has completed. Cleared upon the start of a subsequent I <sup>2</sup> C transaction.
INT6Ctl.1	ANIEN	Analog compare interrupt enable.
INT6Ctl.0	ANINT	Analog compare interrupt flag.

### 1.7.13 Keypad Interface

The 73S1210F supports a 30-button (6 rows x 5 columns) keypad (SPST Mechanical Contact Switches) interface using 11 dedicated I/O pins. Figure 12 shows a simplified block diagram of the keypad interface.



There are five drive lines (outputs) corresponding to columns and 6 sense lines (inputs) corresponding to rows. Hysteresis and pull-ups are provided on all inputs (rows), which eliminate the need for external resistors in the keypad. Key scanning happens by asserting one of the 5 column lines low and looking for a low on a sense line indicating that a key is pressed (switch closed) at the intersection of the drive/sense (column/row) line in the keypad. Key detection is performed by hardware with an incorporated debounce timer. Debouncing time is adjustable through the [KSCAN](#) register. Internal hardware circuitry performs column scanning at an adjustable scanning rate and column scanning order through registers [KSCAN](#) and [KORDERL / KORDERH](#). Key scanning is disabled at reset and must be enabled by firmware. When a valid key is detected, an interrupt is generated and the valid value of the pressed key is automatically

written into the **KCOL** and **KROW** registers. The keypad interface uses a 1kHz clock derived from the 12MHz crystal. The clock is enabled by setting bit 6 – **KBEN** – in the **MCLKCtl** register (see the **Oscillator and Clock Generation** section) to carry out scanning and debouncing. The keypad size can be adjusted within the **KSIZE** register.

Normal scanning is performed by hardware when the **SCNEN** bit is set at 1 in the **KSTAT** register. **Figure 13** shows the flowchart of how the hardware scanning operates. In order to minimize power, scanning does not occur until a key-press is detected. Once hardware key scanning is enabled, the hardware drives all column outputs low and waits for a low to be detected on one of the inputs. When a low is detected on any row, and before key scanning starts, the hardware checks that the low level is still detected after a debounce time. The debounce time is defined by firmware in the **KSCAN** register (bits 7:0, **DBTIME**). Debounce times from 4ms to 256ms in 4ms increments are supported. If a key is not pressed after the debounce time, the hardware will go back to looking for any input to be low. If a key is confirmed to be pressed, key scanning begins.

Key scanning asserts one of the 5 drive lines (**COL 4:0**) low and looks for a low on a sense line indicating that a key is pressed at the intersection of the drive/sense line in the keypad. After all sense lines have been checked without a key-press being detected, the next column line is asserted. The time between checking each sense line is the scan time and is defined by firmware in the **KSCAN** register (bits 0:1 – **SCTIME**). Scan times from 1ms to 4ms are supported. Scanning order does not affect the scan time. This scanning continues until the entire keypad is scanned. If only one key is pressed, a valid key is detected. Simultaneous key presses are not considered as valid (If two keys are pressed, no key is reported to firmware).

Possible scrambling of the column scan order is provided by means of the **KORDERL** and **KORDERH** registers that define the order of column scanning. Values in these registers must be updated every time a new keyboard scan order is desired. It is not possible to change the order of scanning the sense lines. The column and row intersection for the detected valid key are stored in the **KCOL** and **KROW** registers. When a valid key is detected, an interrupt is generated. Firmware can then read those registers to determine which key had been pressed. After reading the **KCOL** and **KROW** registers, the firmware can update the **KORDERL** / **KORDERH** registers if a new scan order is needed. When the **SCNEN** bit is enabled in the **KSTAT** register, the **KCOL** and **KROW** registers are only updated after a valid key has been identified. The hardware does not wait for the firmware to service the interrupt in order to proceed with the key scanning process. Once the valid key (or invalid key – e.g. two keys pressed) is detected, the hardware waits for the key to be released. Once the key is released, the debounce timer is started. If the key is not still released after the debounce time, the debounce counter starts again. After a key release, all columns will be driven low as before and the process will repeat waiting for any key to be pressed. When the **SCNEN** bit is disabled, all drive outputs are set to the value in the **KCOL** register. If firmware clears the **SCNEN** bit in the middle of a key scan, the **KCOL** register contains the last value stored in there which will then be reflected on the output pins. A bypass mode is provided so that the firmware can do the key scanning manually (**SCNEN** bit must be cleared). In bypass mode, the firmware writes/reads the Column and Row registers to perform the key scanning.

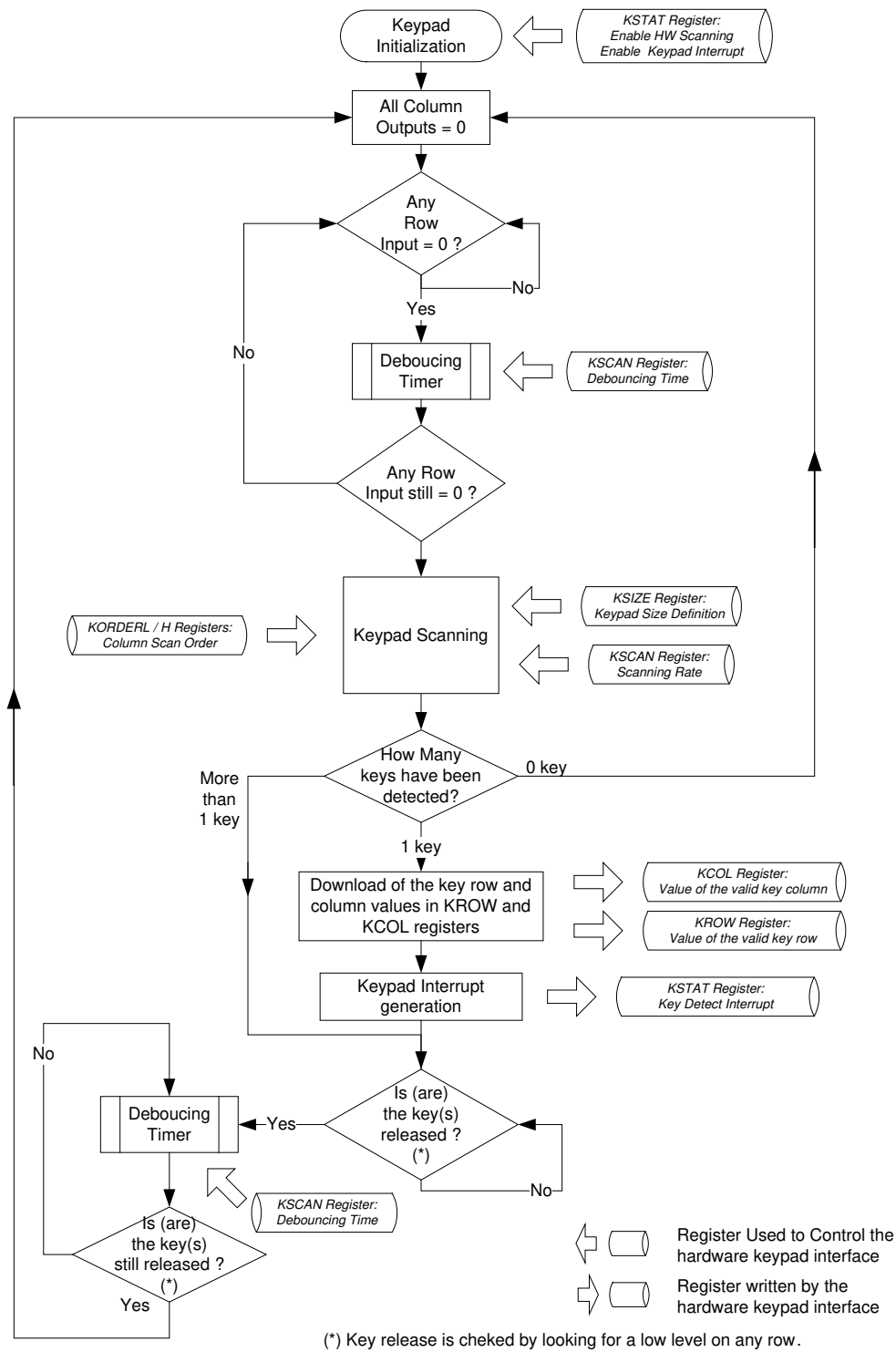


Figure 13: Keypad Interface Flow Chart

**Keypad Column Register (KCOL): 0xD1 ← 0x1F**

This register contains the value of the column of a key detected as valid by the hardware. In bypass mode, this register firmware writes directly this register to carry out manual scanning.

**Table 64: The KCOL Register**

MSB	–	–	–	COL.4	COL.3	COL.2	COL.1	COL.0	LSB
-----	---	---	---	-------	-------	-------	-------	-------	-----

Bit	Symbol	Function
KCOL.7	–	
KCOL.6	–	
KCOL.5	–	
KCOL.4	COL.4	Drive lines bit mapped to corresponding with pins COL(4:0). When a key is detected, firmware reads this register to determine column. In bypass (S/W keyscan) mode, Firmware writes this register directly. 0x1E = COL(0) low, all others high. 0x0F = COL(4) low, all others high. 0x1F = COL(4:0) all high.
KCOL.3	COL.3	
KCOL.2	COL.2	
KCOL.1	COL.1	
KCOL.0	COL.0	

**Keypad Row Register (KROW): 0xD2 ← 0x3F**

This register contains the value of the row of a key detected as valid by the hardware. In bypass mode, this register firmware reads directly this register to carry out manual detection.

**Table 65: The KROW Register**

MSB	–	–	ROW.5	ROW.4	ROW.3	ROW.2	ROW.1	ROW.0	LSB
-----	---	---	-------	-------	-------	-------	-------	-------	-----

Bit	Symbol	Function
KROW.7	–	
KROW.6	–	
KROW.5	ROW.6	Sense lines bit mapped to correspond with pins ROW(5:0). When key detected, firmware reads this register to determine row. In bypass mode, firmware reads rows and has to determine if there was a key press or not. 0x3E = ROW(0) low, all others high. 0x1F = ROW(5) low, all others high. 0x3F = ROW(5:0) all high.
KROW.4	ROW.4	
KROW.3	ROW.3	
KROW.2	ROW.2	
KROW.1	ROW.1	
KROW.0	ROW.0	



**Keypad Scan Time Register (KSCAN): 0xD3 ← 0x00**

This register contains the values of scanning time and debouncing time.

**Table 66: The KSCAN Register**

MSB					LSB		
DBTIME.5	DBTIME.4	DBTIME.3	DBTIME.2	DBTIME.1	DBTIME.0	SCTIME.1	SCTIME.0
Bit	Symbol	Function					
KSCAN.7	DBTIME.5	Debounce time in 4ms increments. 1 = 4ms de-bounce time, 0x3F = 252ms, 0x00 = 256ms. Key presses and key releases are debounced by this amount of time.					
KSCAN.6	DBTIME.4						
KSCAN.5	DBTIME.3						
KSCAN.4	DBTIME.2						
KSCAN.3	DBTIME.1						
KSCAN.2	DBTIME.0						
KSCAN.1	SCTIME.1	Scan time in ms. 01 = 1ms, 02 = 2ms, 00 = 3ms, 00 = 4ms. Time between checking each key during keypad scanning.					
KSCAN.0	SCTIME.0						

**Keypad Control/Status Register (KSTAT): 0xD4 ← 0x00**

This register is used to control the hardware keypad scanning and detection capabilities, as well as the keypad interrupt control and status.

**Table 67: The KSTAT Register**

MSB				LSB			
–	–	–	–	KEYCLK	HWSCEN	KEYDET	KYDTEN
Bit	Symbol	Function					
KSTAT.7	–						
KSTAT.6	–						
KSTAT.5	–						
KSTAT.4	–						
KSTAT.3	KEYCLK	The current state of the keyboard clock can be read from this bit.					
KSTAT.2	HWSCEN	Hardware Scan Enable – When set, the hardware will perform automatic key scanning. When cleared, the firmware must perform the key scanning manually (bypass mode).					
KSTAT.1	KEYDET	Key Detect – When HWSCEN = 1, this bit is set causing an interrupt that indicates a valid key press was detected and the key location can be read from the Keypad Column and Row registers. When HWSCEN = 0, this bit is an interrupt which indicates a falling edge on any Row input if all Row inputs had been high previously (note: multiple Key Detect interrupts may occur in this case due to the keypad switch bouncing). In all cases, this bit is cleared when read. When HWSCEN = 0 and the keypad interface 1kHz clock is disabled, a key press will still set this bit and cause an interrupt.					
KSTAT.0	KYDTEN	Key Detect Enable – When set, the KEYDET bit can cause an interrupt and when cleared the KEYDET cannot cause an interrupt. KEYDET can still get set even if the interrupt is not enabled.					

**Keypad Scan Time Register (KSIZE): 0xD5 ← 0x00**

This register is not applicable when HWSCEN is not set. Unused row inputs should be connected to VDD.

**Table 68: The KSIZE Register**

MSB								LSB	
–	–	ROWSIZ.2	ROWSIZ.1	ROWSIZ.0	COLSIZ.2	COLSIZ.1	COLSIZ.0		
Bit	Symbol	Function							
KSIZE.7	–								
KSIZE.6	–								
KSIZE.5	ROWSIZ.2	Defines the number of rows in the keypad. Maximum number is 6 given the number of row pins on the package. Allows for a reduced keypad size for scanning.							
KSIZE.4	ROWSIZ.1								
KSIZE.3	ROWSIZ.0								
KSIZE.2	COLSIZ.2	Defines the number of columns in the keypad. Maximum number is 5 given the number of column pins on the package. Allows for a reduced keypad size for scanning.							
KSIZE.1	COLSIZ.1								
KSIZE.0	COLSIZ.0								

**Keypad Column LS Scan Order Register (KORDERL): 0xD6 ← 0x00**

In the **KORDERL** and **KORDERH** registers, Column Scan Order(14:0) is grouped into 5 sets of 3 bits each. Each set determines which column (COL(4:0) pin) to activate by loading the column number into the 3 bits. When in HW\_Scan\_Enable mode, the hardware will step through the sets from 1Col to 5Col (up to the number of columns in Colsize) and scan the column defined in the 3 bits. To scan in sequential order, set a counting pattern with 0 in set 0, and 1 in set 1, and 2 in set 2, and 3 in set 3, and 4 in set 4. The firmware should update this as part of the interrupt service routine so that the new scan order is loaded prior to the next key being pressed. For example, to scan COL(0) first, 1Col(2:0) should be loaded with 000'b. To scan COL(4) fifth, 5Col(2:0) should be loaded with 100'b.

**Table 69: The KORDERL Register**

MSB				LSB			
3COL.1	3COL.0	2COL.2	2COL.1	2COL.0	1COL.2	1COL.1	1COL.0

Bit	Symbol	Function
KORDERL.7	3COL.1	Column to scan 3 <sup>rd</sup> (lsb's).
KORDERL.6	3COL.0	
KORDERL.5	2COL.2	Column to scan 2 <sup>nd</sup> .
KORDERL.4	2COL.1	
KORDERL.3	2COL.0	
KORDERL.2	1COL.2	Column to scan 1 <sup>st</sup> .
KORDERL.1	1COL.1	
KORDERL.0	1COL.0	

**Keypad Column MS Scan Order Register (KORDERH): 0xD7 ← 0x00****Table 70: The KORDERH Register**

MSB				LSB			
–	5COL.2	5COL.1	5COL.0	4COL.2	4COL.1	4COL.0	3COL.2

Bit	Symbol	Function
KORDERH.7	–	
KORDERH.6	5COL.2	Column to scan 5 <sup>th</sup> .
KORDERH.5	5COL.1	
KORDERH.4	5COL.0	
KORDERH.3	4COL.2	Column to scan 4 <sup>th</sup> .
KORDERH.2	4COL.1	
KORDERH.1	4COL.0	
KORDERH.0	3COL.2	Column to scan 3 <sup>rd</sup> (msb).

**External Interrupt Control Register (INT5Ctl): 0xFF94 ← 0x00****Table 71: The INT5Ctl Register**

MSB	LSB
PDMUX	KPIEN KPINT

Bit	Symbol	Function
INT5Ctl.7	PDMUX	Power down multiplexer control.
INT5Ctl.6	–	
INT5Ctl.5	–	
INT5Ctl.4	–	
INT5Ctl.3	–	
INT5Ctl.2	–	
INT5Ctl.1	KPIEN	Enables Keypad interrupt when set = 1.
INT5Ctl.0	KPINT	This bit indicates the Keypad logic has set Key_Detect bit and a key location may be read. Cleared on read of register.

**1.7.14 Emulator Port**

The emulator port, consisting of the pins E\_RST, E\_TCLK and E\_RXTX, provides control of the MPU through an external in-circuit emulator. The E\_TBUS[3:0] pins, together with the E\_ISYNC/BRKRQ, add trace capability to the emulator. The emulator port is compatible with the ADM51 emulators manufactured by Signum Systems™.

The signals of the emulator port have weak pull-ups. Adding resistor footprints for signals E\_RST, E\_TCLK and E\_RXTX on the PCB is recommended. If necessary, adding 10kΩ pull-up resistors on E\_TCLK and E\_RXTX and a 3kΩ on E\_RST will help the emulator operate normally if a problem arises. If code trace capability is needed on this interface, 20pF capacitors (to ground) need to be added to allow the trace function capability to run properly. These capacitors should be attached to the TBUS0:3 and ISBR signals.

### 1.7.15 Smart Card Interface Function

The 73S1210F integrates one ISO-7816 (T=0, T=1) UART, one complete ICC electrical interface as well as an external smart card interface to allow multiple smart cards to be connected using the Teridian 8010 family of interface devices. Figure 14 shows the simplified block diagram of the card circuitry (UART + interfaces), with detail of dedicated XRAM registers.

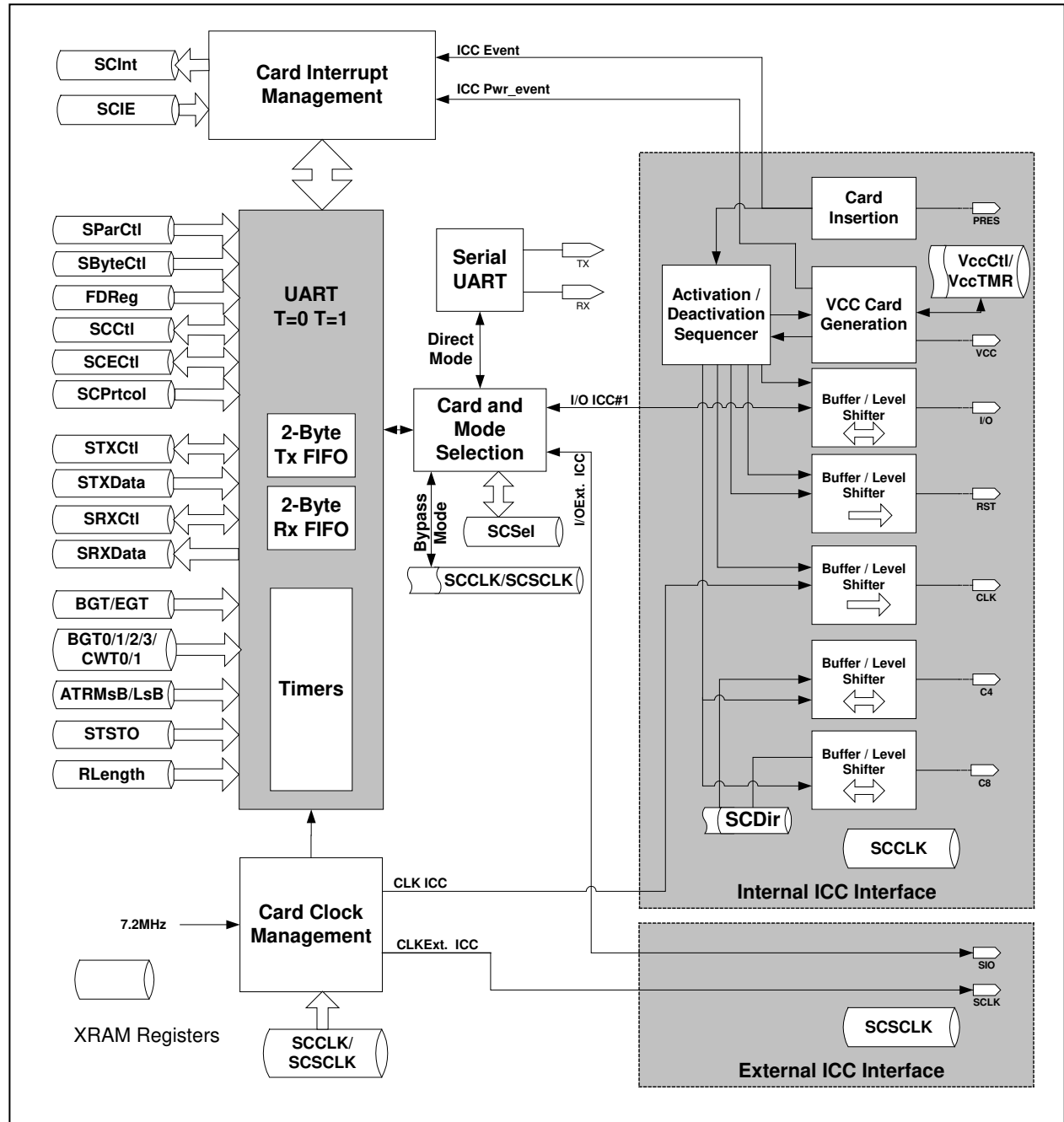


Figure 14: Smart Card Interface Block Diagram

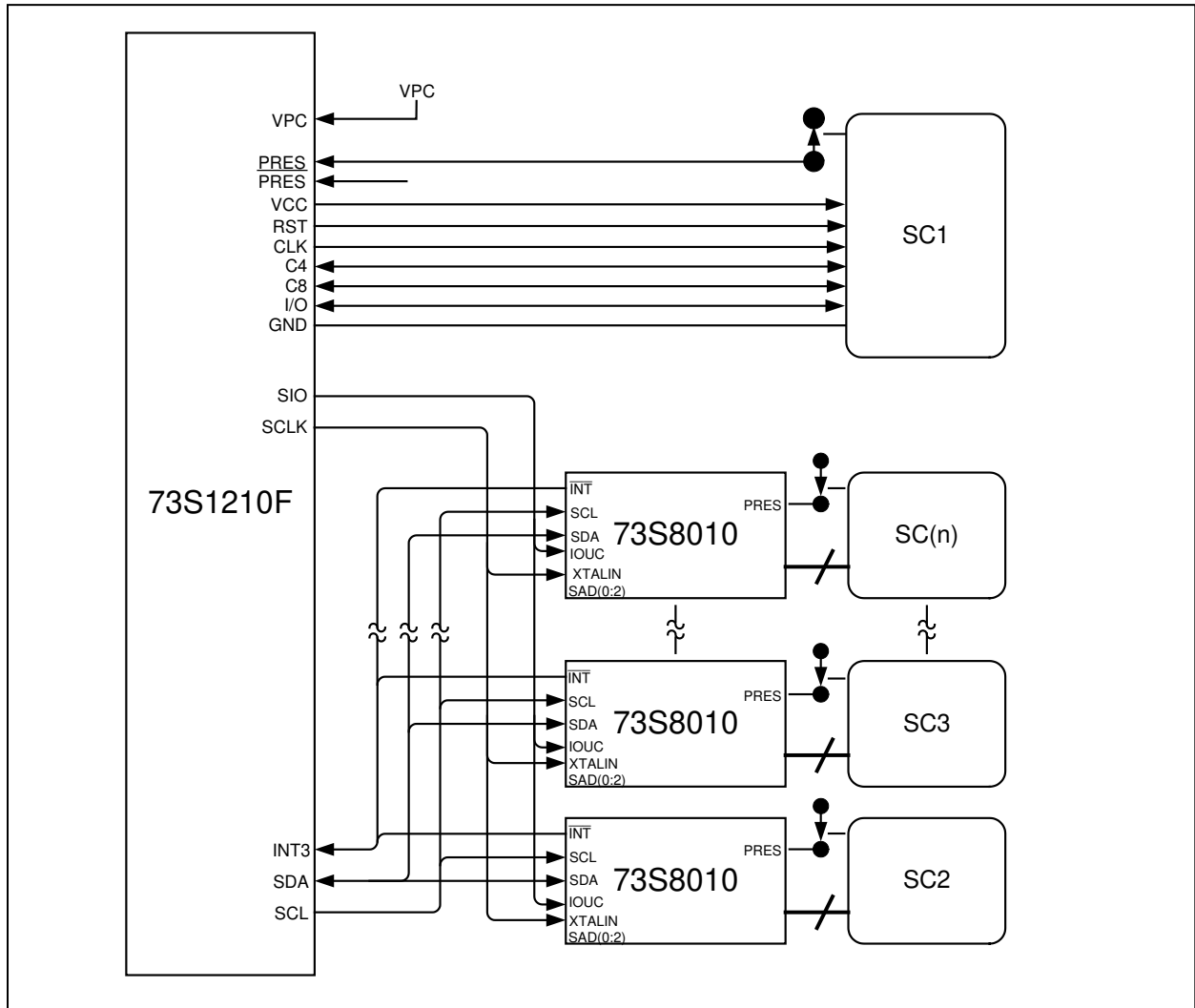
Card interrupts are managed through two dedicated registers: **SCIE** (Interrupt Enable to define which interrupt is enabled) and **SCInt** (Interrupt status). They allow the firmware to determine the source of an interrupt, that can be a card insertion / removal, card power fault, or a transmission (TX) or reception (RX) event / fault. It should be noted that even when card clock is disabled, an ICC interrupt can be generated

on a card insertion / removal to allow power saving modes. Card insertion / removal is generated from the respective card switch detection inputs (whose polarity is programmable).

The built-in ICC Interface has a linear regulator ( $V_{CC}$  generator) capable of driving 1.8, 3.0 and 5.0V smart cards in accordance with the ISO 7816-3 and EMV4.1 standards. This converter uses the  $V_P$  (5.5V nominal) input supply source. See the power supply management section above for more detail.

Auxiliary I/O lines C4 and C8 are only provided for the built-in interface. If support for the auxiliary lines is necessary for the external smart card interface, they need to be handled manually through the USR GPIO pins. The external 73S8010x devices directly connect the I/O (SIO) and clock (SCLK) signals and control is handled via the I<sup>2</sup>C interface.

Figure 15 shows how multiple 8010 devices can be connected to the 73S1210F.



**Figure 15: External Smart Card Interface Block Diagram**

### 1.7.15.1 ISO 7816 UART

An embedded ISO 7816 (hardware) UART is provided to control communications between a smart card and the 73S1210F MPU. The UART can be shared between the one built-in ICC interface and the external ICC interface. Selection of the desired interface is made by register SCSel. Control of the external interface is handled by the I<sup>2</sup>C interface for any external 73S8010x device. The following is a list of features for the ISO 7816 UART:

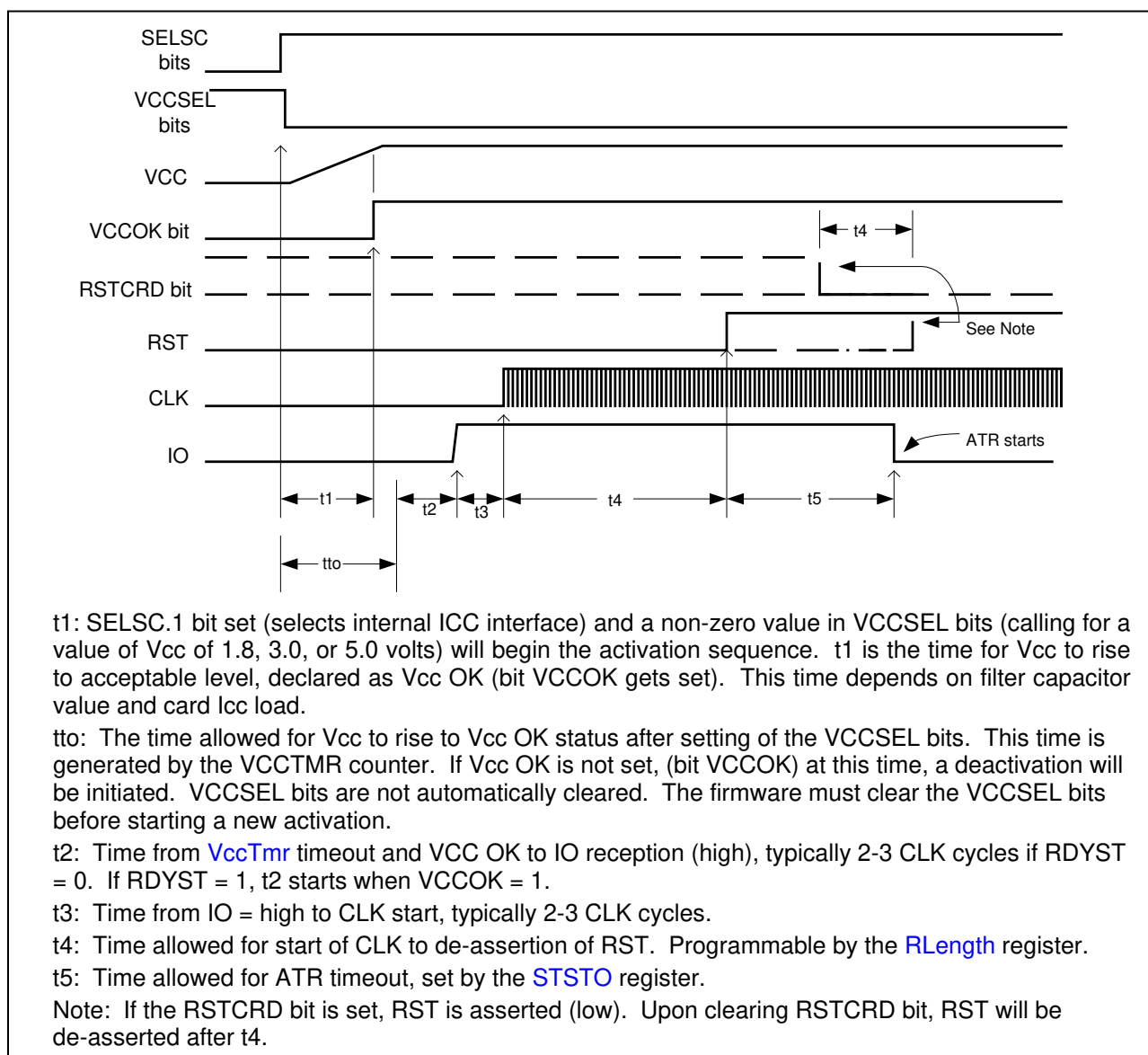
- Two-byte FIFO for temporary data storage on both TX and Rx data.
- Parity checking in T=0. This feature can be enabled/disabled by firmware. Parity error reporting to firmware and Break generation to ICC can be controlled independently.
- Parity error generation for test purposes.
- Retransmission of last byte if ICC indicates T=0 parity error. This feature can be enabled/disabled by firmware.
- Deletion of last byte received if ICC indicates T=0 parity error. This feature can be enabled/disabled by firmware.
- CRC/LRC generation and checking. CRC/LRC is automatically inserted into T=1 data stream by the hardware. This feature can be enabled/disabled by firmware.
- Support baud rates: 115200, 57600, 38400, 28800, 19200, 14400, 9600 under firmware control (assuming 12MHz crystal) with various F/D settings.
- Firmware manages F/D. All F/D combinations are supported in which F/D is directly divisible by 31 or 32 (i.e. F/D is a multiple of either 31 or 32).
- Flexible ETU clock generation and control.
- Detection of convention (direct or indirect) character TS. This affects both polarity and order of bits in byte. Convention can be overridden by firmware.
- Supports WTX Timeout with an expanded Wait Time Counter (28 bits).
- A Bypass Mode is provided to bypass the hardware UART in order for the software to emulate the UART (for non-standard operating modes). In such a case, the I/O line value is reflected in SFR [SCCti](#) or [SCECti](#) respectively for the built-in or external interfaces. This mode is appropriate for some synchronous and non T=0 / T=1 cards.

The single integrated smart card UART is capable of supporting T=0 and T=1 cards in hardware therefore offloading the bit manipulation tasks from the firmware. The embedded firmware instructs the hardware which smart card it should communicate with at any point in time. Firmware reconfigures the UART as required when switching between smart cards. When the 73S1210F has transmitted a message with an expected response, the firmware should not switch the UART to another smart card until the first smart card has responded. If the smart card responds while another smart card is selected, that first smart card's response will be ignored.

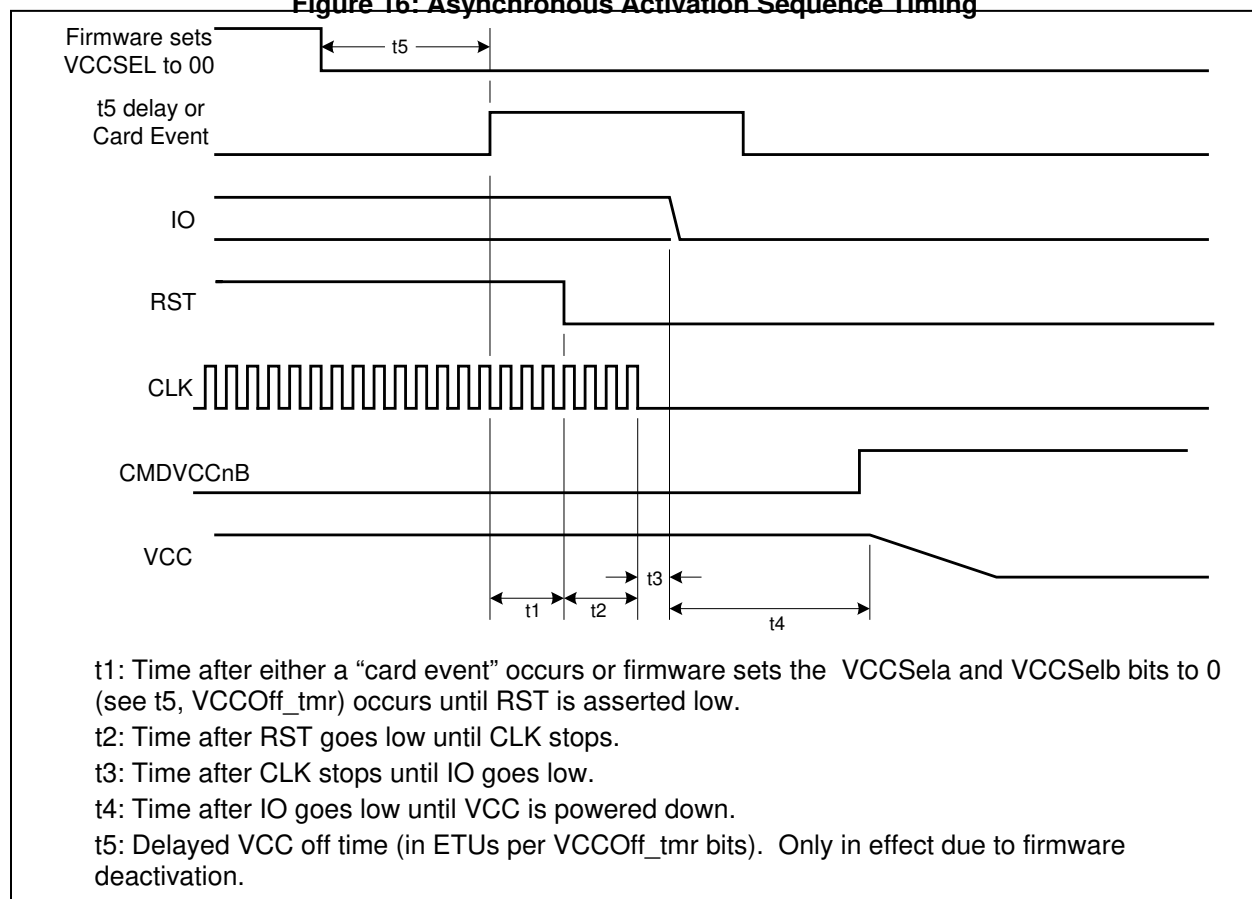
### 1.7.15.2 Answer to Reset Processing

A card insertion event generates an interrupt to the firmware, which is then responsible for the configuration of the electrical interface, the UART and activation of the card. The activation sequencer goes through the power up sequence as defined in the ISO 7816-3 specification. An asynchronous activation timing diagram is shown in

Figure 16. After the card reset is de-asserted, the firmware instructs the hardware to look for a TS byte that begins the ATR response. If a response is not provided within the pre-programmed timeout period, an interrupt is generated and the firmware can then take appropriate action, including instructing the 73S1210F to begin a deactivation sequence. Once commanded, the deactivation sequencer goes through the power down sequence as defined in the ISO 7816-3 specification. If an ATR response is received, the hardware looks for a TS byte that determines direct/inverse convention. The hardware handles the indirect convention conversion such that the embedded firmware only receives direct convention. This feature can be disabled by firmware within [SByteCtl](#) register. Parity checking and break generation is performed on the TS byte unless disabled by firmware. If during the card session, a card removal, over-current or other error event is detected, the hardware will automatically perform the deactivation sequence and then generate an interrupt to the firmware. The firmware can then perform any other error handling required for proper system operation. Smart card RST, I/O and CLK, C4, C8 shall be low before the end of the deactivation sequence. Figure 17 shows the timing for a deactivation sequence.

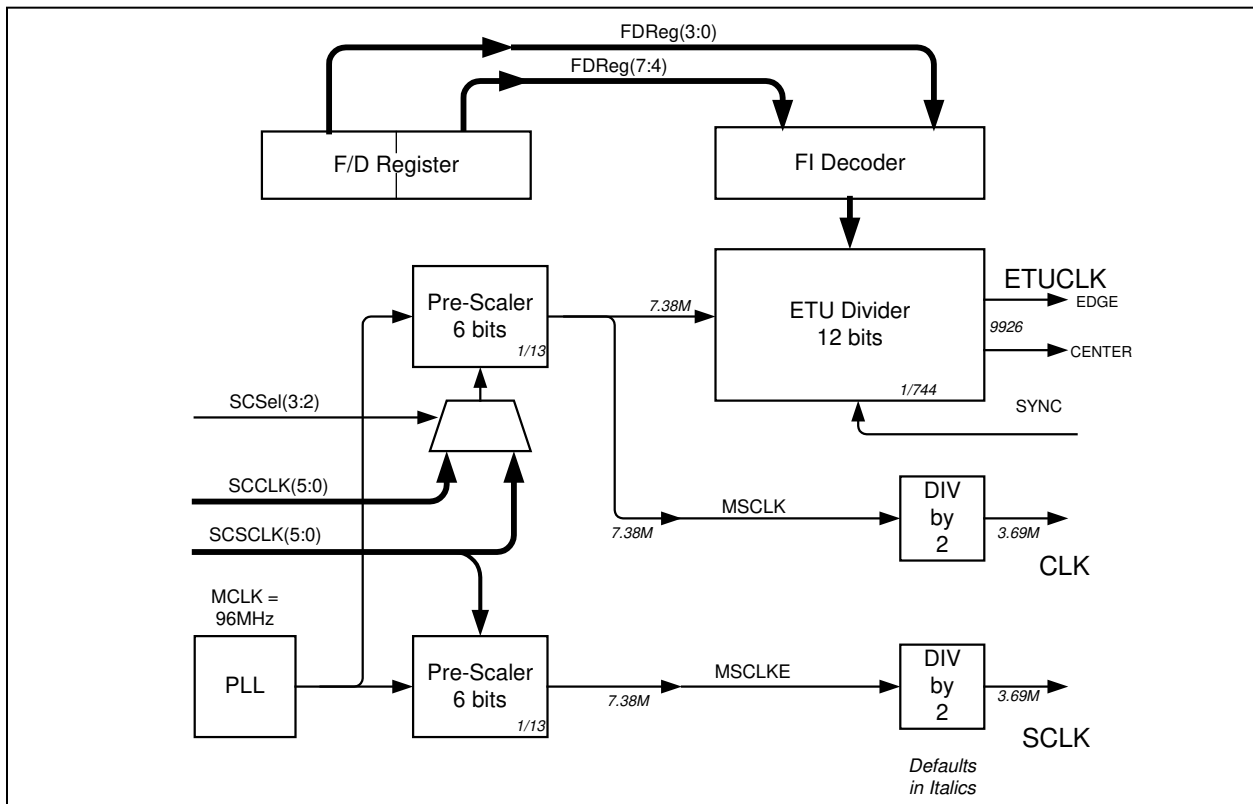




**Figure 16: Asynchronous Activation Sequence Timing****Figure 17: Deactivation Sequence**

### 1.7.15.3 Data Reception/Transmission

When a 12Mhz crystal is used, the smart card UART will generate a 3.69Mhz (default) clock to both smart card interfaces. This will allow approximately 9600bps (1/ETU) communication during ATR (ISO 7816 default). As part of the PPS negotiation between the smart card and the reader, the firmware may determine that the smart card parameters F & D may be changed. After this negotiation, the firmware may change the ETU by writing to the SFR [FDReg](#) to adjust the ETU and CLK. The firmware may also change the smart card clock frequency by writing to the SFR [SCCLK](#) ([SCECLK](#) for external interface). Independent clock frequency control is provided to each smart card interface. Clock stop high or Clock stop low is supported in asynchronous mode. [Figure 18](#) shows the ETU and CLK control circuits. The firmware determines when clock stop is supported by the smart card and when it is appropriate to go into that mode (and when to come out of it). The smart card UART is clocked by the same clock that is provided to the selected smart card. The transition between smart card clocks is handled in hardware to eliminate any glitches for the UART during switchover. The external smart card clock is not affected when switching the UART to communicate with the internal smart card.



**Figure 18: Smart Card CLK and ETU Generation**

There are two, two-byte FIFOs that are used to buffer transmit and receive data. During a T=0 processing, if a parity error is detected by the 73S1210F during message reception, an error signal (BREAK) will be generated to the smart card. The byte received will be discarded and the firmware notified of the error. Break generation and receive byte dropping can be disabled under firmware control. During the transmission of a byte, if an error signal (BREAK) is detected, the last byte is retransmitted again and the firmware notified. Retransmission can be disabled by firmware. When a correct byte is received, an interrupt is generated to the firmware, which then reads the byte from the receive FIFO. Receive overruns are detected by the hardware and reported via an interrupt. During transmission of a message, the firmware will write bytes into the transmit FIFO. The hardware will send them to the smart card. When the last byte of a message has been written, the firmware will need to set the LASTTX bit in the **STXCtl** SFR. This will cause the hardware to insert the CRC/LRC if in a T=1 protocol mode. CRC/LRC generation/checking is only provided during T=1 processing. Firmware will need to instruct the smart function to go into receive mode after this last transmit data byte if it expects a response from the smart card. At the end of the smart card response, the firmware will put the interface back into transmit mode if appropriate.

The hardware can check for the following card-related timeouts:

- Character Waiting Time (CWT)
- Block Waiting Time (BWT)
- Initial Waiting Time (IWT)

The firmware will load the Wait Time with the appropriate value for the operating mode at the appropriate time. [Figure 19](#) shows the guard, block, wait and ATR time definitions. If a timeout occurs, an interrupt will be generated and the firmware can take appropriate recovery steps. Support is provided for adding additional guard times between characters using the Extra Guard Time register (**EGT**), and between the last byte received by the 73S1210F and the first byte transmitted by the 73S1210F using the Block Guard Time register (**BGT**). Other than the protocol checks described above, the firmware is responsible for all protocol checking and error recovery.

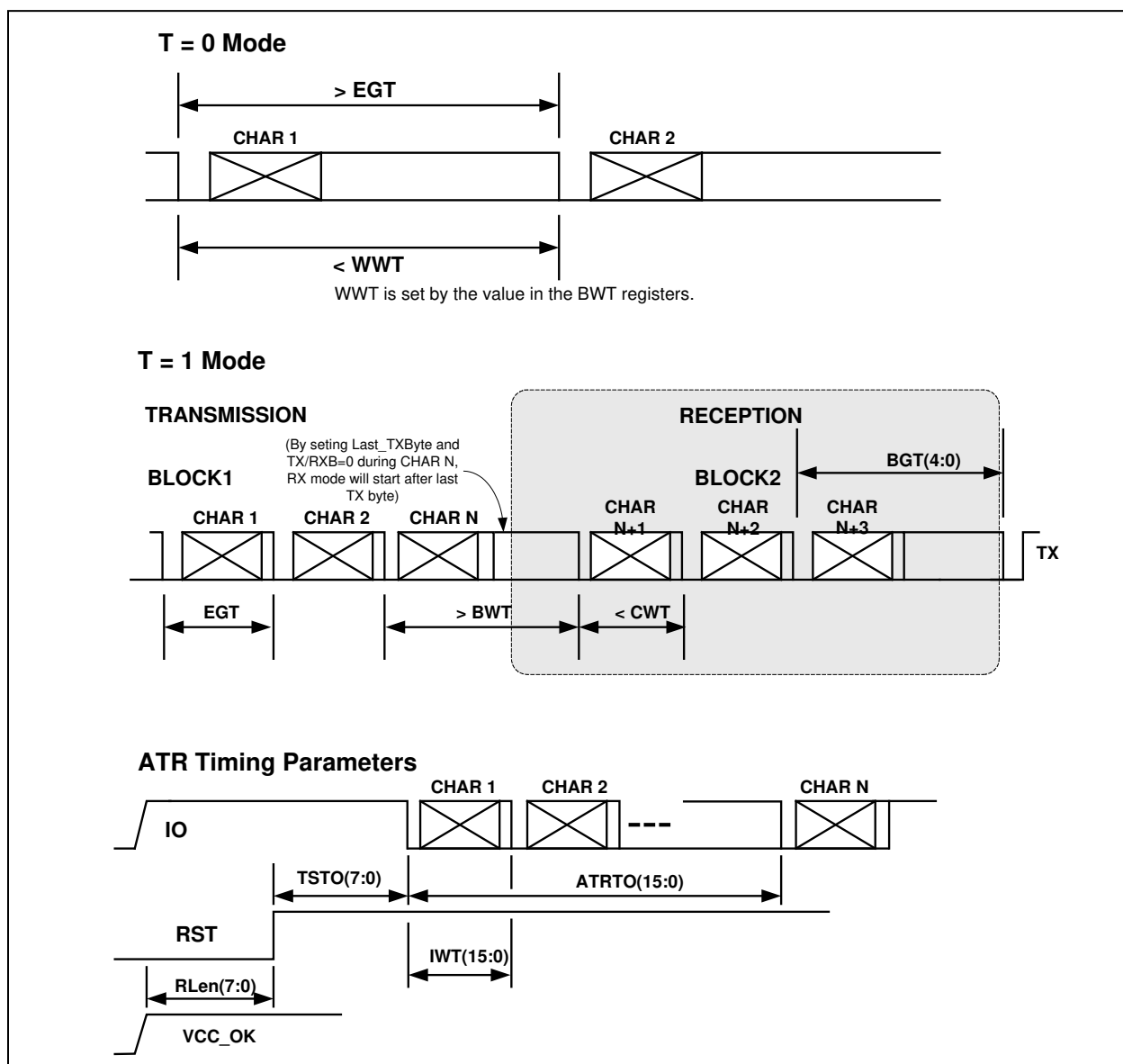


Figure 19: Guard, Block, Wait and ATR Time Definitions

#### 1.7.15.4 Bypass Mode

It is possible to bypass the smart card UART in order for the firmware to support non-T=0/T=1 smart cards. This is called Bypass mode. In this mode the embedded firmware will communicate directly with the selected smart card and drive I/O during transmit and read I/O during receive in order to communicate with the smart card. In this mode, ATR processing is under firmware control. The firmware must sequence the interface signals as required. Firmware must perform TS processing, parity checking, break generation and CRC/LRC calculation (if required).

#### 1.7.15.5 Synchronous Operation Mode

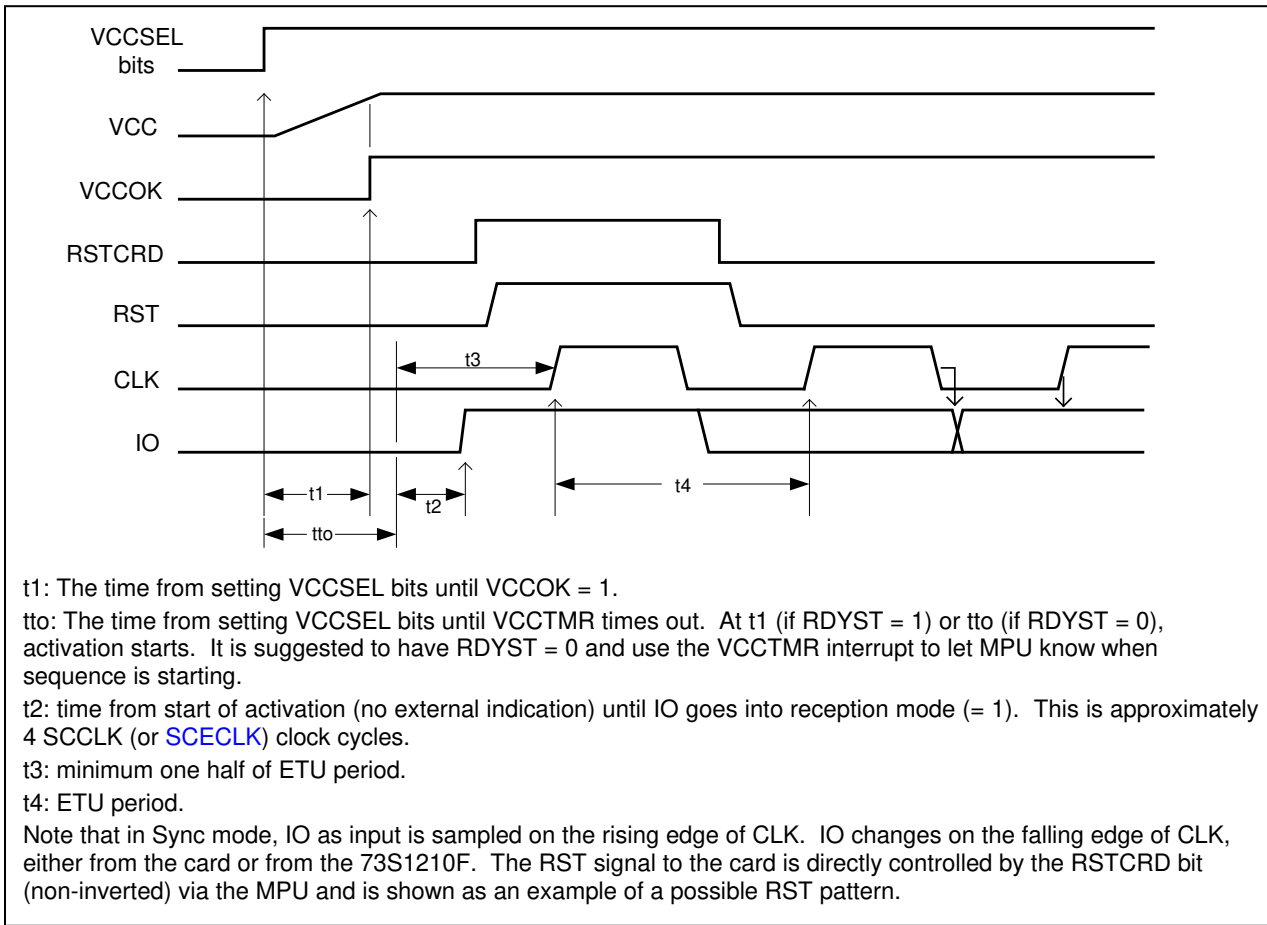
The 73S1210F supports synchronous operation. When sync mode is selected for either interface, the CLK signal is generated by the ETU counter. The values in `c`, `SCCLK`, and `SCECLK` must be set to obtain the desired sync CLK rate. There is only one ETU counter and therefore, in sync mode, the interface must be selected to obtain a smart card clock signal. In sync mode, input data is sampled on the rise of CLK, and output data is changed on the fall of CLK.

### Special Notes Regarding Synchronous Mode Operation

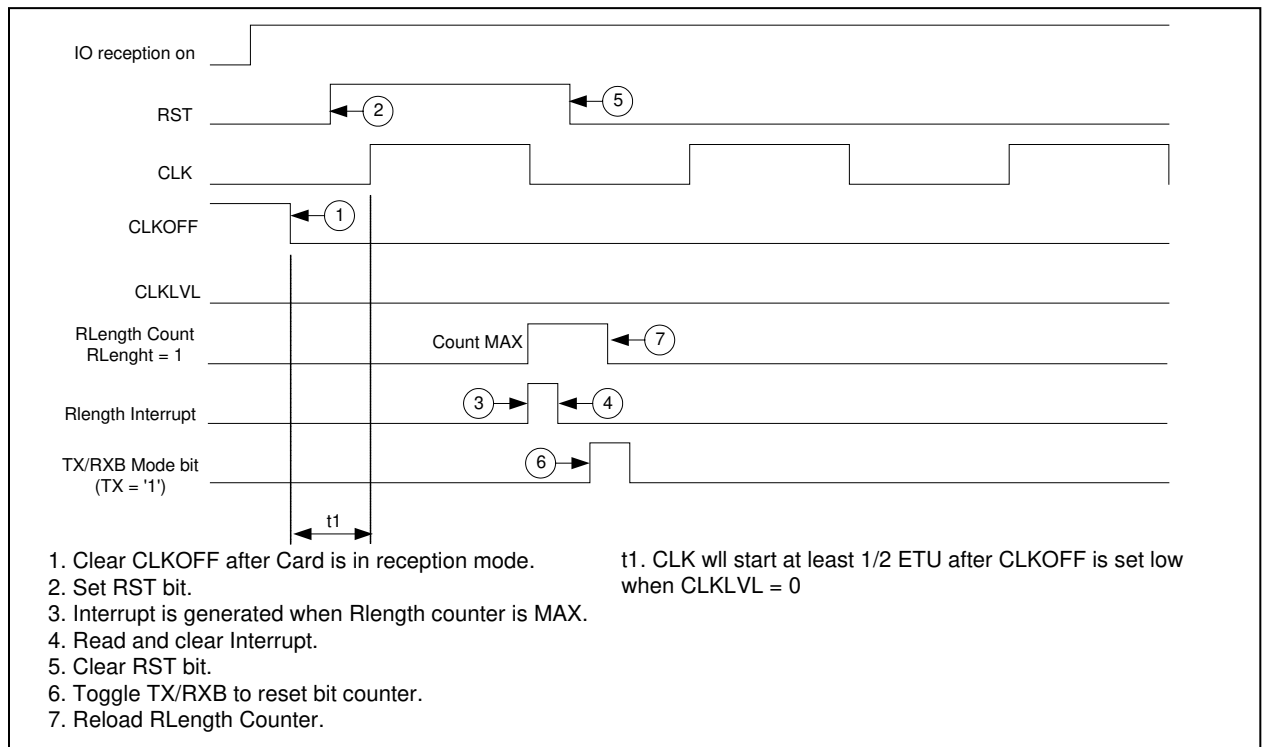
When the SCISYN or SCESNC bits ([SPrtcol](#), bit 7, bit 5, respectively) are set, the selected smart card interface operates in synchronous mode and there are changes in the definition and behavior of pertinent register bits and associated circuitry. The following requirements are to be noted:

1. The source for the smart card clock (CLK or SCLK) is the ETU counter. Only the actively selected interface can have a running synchronous clock. In contrast, an unselected interface may have a running clock in the asynchronous mode of operation.
2. The control bits CLKLVL, SCLKLVL, CLKOFF, and SCLKOFF are functional in synchronous mode. When the CLKOFF bit is set, it will not truncate either the logic low or logic high period when the (stop at) level is of opposite polarity. The CLK/SCLK signal will complete a correct logic low or logic high duty cycle before stopping at the selected level. The CLK “start” is a result of the falling edge of the CLKOFF bit. Setting clock to run when it is stopped low will result in a half period of low before going high. Setting clock to run when it is stopped high will result in the clock going low immediately and then running at the selected rate with 50% duty cycle (within the limitations of the ETU divisor value).
3. The RLen(7:0) is configured to count the falling edges of the ETU clock (CLK or SCLK) after it has been loaded with a value from 1 to 255. A value of 0 disables the counting function and RLen functions such as I/O source selection (I/O signal bypasses the FIFOs and is controlled by the [SCCLK/SCECLK](#) SFRs). When the RLen counter reaches the “max” (loaded) value, it sets the WAITTO interrupt ([SCInt](#), bit 7), which is maskable via WTOIEN ([SCIE](#), bit 7). It must be reloaded in order to start the counting/clocking process again. This allows the processor to select the number of CLK cycles and hence, the number of bits to be read or written to/from the card.
4. The FIFO is not clocked by the first CLK (falling) edge resulting from a CLKOFF de-assertion (a clock start event) when the CLK was stopped in the high state and RLen has been loaded but not yet clocked.
5. The state of the pin IO or SIO is sampled on the rising edge of CLK/SCLK and stored in bit 5 of the [SCCtl/SCECtl](#) register.
6. When RLen = max or 0 and I2CMODE= 1 ([STXCtl](#), b7), the IO or SIO signal is directly controlled by the data and direction bits in the respective [SCCtl](#) and [SCECtl](#) register. The state of the data in the TX FIFO is bypassed.
7. In the [SPrtcol](#) register, bit 6 (MODE9/8B) becomes active. When set, the RXData FIFO will read nine-bit words with the state of the ninth bit being readable in [SRXCtl](#), bit 7 (B9DAT). The RXDAV interrupt will occur when the ninth bit has been clocked in (rising edge of CLK or SCLK).
8. Care must be taken to clear the RX and TX FIFOs at the start of any transaction. The user shall read the RX FIFO until it indicates empty status. Reading the TX FIFO twice will reset the input byte pointer and the next write to the TX FIFO will load the byte to the “first out” position. Note that the bit pointer (serializer/deserializer) is reset to bit 0 on any change of the TX/RXD bit.

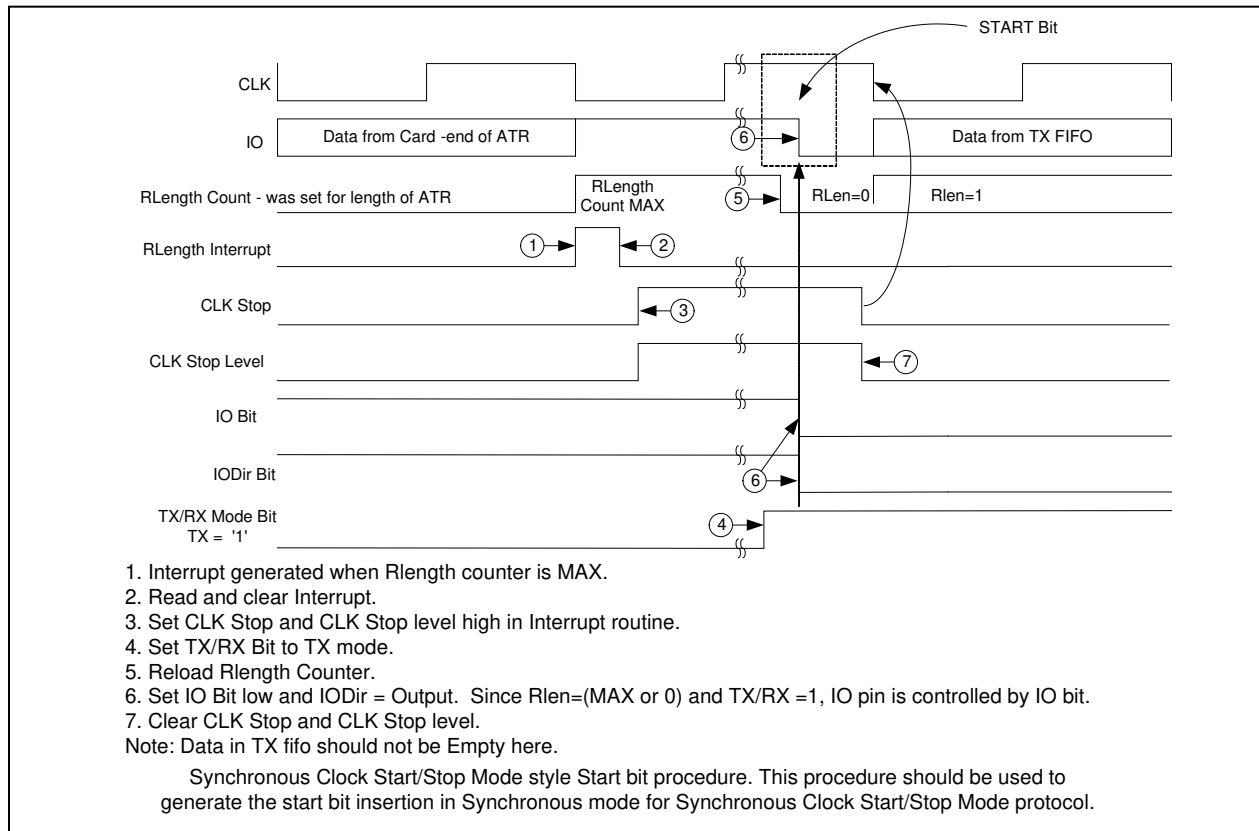
Special bits that are only active for sync mode include: [SRXCtl](#), b7 “BIT9DAT”, [SPrtcol](#), b6 “MODE9/8B”, [STXCtl](#), b7 “I2CMODE”, and the definition of [SCInt](#), b7, which was “WAITTO”, becomes RLenINT interrupt, and [SCIE](#), b7, which was “WTOIEN”, becomes RLenIEN.



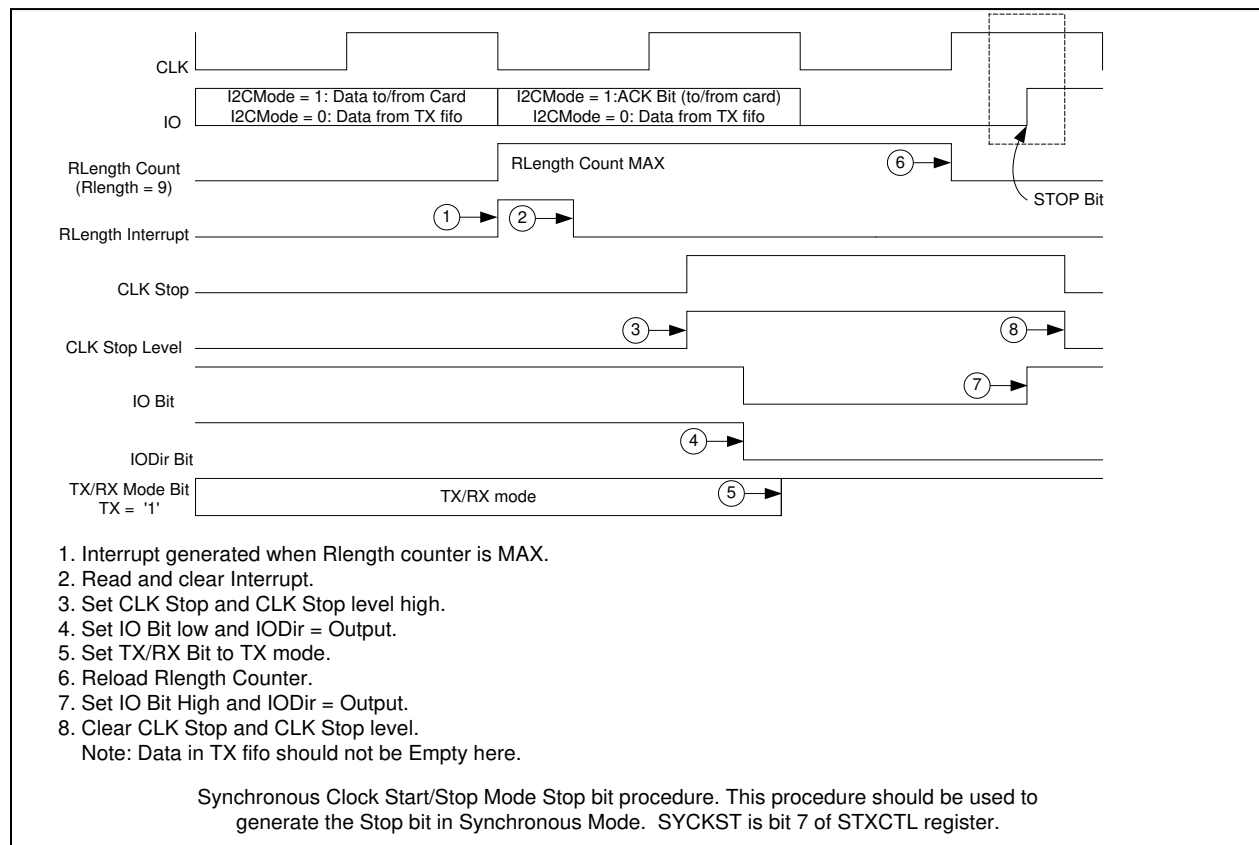
**Figure 20: Synchronous Activation**



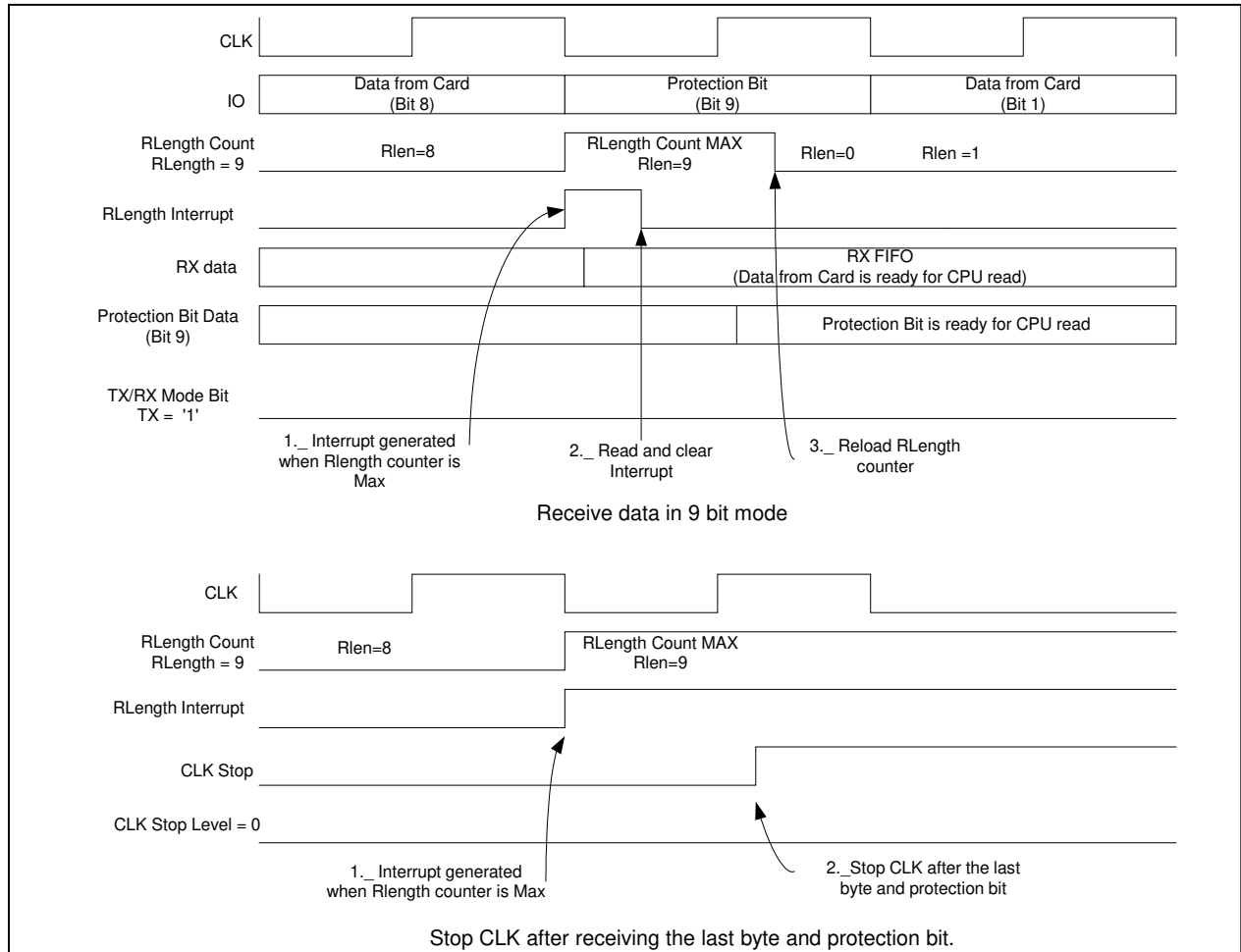
**Figure 21: Example of Sync Mode Operation: Generating/Reading ATR Signals**



**Figure 22: Creation of Synchronous Clock Start/Stop Mode Start Bit in Sync Mode**



**Figure 23: Creation of Synchronous Clock Start/Stop Mode Stop Bit in Sync Mode**



**Figure 24: Operation of 9-bit Mode in Sync Mode**

Synchronous card operation is broken down into three primary types. These are commonly referred to as 2-wire, 3-wire and I2C synchronous cards. Each card type requires different control and timing and therefore requires different algorithms to access. Teridian has created an application note to provide detailed algorithms for each card type. Refer to the application note titled “73S12xxF Synchronous Card Design Application Note”.

### 1.7.15.6 Smart Card SFRs

#### Smart Card Select Register (SCSel): 0xFE00 ← 0x00

The Smart Card Select register is used to determine which smart card interface is using the ISO UART. The internal Smart Card has integrated 7816-3 compliant sequencer circuitry to drive an external smart card interface. The external smart card interface relies on 73S8010 parts to generate the ISO 7816-3 compatible signals and sequences. Multiple 73S8010 devices can be connected to the external smart card interface.

**Table 72: The SCSel Register**

MSB				LSB			
-	-	-	-	SELSC.1	SELSC.0	BYPASS	-
Bit	Symbol	Function					
SCSel.7	-						
SCSel.6	-						
SCSel.5	-						
SCSel.4	-						
SCSel.3	SELSC.1	Select Smart Card Interface - These bits select the interface that is using the ISO UART. These bits do not activate the interface. Activation is performed by the <a href="#">VccCtl</a> register.					
SCSel.2	SELSC.0						
SCSel.1	BYPASS	1 = Enabled, 0 = Disabled. When enabled, ISO UART is bypassed and the I/O line is controlled via the <a href="#">SCCtl</a> and <a href="#">SCECtl</a> registers.					
SCSel.0	-						



**Smart Card Interrupt Register (SCInt): 0xFE01 ← 0x00**

When the smart card interrupt is asserted, the firmware can read this register to determine the actual cause of the interrupt. The bits are cleared when this register is read. Each interrupt can be disabled by the Smart Card Interrupt Enable register. Error processing must be handled by the firmware. This register relates to the interface that is active – see the [SCSel](#) register (above).

**Table 73: The SCInt Register**

MSB								LSB
WAITTO	CRDEVT	VCCTMRI	RXDAV	TXEVT	TXSENT	TXERR	RXERR	
Bit	Symbol	Function						
SCInt.7	WAITTO	Wait Timeout - An ATR or card wait timeout has occurred. In sync mode, this interrupt is asserted when the RLen counter (it advances on falling edges of CLK/ETU) reaches the loaded (max) value. This bit is cleared when the SCInt register is read. When running in Synchronous Clock Stop Mode, this bit becomes RLenINT interrupt (set when the RLen counter reaches the terminal count).						
SCInt.6	CRDEVT	Card Event - A card event is signaled via pin DETCARD either when the Card was inserted or removed (read the <a href="#">CRDCtl</a> register to determine card presence) or there was a fault condition in the interface circuitry. This bit is functional even if the smart card logic clock is disabled and when the PWRDN bit is set. This bit is cleared when the SCInt register is read.						
SCInt.5	VCCTMRI	VCC Timer - This bit is set when the VCCTMR times out. This bit is cleared when the SCInt register is read.						
SCInt.4	RXDAV	Rx Data Available - Data was received from the smart card because the Rx FIFO is not empty. In bypass mode, this interrupt is generated on a falling edge of the smart card I/O line. After receiving this interrupt in bypass mode, firmware should disable it until the firmware has received the entire byte and is waiting for the next start delimiter. This bit is cleared when there is no RX data available in the RX FIFO.						
SCInt.3	TXEVT	TX Event - Set whenever the TXEMTY or TXFULL bits are set in the <a href="#">SRXCtl</a> SFR. This bit is cleared when the <a href="#">STXCtl</a> register is read.						
SCInt.2	TXSENT	TX Sent - Set whenever the ISO UART has successfully transmitted a byte to the smart card. Also set when a CRC/LRC byte is sent in T=1 mode. Will not be set in T=0 when a break is detected at the end of a byte (when break detection is enabled). This bit is cleared when the SCInt register is read.						
SCInt.1	TXERR	TX Error - An error was detected during the transmission of data to the smart card as indicated by either BREAKD or TXUNDR bit being set in the <a href="#">STXCtl</a> SFR. Additional information can be found in that register description. This bit is cleared when the <a href="#">STXCtl</a> register is read.						
SCInt.0	RXERR	RX Error - An error was detected during the reception of data from the smart card. Additional information can be found in the <a href="#">SRXCtl</a> register. This interrupt will be asserted for RXOVR, or RX Parity error events. This bit is cleared when the <a href="#">SRXCtl</a> register is read.						

**Smart Card Interrupt Enable Register (SCIE): 0xFE02 ← 0x00**

When set to 1, the respective condition can cause a smart card interrupt. When set to a 0, the respective condition cannot cause an interrupt. When disabled, the respective bit in the Smart Card Interrupt register can still be set, but it will not interrupt the MPU.

**Table 74: The SCIE Register**

MSB								LSB
WTOIEN	CDEVEN	VTMREN	RXDAEN	TXEVEN	TXSNTEN	TXEREN	RXEREN	
Bit	Symbol	Function						
SCIE.7	WTOIEN	Wait Timeout Interrupt Enable - Enable for ATR or Wait Timeout Interrupt. In sync mode, function is RLIEN (RLen = max.) interrupt enable.						
SCIE.6	CDEVEN	Card Event Interrupt Enable.						
SCIE.5	VTMREN	VCC Timer Interrupt Enable.						
SCIE.4	RXDAEN	Rx Data Available Interrupt Enable.						
SCIE.3	TXEVEN	TX Event Interrupt Enable.						
SCIE.2	TXSNTEN	TX Sent Interrupt Enable.						
SCIE.1	TXEREN	TX Error Interrupt Enable.						
SCIE.0	RXEREN	RX Error Interrupt Enable.						

**Smart Card V<sub>CC</sub> Control/Status Register (VccCtl): 0xFE03 ← 0x00**

This register is used to control the power up and power down of the integrated smart card interface. It is used to determine whether to apply 5V, 3V, or 1.8 to the smart card. Perform the voltage selection with one write operation, setting both VCCSEL.1 and VCCSEL.0 bits simultaneously. The VDDFLT bit (if enabled) will provide an emergency deactivation of the internal smart card slot. See the [VDD Fault Detect Function](#) section for more detail.

**Table 75: The VccCtl Register**

MSB								LSB
VCCSEL.1	VCCSEL.0	VDDFLT	RDYST	VCCOK	–	–	SCPWRDN	
Bit	Symbol	Function						
VccCtl.7	VCCSEL.1	Setting non-zero value for bits 7,6 will begin activation sequence with target Vcc as given below:						
		State	VCCSEL.1	VCCSEL.0	VCC			
		1	0	0	0V			
		2	0	1	1.8V			
		3	1	0	3.0V			
		4	1	1	5V			
VccCtl.6	VCCSEL.0	A card event or VCCOK going low will initiate a deactivation sequence. When the deactivation sequence for RST, CLK and I/O is complete, V <sub>CC</sub> will be turned off. When this type of deactivation occurs, the bits must be reset before initiating another activation.						
VccCtl.5	VDDFLT	When there is a VDD Fault event, this bit will be set = 0. This causes VCCSEL.1 and VCCSEL.0 bits to be immediately set = 0 to begin deactivation.						
VccCtl.4	RDYST	If this bit is set = 1, the activation sequence will start when bit VCCOK is set = 1. If not set, the deactivation sequence shall start when the VCCTMR times out.						
VccCtl.3	VCCOK	(Read only). Indicates that V <sub>CC</sub> output voltage is stable.						
VccCtl.2	–							
VccCtl.1	–							
VccCtl.0	SCPWRDN	This bit controls the power-off mode of the 73S1210F circuit. 1 = power off, 0 = normal operation. When in power down mode, V <sub>DD</sub> = 0V. V <sub>DD</sub> can only be turned on by pressing the ON/OFF switch or by application of 5V to V <sub>BUS</sub> . If V <sub>BUS</sub> power is available and SCPWRDN bit is set, it has no effect until V <sub>BUS</sub> is removed and V <sub>DD</sub> will shut off.						

**V<sub>CC</sub> Stable Timer Register (VccTmr): 0xFE04 ← 0x0F**

A programmable timer is provided to set the time from activation start (setting the VCCSEL.1 and VCCSEL.0 bits to non-zero) to when VCC\_OK is evaluated. VCC\_OK must be true at the end of this timer's programmed interval (t<sub>to</sub> in [Figure 16](#)) in order for the activation sequence to continue. If VCC\_OK is not true at the end of the interval (t<sub>to</sub>), the Card Event interrupt will be set, and a deactivation sequence shall begin including clearing of the VCCSEL bits.

**Table 76: The VccTmr Register**

MSB

LSB

OFFTMR.3	OFFTMR.2	OFFTMR.1	OFFTMR.0	VCCTMR.3	VCCTMR.2	VCCTMR.1	VCCTMR.0
----------	----------	----------	----------	----------	----------	----------	----------

Bit	Symbol	Function
VccTmr.7	OFFTMR.3	VCC Off Timer - The bits set the delay (in number of ETUs) for deactivation after the VCCSEL.1 and VCC SEL.0 have been set to 0. The time value is a count of the 32768Hz clock and is given by $t_{to} = \text{OFFTMR}(7:4) * 30.5\mu\text{s}$ . This delay does not affect emergency deactivations due to VDD Fault or card events. A value of 0000 results in no additional delay.
VccTmr.6	OFFTMR.2	
VccTmr.5	OFFTMR.1	
VccTmr.4	OFFTMR.0	
VccTmr.3	VCCTMR.3	VCC Timer - VCCOK must be true at the time set by the value in these bits in order for the activation sequence to continue. If not, the VCCSEL bits will be cleared. The time value is a count of the 32768Hz clock and is given by $t_{to} = \text{VCCTMR}(3:0) * 30.5\mu\text{s}$ . A value of 0000 results in no timeout, not zero time, and activation requires that RDYST is set and RDY goes high.
VccTmr.2	VCCTMR.2	
VccTmr.1	VCCTMR.1	
VccTmr.0	VCCTMR.0	

**Card Status/Control Register (CRDCtl): 0xFE05 ← 0x00**

This register is used to configure the card detect pin (DETCARD) and monitor card detect status. This register must be written to properly configure Debounce, Detect\_Polarity (= 0 or = 1), and the pull-up/down enable before setting CDETEN. The card detect logic is functional even without smart card logic clock. When the PWRDN bit is set = 1, no debounce is provided but card presence is operable.

**Table 77: The CRDCtl Register**

MSB	LSB						
DEBOUN	CDETEN	–	–	DETPOL	PUENB	PDEN	CARDIN

Bit	Symbol	Function
CRDCtl.7	DEBOUN	Debounce - When set = 1, this will enable hardware debounce of the card detect pin. The debounce function shall wait for 64ms of stable card detect assertion before setting the CARDIN bit. This counter/timer uses the keypad clock as a source of 1kHz signal. De-assertion of the CARDIN bit is immediate upon de-assertion of the card detect pin(s).
CRDCtl.6	CDETEN	Card Detect Enable - When set = 1, activates card detection input. Default upon power-on reset is 0.
CRDCtl.5	–	
CRDCtl.4	–	
CRDCtl.3	DETPOL	Detect Polarity - When set = 1, the DETCARD pin shall interpret a logic 1 as card present.
CRDCtl.2	PUENB	Enable pull-up current on DETCARD pin (active low).
CRDCtl.1	PDEN	Enable pull-down current on DETCARD pin.
CRDCtl.0	CARDIN	Card Inserted - (Read only). 1 = card inserted, 0 = card not inserted. A change in the value of this bit is a “card event.” A read of this bit indicates whether smart card is inserted or not inserted in conjunction with the DETPOL setting.

**TX Control/Status Register (STXCtl): 0xFE06 ← 0x00**

This register is used to control transmission of data to the smart card. Some control and some status bits are in this register.

**Table 78: The STXCtl Register**

MSB								LSB
I2CMODE	–	TXFULL	TXEMPTY	TXUNDR	LASTTX	TX/RXB	BREAKD	
Bit	Symbol	Function						
STXCtl.7	I2CMODE	I2C Mode - When in sync mode and this bit is set, and when the RLen count value = max or 0, the source of the smart card data for IO pin (or SIO pin) will be connected to the IO bit in <a href="#">SCCtl</a> (or <a href="#">SCECtl</a> ) register rather than the TX FIFO. See the description for the <a href="#">Protocol Mode Register</a> for more detail.						
STXCtl.6	–							
STXCtl.5	TXFULL	TX FIFO is full. Additional writes may corrupt the contents of the FIFO. This bit it will remain set as long as the TX FIFO is full. Generates a TX_Event interrupt upon going full.						
STXCtl.4	TXEMPTY	1 = TX FIFO is empty, 0 = TX FIFO is not empty. If there is data in the TX FIFO, the circuit will transmit it to the smart card if in transmit mode. In T=1 mode, if the LASTTX bit is set and the hardware is configured to transmit the CRC/LRC, the TXEMPTY will not be set until the CRC/LRC is transmitted. In T=0, if the LASTTX bit is set, TXEMPTY will be set after the last word has been successfully transmitted to the smart card. Generates a TXEVNT interrupt upon going empty.						
STXCtl.3	TXUNDR	TX Underrun - (Read only) Asserted when a transmit under-run condition has occurred. An under-run condition is defined as an empty TX FIFO when the last data word has been successfully transmitted to the smart card and the LASTTX bit was not set. No special processing is performed by the hardware if this condition occurs. Cleared when read by firmware. This bit generates a TXERR interrupt.						
STXCtl.2	LASTTX	Last TX Byte - Set by firmware (in both T=0 and T=1) when the last byte in the current message has been written into the transmit FIFO. In T=1 mode, the CRC/LRC will be appended to the message. Should be set after the last byte has been written into the transmit FIFO. Should be cleared by firmware before writing first byte of next message into the transmit FIFO. Used in T=0 to determine when to set TXEMPTY.						
STXCtl.1	TX/RXB	1 = Transmit mode, 0 = Receive mode. Configures the hardware to be receiving from or transmitting to the smart card. Determines which counters should be enabled. This bit should be set to receive mode prior to switching to another interface. Setting and resetting this bit shall initialize the CRC logic. If LASTTX is set, this bit can be reset to RX mode and UART logic will automatically change mode to RX when TX operation is completed (TX_Empty = 1).						
STXCtl.0	BREAKD	Break Detected - (Read only) 1 = A break has been detected on the I/O line indicating that the smart card detected a parity error. Cleared when read. This bit generates a TXERR interrupt.						

**STX Data Register (STXData): 0xFE07 ← 0x00****Table 79: The STXData Register**

MSB				LSB			
STXDAT.7	STXDAT.6	STXDAT.5	STXDAT.4	STXDAT.3	STXDAT.2	STXDAT.1	STXDAT.0
Bit	Function						
STXData.7	Data to be transmitted to smart card. Gets stored in the TX FIFO and then extracted by the hardware and sent to the selected smart card. When the MPU reads this register, the byte pointer is changed to effectively “read out” the data. Thus, two reads will always result in an “empty” FIFO condition. The contents of the FIFO registers are not cleared, but will be overwritten by writes.						
STXData.6							
STXData.5							
STXData.4							
STXData.3							
STXData.2							
STXData.1							
STXData.0							

**SRX Control/Status Register (SRXCtl): 0xFE08 ← 0x00**

This register is used to monitor reception of data from the smart card.

**Table 80: The SRXCtl Register**

MSB				LSB			
BIT9DAT	–	LASTRX	CRCERR	RXFULL	RXEMTY	RXOVRR	PARITYE
Bit	Symbol	Function					
SRXCtl.7	BIT9DAT	Bit 9 Data - When in sync mode and with MODE9/8B set, this bit will contain the data on IO (or SIO) pin that was sampled on the ninth CLK (or SCLK) rising edge. This is used to read data in synchronous 9-bit formats.					
SRXCtl.6	–						
SRXCtl.5	LASTRX	Last RX Byte - User sets this bit during the reception of the last byte. When byte is received and this bit is set, logic checks CRC to match 0x1D0F (T=1 mode) or LRC to match 00h (T=1 mode), otherwise a CRC or LRC error is asserted.					
SRXCtl.4	CRCERR	(Read only) 1 = CRC (or LRC) error has been detected.					
SRXCtl.3	RXFULL	(Read only) RX FIFO is full. Status bit to indicate RX FIFO is full.					
SRXCtl.2	RXEMTY	(Read only) RX FIFO is empty. This is only a status bit and does not generate an RX interrupt.					
SRXCtl.1	RXOVRR	RX Overrun - (Read Only) Asserted when a receive-over-run condition has occurred. An over-run is defined as a byte was received from the smart card when the RX FIFO was full. Invalid data may be in the receive FIFO. Firmware should take appropriate action. Cleared when read. Additional writes to the RX FIFO are discarded when a RXOVRR occurs until the overrun condition is cleared. Will generate an RXERR interrupt.					
SRXCtl.0	PARITYE	Parity Error - (Read only) 1 = The logic detected a parity error on incoming data from the smart card. Cleared when read. Will generate an RXERR interrupt.					

**SRX Data Register (SRXData): 0xFE09 ← 0x00****Table 81: The SRXData Register**

MSB

LSB

SRXDAT.7	SRXDAT.6	SRXDAT.5	SRXDAT.4	SRXDAT.3	SRXDAT.2	SRXDAT.1	SRXDAT.0
----------	----------	----------	----------	----------	----------	----------	----------

Bit	Function
SRXData.7	(Read only) Data received from the smart card. Data received from the smart card gets stored in a FIFO that is read by the firmware.
SRXData.6	
SRXData.5	
SRXData.4	
SRXData.3	
SRXData.2	
SRXData.1	
SRXData.0	



**Smart Card Control Register (SCCtl): 0xFE0A ← 0x21**

This register is used to monitor reception of data from the smart card.

**Table 82: The SCCtl Register**

MSB								LSB	
RSTCRD	–	IO	IOD	C8	C4	CLKLVL	CLKOFF		
Bit	Symbol	Function							
SCCtl.7	RSTCRD	1 = Asserts the RST (set RST = 0) to the smart card interface, 0 = De-assert the RST (set RST = 1) to the smart card interface. Can be used to extend RST to the smart card. Refer to <a href="#">RLength</a> register description. This bit is operational in all modes and can be used to extend RST during activation or perform a “Warm Reset” as required. In auto-sequence mode, this bit should be set = 0 to allow the sequencer to de-assert RST per the <a href="#">RLength</a> parameters. In sync mode (see the <a href="#">SPrtcol</a> register) the sense of this bit is non-inverted, if set = 1, RST = 1, if set = 0, RST = 0. Rlen has no effect on Reset in sync mode.							
SCCtl.6	–								
SCCtl.5	IO	Smart Card I/O. Read is state of I/O signal (Caution, this signal is not synchronized to the MPU clock). In Bypass mode, write value is state of signal on I/O. In sync mode, this bit will contain the value of I/O pin on the latest rising edge of CLK.							
SCCtl.4	IOD	Smart Card I/O Direction control Bypass mode or sync mode. 1 = input (default), 0 = output.							
SCCtl.3	C8	Smart Card C8. When C8 is an output, the value written to this bit will appear on the C8 line. The value read when C8 is an output is the value stored in the register. When C8 is an input, the value read is the value on the C8 pin (Caution, this signal is not synchronized to the MPU clock). When C8 is an input, the value written will be stored in the register but not presented to the C8 pin.							
SCCtl.2	C4	Smart Card C4. When C4 is an output, the value written to this bit will appear on the C4 line. The value read when C4 is an output is the value stored in the register. When C4 is an input, the value read is the value on the C4 pin (Caution, this signal is not synchronized to the MPU clock). When C4 is an input, the value written will be stored in the register but not presented to the C4 pin.							
SCCtl.1	CLKLVL	1 = High, 0 = Low. If CLKOFF is set = 1, the CLK to smart card will be at the logic level indicated by this bit. If in bypass mode, this bit directly controls the state of CLK.							
SCCtl.0	CLKOFF	0 = CLK is enabled. 1 = CLK is not enabled. When asserted, the CLK will stop at the level selected by CLKLVL. This bit has no effect if in bypass mode.							

**External Smart Card Control Register (SCECtl): 0xFE0B ← 0x00**

This register is used to directly set and sample signals of External Smart Card interface. There are three modes of asynchronous operation, an “automatic sequence” mode, and bypass mode. Clock stop per the ISO 7816-3 interface is also supported but firmware must handle the protocol for SIO and SCLK for I<sup>2</sup>C clock stop and start. Control for Reset (to make RST signal), activation control, voltage select, etc. should be handled via the I<sup>2</sup>C interface when using external 73S8010 devices. USR(n) pins shall be used for C4, C8 functions if necessary.

**Table 83: The SCECtl Register**

MSB								LSB	
–	–	SIO	SIOD	–	–	SCLKLVL	SCLKOFF		

Bit	Symbol	Function
SCECtl.7	–	
SCECtl.6	–	
SCECtl.5	SIO	External Smart Card I/O. Bit when read indicates state of pin SIO for SIOD = 1 (Caution, this signal is not synchronized to the MPU clock), when written, sets the state of pin SIO for SIOD = 0. Ignored if not in bypass or sync modes. In sync mode, this bit will contain the value of IO pin on the latest rising edge of SCLK.
SCECtl.4	SIOD	1 = input, 0 = output. External Smart Card I/O Direction control. Ignored if not in bypass or sync modes.
SCECtl.3	–	
SCECtl.2	–	
SCECtl.1	SCLKLVL	Sets the state of SCLK when disabled by SCLKOFF bit. If in bypass mode, this bit directly controls the state of SCLK.
SCECtl.0	SCLKOFF	0 = SCLK enabled, 1 = SCLK disabled. When disabled, SCLK level is determined by SCLKLVL. This bit has no effect if in bypass mode.

**C4/C8 Data Direction Register (SCDIR): 0xFE0C ← 0x00**

This register determines the direction of the internal interface C4/C8 lines. After reset, all signals are tri-stated.

**Table 84: The SCDIR Register**

MSB				LSB			
–	–	–	–	C8D	C4D	–	–

Bit	Symbol	Function
SCDIR.7	–	
SCDIR.6	–	
SCDIR.5	–	
SCDIR.4	–	
SCDIR.3	C8D	1 = input, 0 = output. Smart Card C8 direction.
SCDIR.2	C4D	1 = input, 0 = output. Smart Card C4 direction.
SCDIR.1	–	
SCDIR.0	–	

**Protocol Mode Register (SPrtcol): 0xFE0D ← 0x03**

This register determines the protocol to be use when communicating with the selected smart card. This register should be updated as required when switching between smart card interfaces.

**Table 85: The SPrtcol Register**

MSB				LSB			
SCISYN	MOD9/8B	SCESYN	0	TMODE	CRCEN	CRCMS	RCVATR
Bit	Symbol	Function					
SPrtcol.7	SCISYN	Smart Card Internal Synchronous mode - Configures internal smart card interface for synchronous mode. This mode routes the internal interface buffers for RST, IO, C4, C8 to the <b>SCCtI</b> register bits for direct firmware control. CLK is generated by the ETU counter.					
SPrtcol.6	MOD9/8B	Synchronous 8/9 bit mode select - For sync mode, in protocols with 9-bit words, set this bit. The first eight bits read go into the RX FIFO and the ninth bit read will be stored in the IO (or SIO) data bit of the <b>SRXCtI</b> register.					
SPrtcol.5	SCESYN	Smart Card External Synchronous mode - Configures External Smart Card interface for synchronous mode. This mode routes the external smart card interface buffers for SIO to <b>SCECtI</b> register bits for direct firmware control. SCLK is generated by the ETU counter.					
SPrtcol.4	0	Reserved bit, must always be set to 0.					
SPrtcol.3	TMODE	Protocol mode select - 0: T=0, 1: T=1. Determines which smart card protocol is to be used during message processing.					
SPrtcol.2	CRCEN	CRC Enable – 1 = Enabled, 0 = Disabled. Enables the checking/generation of CRC/LRC while in T=1 mode. Has no effect in T=0 mode. If enabled and a message is being transmitted to the smart card, the CRC/LRC will be inserted into the message stream after the last TX byte is transmitted to the smart card. If enabled, CRC/LRC will be checked on incoming messages and the value made available to the firmware via the CRC LS/MS registers.					
SPrtcol.1	CRCMS	CRC Mode Select – 1 = CRC, 0 = LRC. Determines type of checking algorithm to be used.					
SPrtcol.0	RCVATR	Receive ATR – 1 = Enable ATR timeout, 0 = Disable ATR timeout. Set by firmware after the smart card has been turned on and the hardware is expecting ATR.					

**SC Clock Configuration Register (SCCLK): 0xFE0F ← 0x0C**

This register controls the internal smart card (CLK) clock generation.

**Table 86: The SCCLK Register**

MSB								LSB
–	–	ICLKFS.5	ICLKFS.4	ICLKFS.3	ICLKFS.2	ICLKFS.1	ICLKFS.0	
Bit	Symbol	Function						
SCCLK.7	–							
SCCLK.6	–							
SCCLK.5	ICLKFS.5	Internal Smart Card CLK Frequency Select - Division factor to determine internal smart card CLK frequency. MCLK clock is divided by (register value + 1) to clock the ETU divider, and then by 2 to generate CLK. Default ratio is 13. The programmed value in this register is applied to the divider after this value is written, in such a manner as to produce a glitch-free output, regardless of the selection of active interface. A register value = 0 will default to the same effect as register value = 1.						
SCCLK.4	ICLKFS.4							
SCCLK.3	ICLKFS.3							
SCCLK.2	ICLKFS.2							
SCCLK.1	ICLKFS.1							
SCCLK.0	ICLKFS.0							

**External SC Clock Configuration Register (SCECLK): 0xFE10 ← 0x0C**

This register controls the external smart card (SCLK) clock generation.

**Table 87: The SCECLK Register**

MSB								LSB
–	–	ECLKFS.5	ECLKFS.4	ECLKFS.3	ECLKFS.2	ECLKFS.1	ECLKFS.0	
Bit	Symbol	Function						
SCECLK.7	–							
SCECLK.6	–							
SCECLK.5	ECLKFS.5	External Smart Card CLK Frequency Select - Division factor to determine external smart card CLK frequency. MCLK clock is divided by (register value + 1) to clock the ETU divider, and then by 2 to generate SCLK. Default ratio is 13. The programmed value in this register is applied to the divider after this value is written, in such a manner as to produce a glitch-free output, regardless of the selection of active interface. A register value = 0 will default to the same effect as register value = 1.						
SCECLK.4	ECLKFS.4							
SCECLK.3	ECLKFS.3							
SCECLK.2	ECLKFS.2							
SCECLK.1	ECLKFS.1							
SCECLK.0	ECLKFS.0							

**Parity Control Register (SParCtl): 0xFE11 ← 0x00**

This register provides the ability to configure the parity circuitry on the smart card interface. The settings apply to both integrated smart card interfaces.

**Table 88: The SParCtl Register**

MSB								LSB
	–	DISPAR	BRKGEN	BRKDET	RETRAN	DISCRX	INSPE	FORCPE
Bit	Symbol	Function						
SParCtl.7	–							
SParCtl.6	DISPAR	Disable Parity Check – 1 = disabled, 0 = enabled. If enabled, the UART will check for even parity (the number of 1's including the parity bit is even) on every character. This also applies to the TS during ATR.						
SParCtl.5	BRKGEN	Break Generation Disable – 1 = disabled, 0 = enabled. If enabled, and T=0 protocol, the UART will generate a Break to the smart card if a parity error is detected on a receive character. No Break will be generated if parity checking is disabled. This also applies to TS during ATR.						
SParCtl.4	BRKDET	Break Detection Disable – 1 = disabled, 0 = enabled. If enabled, and T=0 protocol, the UART will detect the generation of a Break by the smart card.						
SParCtl.3	RETRAN	Retransmit Byte – 1 = enabled, 0 = disabled. If enabled and a Break is detected from the smart card (Break Detection must be enabled), the last character will be transmitted again. This bit applies to T=0 protocol.						
SParCtl.2	DISCRX	Discard Received Byte – 1 = enabled, 0 = disabled. If enabled and a parity error is detected (Parity checking must be enabled), the last character received will be discarded. This bit applies to T=0 protocol.						
SParCtl.1	INSPE	Insert Parity Error – 1 = enabled, 0 = disabled. Used for test purposes. If enabled, the UART will insert a parity error in every character transmitted by generating odd parity instead of even parity for the character.						
SParCtl.0	FORCPE	Force Parity Error – 1 = enabled, 0 = disabled. Used for test purposes. If enabled, the UART will generate a parity error on a character received from the smart card.						

**Byte Control Register (SByteCtl): 0xFE12 ← 0x2C**

This register controls the processing of characters and the detection of the TS byte. When receiving, a Break is asserted at 10.5 ETU after the beginning of the start bit. Break from the card is sampled at 11 ETU.

**Table 89: The SByteCtl Register**

MSB						LSB	
	–	DETTS	DIRTS	BRKDUR.1	BRKDUR.0	–	–

Bit	Symbol	Function
SByteCtl.7	–	
SByteCtl.6	DETTS	Detect TS Byte – 1 = Next Byte is TS, 0 = Next byte is not TS. When set, the hardware will treat the next character received as the TS and determine if direct or indirect convention is being used. Direct convention is the default used if firmware does not set this bit prior to transmission of TS by the smart card to the firmware. The hardware will check parity and generate a break as defined by the DISPAR and BRKGEN bits in the parity control register. This bit is cleared by hardware after TS is received. TS is decoded prior to the FIFO and is stored in the receive FIFO.
SByteCtl.5	DIRTS	Direct Mode TS Select – 1 = direct mode, 0 = indirect mode. Set/cleared by hardware when TS is processed indicating either direct/indirect mode of operation. When switching between smart cards, the firmware should write the bit appropriately since this register is not unique to an individual smart card (firmware should keep track of this bit).
SByteCtl.4	BRKDUR.1	Break Duration Select – 00 = 1 ETU, 01 = 1.5 ETU, 10 = 2 ETU, 11 = reserved. Determines the length of a Break signal which is generated when detecting a parity error on a character reception in T=0 mode.
SByteCtl.3	BRKDUR.0	
SByteCtl.2	–	
SByteCtl.1	–	
SByteCtl.0	–	

**FD Control Register (FReg): 0xFE13 ← 0x11**

This register uses the transmission factors F and D to set the ETU (baud) rate. The values in this register are mapped to the ISO 7816 conversion factors as described below. The CLK signal for each interface is created by dividing a high-frequency, intermediate signal (MSCLK) by 2. The ETU baud rate is created by dividing MSCLK by 2 times the Fi/Di ratio specified by the codes below. For example, if Fi = 0001 and Di = 0001, the ratio of Fi/Di is 372/1. Thus the ETU divider is configured to divide by  $2 * 372 = 744$ . The maximum supported F/D ratio is 4096.

**Table 90: The FReg Register**

MSB				LSB			
FVAL.3	FVAL.2	FVAL.1	FVAL.0	DVAL.3	DVAL.2	DVAL.1	DVAL.0

**Table 91: The FReg Bit Functions**

Bit	Symbol	Function
FReg.7	FVAL.3	Refer to the Table 93 above. This value is converted per the table to set the divide ratio used to generate the baud rate (ETU). Default, also used for ATR, is 0001 (Fi = 372). This value is used by the selected interface.
FReg.6	FVAL.2	
FReg.5	FVAL.1	
FReg.4	FVAL.0	
FReg.3	DVAL.3	Refer to Table 93 above. This value is used to set the divide ratio used to generate the smart card CLK. Default, also used for ATR, is 0001 (Di = 1).
FReg.2	DVAL.2	
FReg.1	DVAL.1	
FReg.0	DVAL.0	

**Table 92: Divider Ratios Provided by the ETU Counter**

Fi (code)	0000	0001	0010	0011	0100	0101	0110	0111
Fi (ratio)	372	372	558	744	1116	1488	1860	1860⊕
FCLK max	4	5	6	8	12	16	20	20⊕

Fi (code)	1000	1001	1010	1011	1100	1101	1110	1111
Fi (ratio)	512⊕	512	768	1024	1536	2048	2048⊕	2048⊕
FCLK max	5⊕	5	7.5	10	15	20	20⊕	20⊕

Di (code)	0000	0001	0010	0011	0100	0101	0110	0111
Di (ratio)	1⊕	1	2	4	8	16	32	32⊕

Di (code)	1000	1001	1010	1011	1100	1101	1110	1111
Di (ratio)	12	20	16⊕	16⊕	16⊕	16⊕	16⊕	16⊕

Note: values marked with ⊕ are not included in the ISO definition and arbitrary values have been assigned.

The values given below are used by the ETU divider to create the ETU clock. The entries that are not shaded will result in precise CLK/ETU per ISO requirements. Shaded areas are not precise but are within 1% of the target value.



**Table 93: Divider Values for the ETU Clock**

	Fi code	0000	0001	0010	0011	0100	0101
Di code	F→ D↓	372	372	558	744	1116	1488
0001	1	744	744	1116	1488	2232	2976
0010	2	372	372	558	744	1116	1488
0011	4	186	186	279	372	558	744
0100	8	93	93	138	186	279	372
1000	12	62	62	93	124	186	248
0101	16	47	47	70	93	140	186
1001	20	37	37	56	74	112	149
0110	32	23	23	35	47	70	93

	Fi code	0110	1001	1010	1011	1100	1101
Di code	F→ D↓	1860	512	768	1024	1536	2048
0001	1	3720	1024	1536	2048	3072	4096
0010	2	1860	512	768	1024	1536	2048
0011	4	930	256	384	512	768	1024
0100	8	465	128	192	256	384	512
1000	12	310	85	128	171	256	341
0101	16	233	64	96	128	192	256
1001	20	186	51	77	102	154	205
0110	32	116	32	48	64	96	128

**CRC MS Value Registers (CRCMsB): 0xFE14 ← 0xFF, (CRCLsB): 0xFE15 ← 0xFF****Table 94: The CRCMsB Register**

MSB								LSB
CRC.15	CRC.14	CRC.13	CRC.12	CRC.11	CRC.10	CRC.9	CRC.8	

MSB								LSB
CRC.7	CRC.6	CRC.5	CRC.4	CRC.3	CRC.2	CRC.1	CRC.0	

The 16-bit CRC value forms the TX CRC word in TX mode (write value) and the RX CRC in RX mode (read value). The initial value of CRC to be used when generating a CRC to be transmitted at the end of a message (after the last TX byte is sent) when enabled in T=1 mode. Should be reloaded at the beginning of every message to be transmitted. When using CRC, both CRC registers should be initialized to FF. When using LRC, the CRCLsB value register should be loaded to 00. When receiving a message, the firmware should load this with the initial value and then read this register to get the final value at the end of the message. These registers need to be reloaded for each new message to be received. When in LRC mode, bits (7:0) are used and bits (15:8) are undefined. During LRC/CRC checking and generation, this register is updated with the current value and can be read to aid in debugging. This information will be transmitted to the smart card using the timing specified by the Guard Time register. When checking CRC/LRC on an incoming message (CRC/LRC is checked against the data and CRC/LRC), the firmware reads the final value after the message has been received and determines if an error occurred (= 0x1D0F (CRC) no error, else error; = 0 (LRC) no error, else error). When a message is received, the CRC/LRC is stored in the FIFO. The polynomial used to generate and check CRC is  $x^{16} + x^{12} + x^5 + 1$ . When in indirect convention, the CRC is generated prior to the conversion into indirect convention. When in indirect convention, the CRC is checked after the conversion out of indirect convention. For a given message, the CRC generated (and readable from this register) will be the same whether indirect or direct convention is used to transmit the data to the smart card. The CRCLsB / CRCMsB registers will be updated with CRC/LRC whenever bits are being received or transmitted from/to the smart card (even if CRCEN is not set and in mode T1). They are available to the firmware to use if desired.

**Block Guard Time Register (BGT): 0xFE16 ← 0x10**

This register contains the Extra Guard Time Value (EGT) most-significant bit. The Extra Guard Time indicates the minimum time between the leading edges of the start bit of consecutive characters. The delay depends on the T=0/T=1 mode. Used in transmit mode. This register also contains the Block Guard Time (BGT) value. Block Guard Time is the minimum time between the leading edge of the start bit of the last character received and the leading edge of the start bit of the first character transmitted. This should not be set less than the character length. The transmission of the first character will be held off until BGT has elapsed regardless of the TX data and TX/RX control bit timing.

**Table 95: The BGT Register**

MSB				LSB			
EGT.8	–	–	BGT.4	BGT.3	BGT.1	BGT.2	BGT.0

Bit	Symbol	Function
BGT.7	EGT.8	Most-significant bit for 9-bit EGT timer. See the <a href="#">EGT</a> register.
BGT.6	–	
BGT.5	–	
BGT.4	BGT.4	Time in ETUs between the start bit of the last received character to start bit of the first character transmitted to the smart card. Default value is 22.
BGT.3	BGT.3	
BGT.2	BGT.2	
BGT.1	BGT.1	
BGT.0	BGT.0	

**Extra Guard Time Register (EGT): 0xFE17 ← 0x0C**

This register contains the Extra Guard Time Value (EGT) least-significant byte. The Extra Guard Time indicates the minimum time between the leading edges of the start bit of consecutive characters. The delay depends on the T=0/T=1 mode. Used in transmit mode.

**Table 96: The EGT Register**

MSB							LSB
EGT.7	EGT.6	EGT.5	EGT.4	EGT.3	EGT.1	EGT.2	EGT.0

Bit	Function
EGT.7	Time in ETUs between start bits of consecutive characters. In T=0 mode, the minimum is 1. In T=0, the leading edge of the next start bit may be delayed if there is a break detected from the smart card. Default value is 12. In T=0 mode, regardless of the value loaded, the minimum value is 12, and for T=1 mode, the minimum value is 11.
EGT.6	
EGT.5	
EGT.4	
EGT.3	
EGT.2	
EGT.1	
EGT.0	

**Block Wait Time Registers (BWTB0): 0xFE1B ← 0x00, (BWTB1): 0xFE1A ← 0x00, (BWTB2): 0xFE19 ← 0x00, (BWTB3): 0xFE18 ← 0x00**

These registers are used to set the Block Waiting Time(27:0) (BWT). All of these parameters define the maximum time the 73S1210F will have to wait for a character from the smart card. These registers serve a dual purpose. When T=1, these registers are used to set up the block wait time. The block wait time defines the time in ETUs between the beginning of the last character sent to smart card and the start bit of the first character received from smart card. It can be used to detect an unresponsive card and should be loaded by firmware prior to writing the last TX byte. When T=0, these registers are used to set up the work wait time. The work wait time is defined as the time between the leading edge of two consecutive characters being sent to or from the card. If a timeout occurs, an interrupt is generated to the firmware. The firmware can then take appropriate action. A Wait Time Extension (WTX) is supported with the 28-bit BWT.

**Table 97: The BWTB0 Register**

MSB				LSB			
BWT.7	BWT.6	BWT.5	BWT.4	BWT.3	BWT.1	BWT.2	BWT.0

**Table 98: The BWTB1 Register**

MSB				LSB			
BWT.15	BWT.14	BWT.13	BWT.12	BWT.11	BWT.10	BWT.9	BWT.8

**Table 99: The BWTB2 Register**

MSB				LSB			
BWT.23	BWT.22	BWT.21	BWT.20	BWT.19	BWT.18	BWT.17	BWT.16

**Table 100: The BWTB3 Register**

MSB				LSB			
–	–	–	–	BWT.27	BWT.26	BWT.25	BWT.24

**Character Wait Time Registers (CWTB0): 0xFE1D ← 0x00, (CWTB1): 0xFE1C ← 0x00**

These registers are used to hold the Character Wait Time(15:0) (CWT) or Initial Waiting Time(15:0) (IWT) depending on the situation. Both the IWT and the CWT measure the time in ETUs between the leading edge of the start of the current character received from the smart card and the leading edge of the start of the next character received from the smart card. The only difference is the mode in which the card is operating. When T=1 these registers are used to configure the CWT and these registers configure the IWT when the ATR is being received. These registers should be loaded prior to receiving characters from the smart card. Firmware must manage which time is stored in the register. If a timeout occurs, an interrupt is generated to the firmware. The firmware can then take appropriate action.

**Table 101: The CWTB0 Register**

MSB				LSB			
CWT.7	CWT.6	CWT.5	CWT.4	CWT.3	CWT.1	CWT.2	CWT.0

**Table 102: The CWTB1 Register**

MSB				LSB			
CWT.15	CWT.14	CWT.13	CWT.12	CWT.11	CWT.10	CWT.9	CWT.8

**ATR Timeout Registers (ATRLsB): 0xFE20 ← 0x00, (ATRMsb): 0xFE1F ← 0x00**

These registers form the ATR timeout (ATRTO [15:0]) parameter. Time in ETU between the leading edge of the first character and leading edge of the last character of the ATR response. Timer is enabled when the RCVATR is set and starts when leading edge of the first start bit is received and disabled when the RCVATR is cleared. An ATR timeout is generated if this time is exceeded.

**Table 103: The ATRLsB Register**

MSB							LSB
ATRTO.7	ATRTO.6	ATRTO.5	ATRTO.4	ATRTO.3	ATRTO.1	ATRTO.2	ATRTO.0

**Table 104: The ATRMsB Register**

MSB							LSB
ATRTO.15	ATRTO.14	ATRTO.13	ATRTO.12	ATRTO.11	ATRTO.10	ATRTO.9	ATRTO.8

**TS Timeout Register (STSTO): 0xFE21 ← 0x00**

The TS timeout is the time in ETU between the de-assertion of smart card reset and the leading edge of the TS character in the ATR (when DETTS is set). The timer is started when smart card reset is de-asserted. An ATR timeout is generated if this time is exceeded (MUTE card).

**Table 105: The STSTO Register**

MSB							LSB
TST0.7	TST0.6	TST0.5	TST0.4	TST0.3	TST0.1	TST0.2	TST0.0

**Reset Time Register (RLength): 0xFE22 ← 0x70**

Time in ETUs that the hardware delays the de-assertion of RST. If set to 0 and RSTCRD = 0, the hardware adds no extra delay and the hardware will release RST after VCCOK is asserted during power-up. If set to 1, it will delay the release of RST by the time in this register. When the firmware sets the RSTCRD bit, the hardware will assert reset (RST = 0 on pin). When firmware clears the bit, the hardware will release RST after the delay specified in RLen. If firmware sets the RSTCRD bit prior to instructing the power to be applied to the smart card, the hardware will not release RST after power-up until RLen after the firmware clears the RSTCRD bit. This provides a means to power up the smart card and hold it in reset until the firmware wants to release the RST to the selected smart card. Works with the selected smart card interface.

**Table 106: The RLength Register**

MSB							LSB
RLen.7	RLen.6	RLen.5	RLen.4	RLen.3	RLen.1	RLen.2	RLen.0

Shaded locations indicate functions that are not provided in the synchronous mode.

**Table 107: Smart Card SFR Table**

Name	Address	b7	b6	b5	b4	b3	b2	b1	b0
SCSel	FE00					SelSC(1:0)		BYPASS	
SCInt	FE01	WAITTO/ RLIEN	CRDEVT	VCCTMR	RXDAVI	TXEVNT	TXSENT	TXERR	RXERR
SCIE	FE02	WTOI/ RLIEN	CDEVNT	VTMREN	RXDAEN	TXEVEN	TXSNTEN	TXERR	RXERR
VccCtl	FE03	VCCSEL.1	VCCSEL.0	VDDFLT	RDYST	VCCOK			SCPWRDN
VCCTmr	FE04	OFFTMR(3:0)			VCCTMR(3:0)				
CRDCtl	FE05	DEBOUN	CDETEN			DETPOL	PUENB	PDEN	CARDIN
STXCtl	FE06	I2CMODE		TXFULL	TXEMTY	TXUNDR	LASTTX	TX/RXB	BREAKD
STXData	FE07	TXDATA(7:0)							
SRXCtl	FE08	BIT9DAT		LASTRX	CRCCERR	RXFULL	RXEMTY	RXOVRR	PARITYE
SRXData	FE09	RXDATA(7:0)							
SCCtl	FE0A	RSTCRD		IO	IOD	C8	C4	CLKLVL	CLKOFF
SCECtl	FE0B			SIO	SIOD			SCLKLVL	SCLKOFF
SCDIR	FE0C					C8D	C4D		
SPrtcol	FE0D	SCISYN	MOD9/8B	SCESYN	0	TMODE	CRCCEN	CRCMS	RCVATR
SCCLK	FE0F			ICLKFS(5:0)					
SCECLK	FE10			ECLKFS(5:0)					
SParCtl	FE11		DISPAR	BRKGEN	BRKDET	RTRAN	DISCRX	INSPE	FORCPE
SByteCtl	FE12		DETTS	DIRTS	BRKDUR (1:0)				
FReg	FE13	FVAL(3:0)				DVAL (3:0)			
CRCMsB	FE14	CRC(15:8)							
CRCLsB	FE15	CRC(7:0)							
BGT	FE16	EGT8				BGT(4:0)			
EGT	FE17	EGT(7:0)							
BWTB3	FE18					BWT(27:24)			
BWTB2	FE19	BWT(23:16)							
BWTB1	FE1A	BWT(15:8)							
BWTB0	FE1B	BWT(7:0)							
CWTB1	FE1C	CWT(15:8)							
CWTB0	FE1D	CWT(7:0)							
ATRMsb	FE1F	ATRTO(15:8)							
ATRLsB	FE20	ATRTO(7:0)							
STSTO	FE21	TSTO(7:0)							
RLength	FE22	RLen(7:0)							

### 1.7.16 VDD Fault Detect Function

The 73S1210F contains a circuit to detect a low-voltage condition on the supply voltage  $V_{DD}$ . If enabled, it will deactivate the active internal smart card interface when  $V_{DD}$  falls below the  $V_{DD}$  Fault threshold. The register configures the  $V_{DD}$  Fault threshold for the nominal default of 2.3V\* or a user selectable threshold. The user's code may load a different value using the FOVRVDDF bit = 1 after the power-up cycle has completed.

#### VDDFault Control Register (VDDFCtl): 0xFFD4 ← 0x00

**Table 108: The VDDFCtl Register**

Bit	Symbol	Function
VDDFCtl.7	–	
VDDFCtl.6	FOVRVDDF	Setting this bit high will allow the VDDFLT(2:0) bits set in this register to control the VDDFault threshold. When this bit is set low, the VDDFault threshold will be set to the factory default setting of 2.3V*.
VDDFCtl.5	VDDFLTEN	Set = 1 will disable VDD Fault operation.
VDDFCtl.4	–	
VDDFCtl.3	–	
VDDFCtl.2	VDDFTH.2	VDD Fault Threshold.
VDDFCtl.1	VDDFTH.1	Bit Value(2:0)    VDDFault Voltage
VDDFCtl.0	VDDFTH.0	000            2.3 (nominal default)
		001            2.4
		010            2.5
		011            2.6
		100            2.7
		101            2.8
		110            2.9
		111            3.0

\* Note: The  $V_{DD}$  Fault factory default can be set to any threshold as defined by bits VDDFTH(2:0). The 73S1210F has the capability to burn fuses at the factory to set the factory default to any of these voltages. Contact Teridian for further details.

## 2 Typical Application Schematic

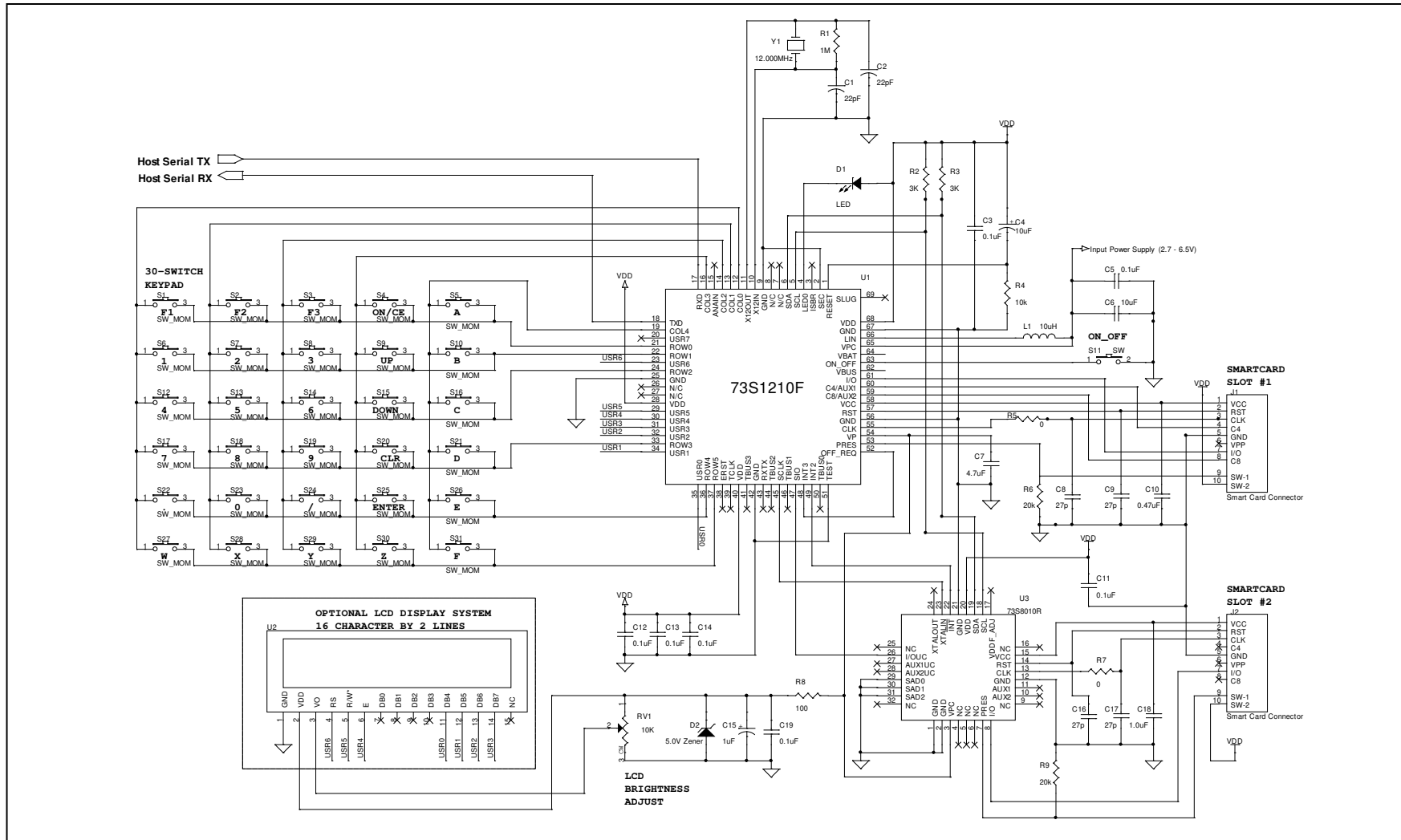


Figure 25: 73S1210F Typical Application Schematic



### 3 Electrical Specification

#### 3.1 Absolute Maximum Ratings

Operation outside these rating limits may cause permanent damage to the device. The smart card interface pins are protected against short circuits to  $V_{CC}$ , ground, and each other.

Parameter	Rating
DC Supply voltage, $V_{DD}$	-0.5 to 4.0 VDC
Supply Voltage $V_{PC}$	-0.5 to 6.6 VDC
Supply Voltage $V_{BUS}$	-0.5 to 6.6 VDC
Supply Voltage $V_{BAT}$	-0.5 to 6.6 VDC
Storage Temperature	-60 to 150°C
Pin Voltage (except card interface)	-0.3 to $(V_{DD}+0.5)$ VDC
Pin Voltage (card interface)	-0.3 to $(V_{CC}+0.5)$ VDC
ESD tolerance (except card interface)	+/- 2KV
ESD tolerance (card interface)	+/- 7KV
Pin Current	$\pm 200$ mA

Note: ESD testing on smart card pins is HBM condition, 3 pulses, each polarity referenced to ground.

Note: Smart Card pins are protected against shorts between any combinations of Smart Card pins.

#### 3.2 Recommended Operating Conditions

Unless otherwise noted all specifications are valid over these temperatures and supply voltage ranges:

Parameter	Rating
Supply Voltage $V_{PC}$	2.7 to 6.5 VDC
Supply Voltage $V_{BUS}$	4.4 to 5.5 VDC
Supply Voltage $V_{BAT}$	4.0 to 6.5 VDC
Ambient Operating Temperature ( $T_a$ )	-40°C to +85°C

### 3.3 Digital IO Characteristics

These requirements pertain to digital I/O pin types with consideration of the specific pin function and configuration. The LED(1:0) pins have pull-ups that may be enabled. The Row pins have 100kΩ pull-ups.

Symbol	Parameter	Conditions	Min.	Typ.	Max.	Unit
Voh	Output level, high	I <sub>oh</sub> = -2mA	0.8 * V <sub>DD</sub>		V <sub>DD</sub>	V
		OFF_REQ pin - I <sub>OH</sub> = -1mA	V <sub>DD</sub> - 0.45			V
Vol	Output level, low	I <sub>ol</sub> = 2mA	0		0.3	V
		OFF_REQ pin - I <sub>ol</sub> = 2mA			0.45	V
Vih	Input voltage, high	2.7v < VDD < 3.6v	1.8		V <sub>DD</sub> + 0.3	V
Vil	Input voltage, low	2.7v < VDD < 3.6v	-0.3		0.6	V
		RESET, ON_OFF, PRES pins	-0.3		0.8	V
Ileak	Leakage current	0 < V <sub>in</sub> < VDD All output modes disabled, pull-up/downs disabled	-5		5	μA
Ipu	Pull-up current	If provided and enabled, V <sub>out</sub> < 0.1v	-5			μA
Ipd	Pull-down current	If provided and enabled, V <sub>out</sub> > VDD - 0.1v			5	μA

Symbol	Parameter	Conditions	Min.	Typ.	Max.	Unit
Iled	LED drive current	V <sub>out</sub> = 1.3V, 2.7v < VDD < 3.6v		2 4 10		mA
Iolkrow	Keypad row output low current	0.0v < Voh < 0.1v when pull-up R is enabled		40	100	μA
Iolkcol	Keypad column output high current	0.0v < Voh < 0.1v when col. is pulled low		1.5	3	mA

### 3.4 Oscillator Interface Requirements

Symbol	Parameter	Condition	Min	Typ.	Max	Unit
<b>High-Frequency Oscillator (Xin) Parameters. Xin Is Used As Input For External Clock For Test Purposes Only. A Resistor Connecting x12in To x12out Is Required, Value = 1mΩ.</b>						
VILX12IN	Input Low Voltage – X12IN		-0.3	1.5	0.3*VDD	V
VIHX12IN	Input High Voltage – X12IN		0.7*VDD	1.6	Vdd+.0.3	V
IILXTAL	Input Current -X12IN	GND < Vin < Vdd	-10		10	μA
Fxtal	Crystal resonant frequency	Fundamental mode	6		12	MHz

### 3.5 DC Characteristics: Analog Input

Symbol	Parameter	Condition	Min	Typ.	Max	Unit
V <sub>TH</sub> TOL	Voltage Threshold Tolerance	Selected Threshold Value	-3%		+3%	V

### 3.6 Smart Card Interface Requirements

Symbol	Parameter	Condition	Min	Typ.	Max	Unit
<b>Card Power Supply (V<sub>CC</sub>) Regulator</b>						
<b>General conditions, -40°C &lt; T &lt; 85°C, 4.75V &lt; V<sub>PC</sub> &lt; 6.0V, 2.7V &lt; V<sub>DD</sub> &lt; 3.6V</b>						
V <sub>CC</sub>	Card supply Voltage including ripple and noise	Inactive mode	-0.1		0.1	V
		Inactive mode, I <sub>CC</sub> = 1mA	-0.1		0.4	V
		Active mode; I <sub>CC</sub> < 65mA; 5V	4.65		5.25	V
		Active mode; I <sub>CC</sub> < 65mA; 3V	2.85		3.15	V
		Active mode; I <sub>CC</sub> < 40mA; 1.8V	1.68		1.92	V
		Active mode; single pulse of 100mA for 2μs; 5V, fixed load = 25mA	4.6		5.25	V
		Active mode; single pulse of 100mA for 2μs; 3V, fixed load = 25mA	2.76		3.15	V
		Active mode; current pulses of 40nAs with peak  I <sub>CC</sub>   < 200mA, t < 400ns; 5V	4.6		5.25	V
		Active mode; current pulses of 40nAs with peak  I <sub>CC</sub>   < 200mA, t < 400ns; 3V	2.7		3.15	V
		Active mode; current pulses of 20nAs with peak  I <sub>CC</sub>   < 100mA, t < 400ns; 1.8V	1.62		1.92	V
V <sub>CCrip</sub>	V <sub>CC</sub> Ripple	f <sub>RIPPLE</sub> = 20kHz – 200MHz			350	mV
I <sub>CCmax</sub>	Card supply output current	Static load current, V <sub>CC</sub> > 1.65			40	mA
		Static load current, V <sub>CC</sub> > 4.6V or 2.7V as selected			65	mA
I <sub>CCF</sub>	I <sub>CC</sub> fault current	Class A, B (5V and 3V)	100		180	mA
		Class C (1.8V)	60		130	
I <sub>sc</sub>	Maximum current prior to shut-down	Load current limit prior to V <sub>CC</sub> shut-down	80		150	mA.
		Load current limit prior to V <sub>CC</sub> shut-down for V <sub>CC</sub> = 1.8V	60		130	mA
V <sub>SR</sub>	V <sub>CC</sub> slew rate, rise	Rise rate on activate C = 0.47μF	0.12	.30	0.50	V/μs
V <sub>SF</sub>	V <sub>CC</sub> slew rate, fall	Fall rate on deactivate, C = 0.47μF	0.15	.30	1.20	V/μs
V <sub>rdy</sub>	V <sub>CC</sub> ready voltage (V <sub>CCOK</sub> = 1)	5V operation, V <sub>CC</sub> rising	4.6			V
		3V operation, V <sub>CC</sub> rising	2.75			V
		1.8V operation, V <sub>CC</sub> rising	1.65			V

Symbol	Parameter	Condition	Min	Typ.	Max	Unit
<b>Interface Requirements – Data Signals: I/O, AUX1 and AUX2</b>						
V <sub>OH</sub>	Output level, high	I <sub>OH</sub> = 0	0.9 * V <sub>CC</sub>		V <sub>CC</sub> +0.1	V
		I <sub>OH</sub> = -40μA	0.75 V <sub>CC</sub>		V <sub>CC</sub> +0.1	V
V <sub>OL</sub>	Output level, low	I <sub>OL</sub> = 1mA			0.15 * V <sub>CC</sub>	V
V <sub>IH</sub>	Input level, high		0.6 * V <sub>CC</sub>		V <sub>CC</sub> +0.30	V
V <sub>IL</sub>	Input level, low		-0.15		0.2 * V <sub>CC</sub>	V
V <sub>INACT</sub>	Output voltage when outside of session	I <sub>OL</sub> = 0			0.1	V
		I <sub>OL</sub> = 1mA			0.3	V
I <sub>LEAK</sub>	Input leakage	V <sub>IH</sub> = V <sub>CC</sub>			10	μA
I <sub>IL</sub>	Input current, low	V <sub>IL</sub> = 0			0.65	mA
I <sub>IL</sub>	Input current, low	V <sub>IL</sub> = 0			0.7	mA
I <sub>SHORTL</sub>	Short circuit output current	For output low, shorted to V <sub>CC</sub> through 33Ω			15	mA
I <sub>SHORTH</sub>	Short circuit output current	For output high, shorted to ground through 33Ω			15	mA
t <sub>R</sub> , t <sub>F</sub>	Output rise time, fall times	For I/O, AUX1, AUX2, C <sub>L</sub> = 80pF, 10% to 90%. For I/OUC, AUX1UC, AUX2UC, C <sub>L</sub> = 50Pf, 10% to 90%.			100	ns
t <sub>IR</sub> , t <sub>IF</sub>	Input rise, fall times				1	μs
R <sub>PU</sub>	Internal pull-up resistor	Output stable for >200ns	8	11	14	kΩ
FD <sub>MAX</sub>	Maximum data rate				1	MHz
<b>Reset and Clock for card interface, RST, CLK</b>						
V <sub>OH</sub>	Output level, high	I <sub>OH</sub> = -200μA	0.9 * V <sub>CC</sub>		V <sub>CC</sub>	V
V <sub>OL</sub>	Output level, low	I <sub>OL</sub> = 200μA	0		0.15 * V <sub>CC</sub>	V
V <sub>INACT</sub>	Output voltage when outside of session	I <sub>OL</sub> = 0			0.1	V
		I <sub>OL</sub> = 1mA			0.3	V
I <sub>RST_LIM</sub>	Output current limit, RST				30	
I <sub>CLK_LIM</sub>	Output current limit, CLK				70	mA
t <sub>R</sub> , t <sub>F</sub>	Output rise time, fall time	C <sub>L</sub> = 35pF for CLK, 10% to 90%			8	ns
		C <sub>L</sub> = 200pF for RST, 10% to 90%			100	ns
δ	Duty cycle for CLK	C <sub>L</sub> = 35pF, F <sub>CLK</sub> ≤ 20MHz, CLKIN duty cycle is 48% to 52%.	45		55	%

### 3.7 DC Characteristics

Symbol	Parameter	Condition	Min	Typ.	Max	Unit
$I_{PC}$	Supply Current @ $V_{PC} = 2.7V$ ( $V_{BUS}$ and $V_{BAT}$ unconnected)	CPU clock @ 24MHz	44	55	66	mA
		CPU clock @ 12MHz	31	38	46	mA
		CPU clock @ 6MHz	23	29	35	mA
		CPU clock @ 3.69MHz	20	25	30	mA
	Supply Current @ $V_{PC} = 3.3V$ ( $V_{BUS}$ and $V_{BAT}$ unconnected)	CPU clock @ 24MHz	34	43	51	mA
		CPU clock @ 12MHz	24	30	36	mA
		CPU clock @ 6MHz	18	22	27	mA
		CPU clock @ 3.69MHz	16	19	23	mA
	Supply Current @ $V_{PC} = 5.0V$ ( $V_{BUS}$ and $V_{BAT}$ unconnected)	CPU clock @ 24MHz	20	25	30	mA
		CPU clock @ 12MHz	14	18	21	mA
		CPU clock @ 6MHz	11	13	16	mA
		CPU clock @ 3.69MHz	9	12	14	mA
$I_{VBUS}$	Supply Current @ $V_{VBUS} = 4.4V$	CPU clock @ 24MHz	16	20	24	mA
		CPU clock @ 12MHz	11	14	17	mA
		CPU clock @ 6MHz	8	10	13	mA
		CPU clock @ 3.69MHz	7	9	11	mA
	Supply Current @ $V_{VBUS} = 5.0V$	CPU clock @ 24MHz	16	19	23	mA
		CPU clock @ 12MHz	11	14	17	mA
		CPU clock @ 6MHz	8	10	13	mA
		CPU clock @ 3.69MHz	7	9	11	mA
	Supply Current @ $V_{VBUS} = 5.5V$	CPU clock @ 24MHz	16	20	23	mA
		CPU clock @ 12MHz	11	14	17	mA
		CPU clock @ 6MHz	8	11	13	mA
		CPU clock @ 3.69MHz	7	9	11	mA
$I_{VBAT}$	Supply Current @ $V_{VBAT} = 4.0V$ ( $V_{BUS} = 0V$ )	CPU clock @ 24MHz	28	34	41	mA
		CPU clock @ 12MHz	19	24	28	mA
		CPU clock @ 6MHz	14	18	21	mA
		CPU clock @ 3.69MHz	12	15	19	mA
	Supply Current @ $V_{VBAT} = 5.0V$ ( $V_{BUS} = 0V$ )	CPU clock @ 24MHz	20	26	31	mA
		CPU clock @ 12MHz	14	18	21	mA
		CPU clock @ 6MHz	11	13	16	mA
		CPU clock @ 3.69MHz	9	12	14	mA
	Supply Current @ $V_{VBAT} = 6.5V$ ( $V_{BUS} = 0V$ )	CPU clock @ 24MHz	16	20	24	mA
		CPU clock @ 12MHz	11	14	17	mA
		CPU clock @ 6MHz	8	10	13	mA
		CPU clock @ 3.69MHz	7	9	11	mA
$V_{DD}^*$	$V_{DD}$ Supply Voltage	2.7V < $V_{PC}$ < 6.5V, $I_{VDD} < 40mA$ .	3.0	3.3	3.6	V

I <sub>DD_IN</sub>	Supply Current – pins 28 + 40 (internal consumption – digital core)	CPU clock @ 24MHz		29	33.5	mA
		CPU clock @ 12MHz		21	24	mA
		CPU clock @ 6MHz		15.5	18	mA
		CPU clock @ 3.69MHz		13.5	15.5	mA
		Power down (-40° to 85°C)		8	50	μA
		Power down (25°C)		6	15	μA
I <sub>DD_OUT</sub>	Supply Current – pin 68 (available to external circuitry)	Circuit ON			20	mA
I <sub>VBUS</sub>	Supply Current from V <sub>BUS</sub>	V <sub>CC</sub> off, I <sub>DDINTERNAL</sub> < 20μA		0.2	0.4	mA
I <sub>VBAT</sub> I <sub>VPC</sub>	Supply Current from V <sub>BAT</sub> or V <sub>PC</sub>	Circuit OFF		0.01	1	μA
VBUS <sub>ON</sub>	V <sub>BUS</sub> detection threshold			3.5		V
VBUS <sub>IDIS</sub>	V <sub>BUS</sub> discharge current			50		μA
<b>External Capacitor Values</b>						
C <sub>VPC</sub>	External filter capacitor for V <sub>PC</sub>		8.0	10.0	12.0	μF
C <sub>VP</sub>	External filter capacitor for V <sub>P</sub>		2.0	4.7	10.0	μF
C <sub>VDD</sub> *	External filter capacitors for V <sub>DD</sub>		0.2		1.0	μF
C <sub>VCC</sub>	External filter capacitor for V <sub>CC</sub>	C <sub>VCC</sub> should be ceramic with low ESR (<100MΩ).	0.2	0.47	1.0	μF

\*Note: Recommend on 0.1μF for each V<sub>DD</sub> pin.

### 3.8 Current Fault Detection Circuits

Symbol	Parameter	Condition	Min	Typ.	Max	Unit
I <sub>VPmax</sub>	V <sub>P</sub> over current fault				150	mA
I <sub>DDmax</sub>	VDD over-current limit		40		100	mA
I <sub>CCF</sub>	Card overcurrent fault		80		150	mA
I <sub>CCF1P8</sub>	Card overcurrent fault	V <sub>CC</sub> = 1.8V	60		130	mA

### 4 Equivalent Circuits

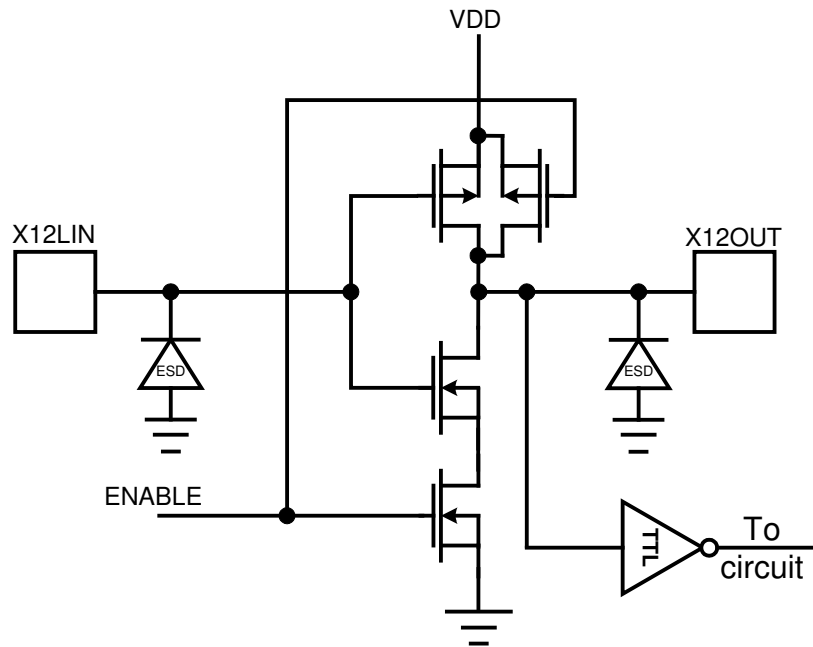


Figure 26: 12 MHz Oscillator Circuit

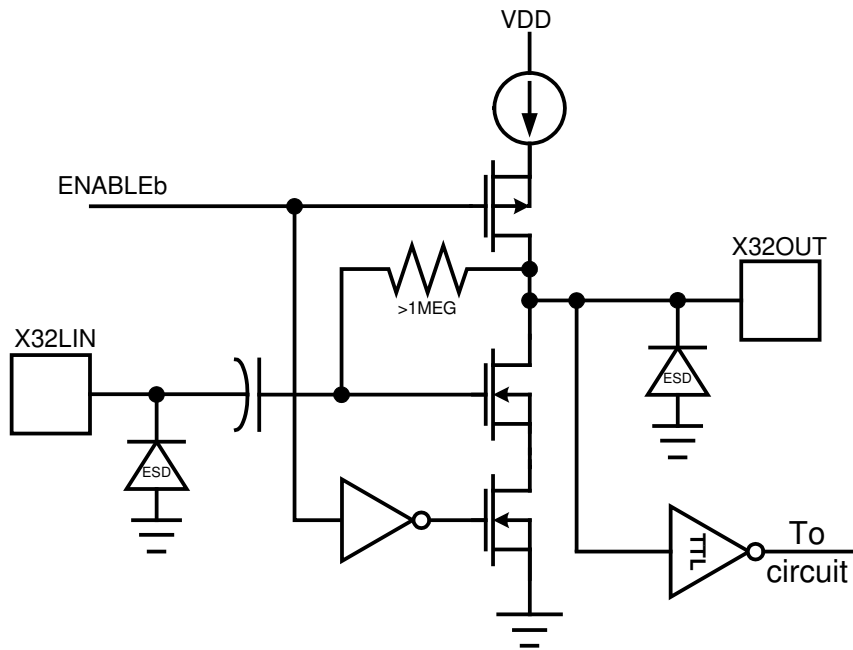


Figure 27: 32KHz Oscillator Circuit



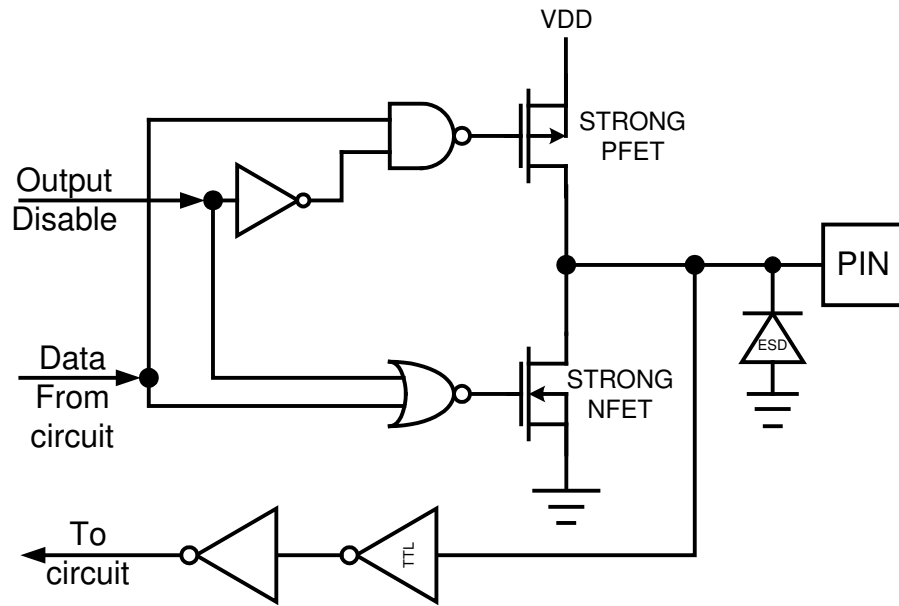


Figure 28: Digital I/O Circuit

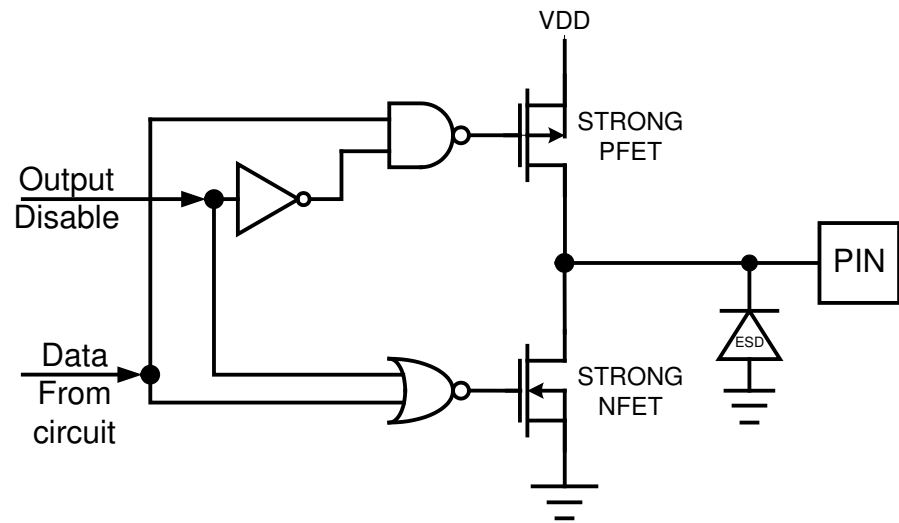
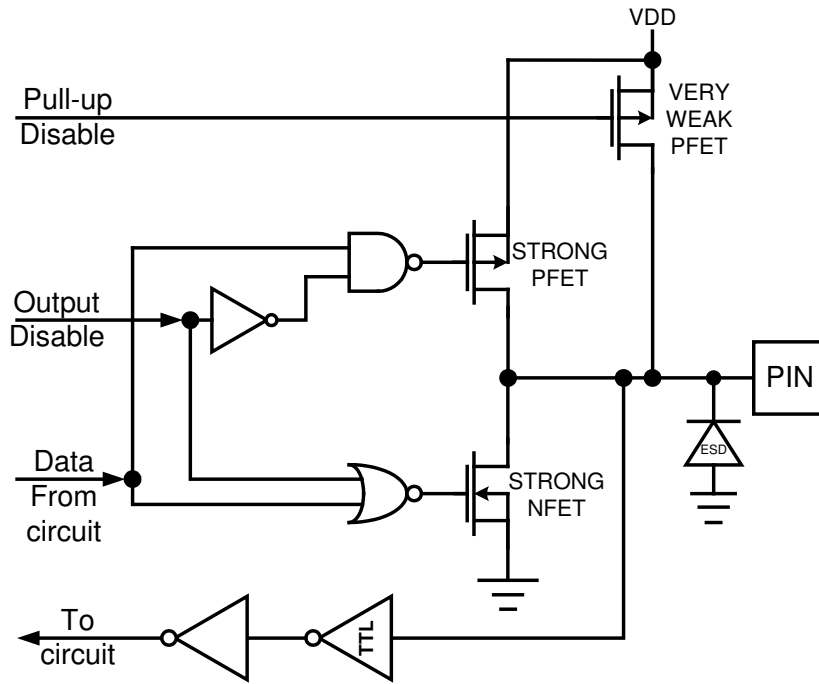
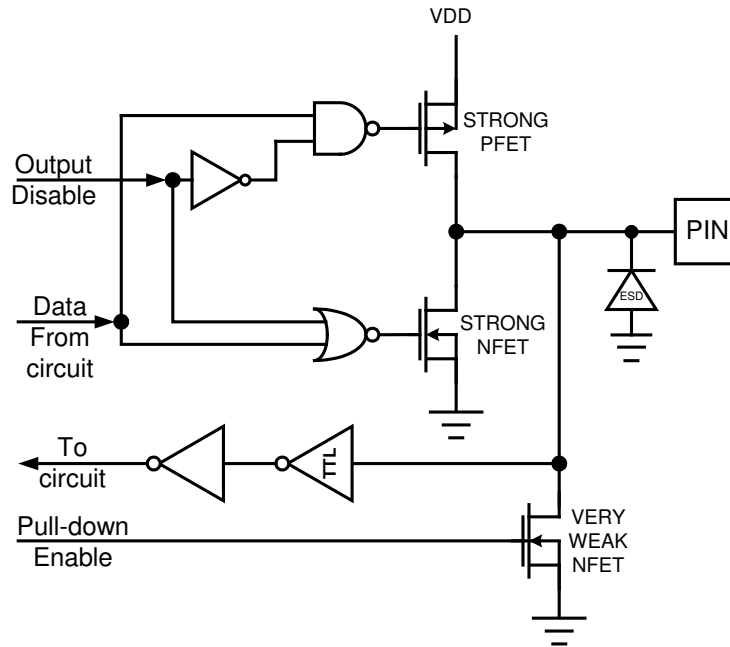


Figure 29: Digital Output Circuit



**Figure 30: Digital I/O with Pull Up Circuit**



**Figure 31: Digital I/O with Pull Down Circuit**

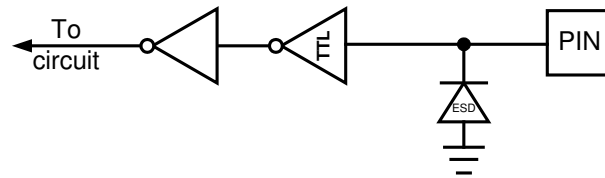


Figure 32: Digital Input Circuit

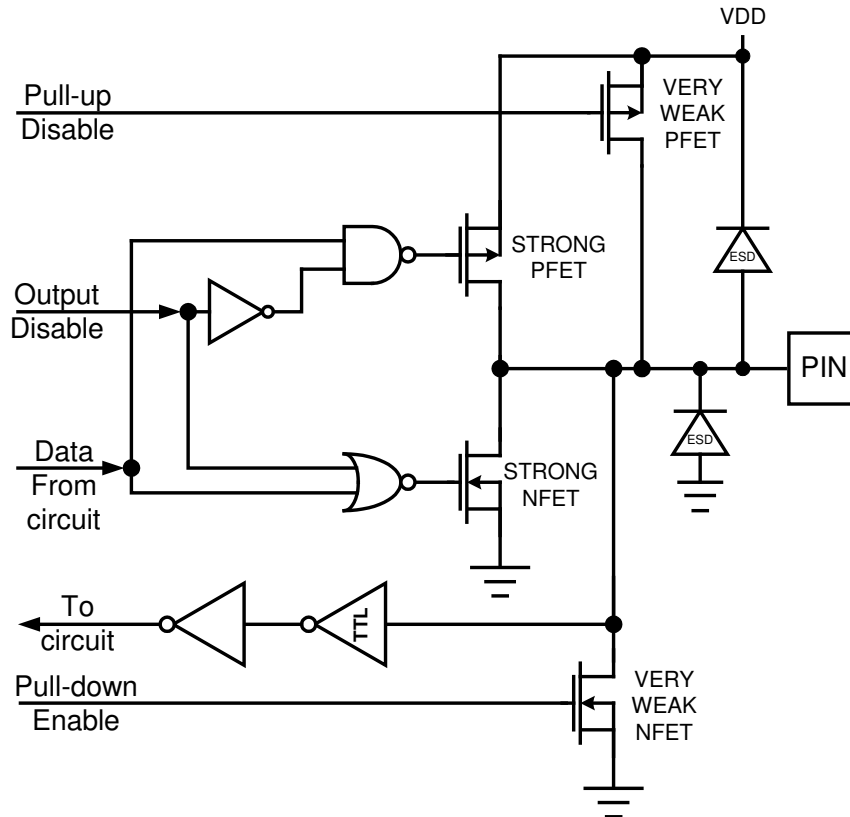


Figure 33: OFF\_REQ Interface Circuit

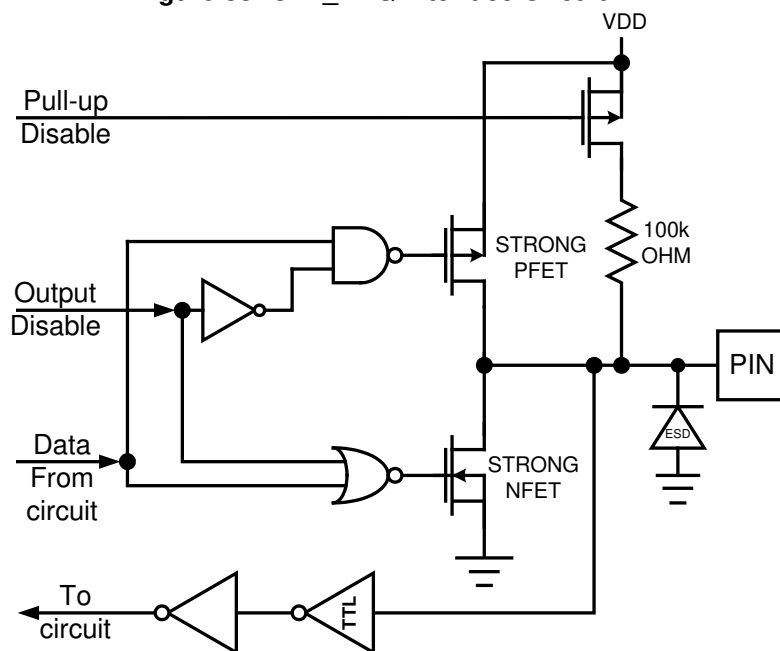


Figure 34: Keypad Row Circuit

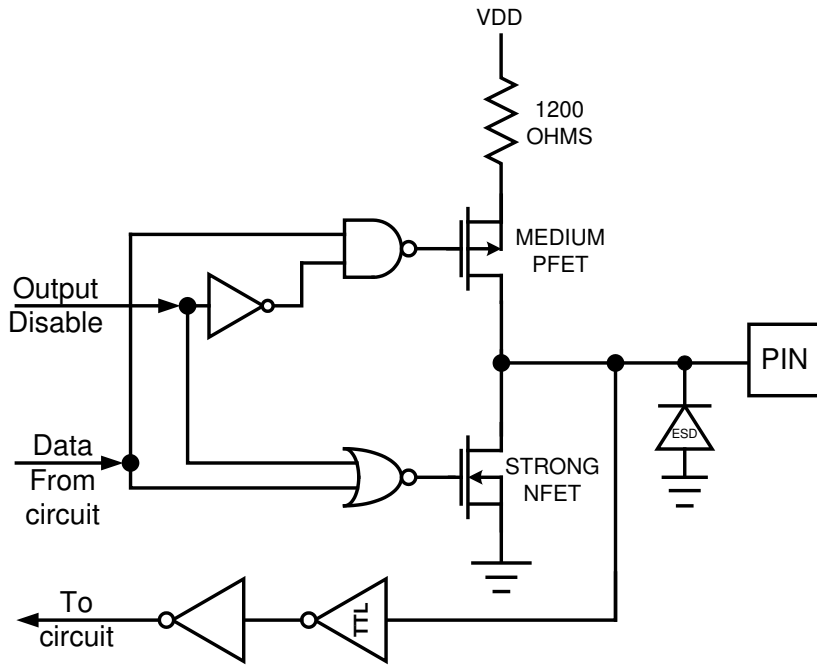


Figure 35: Keypad Column Circuit

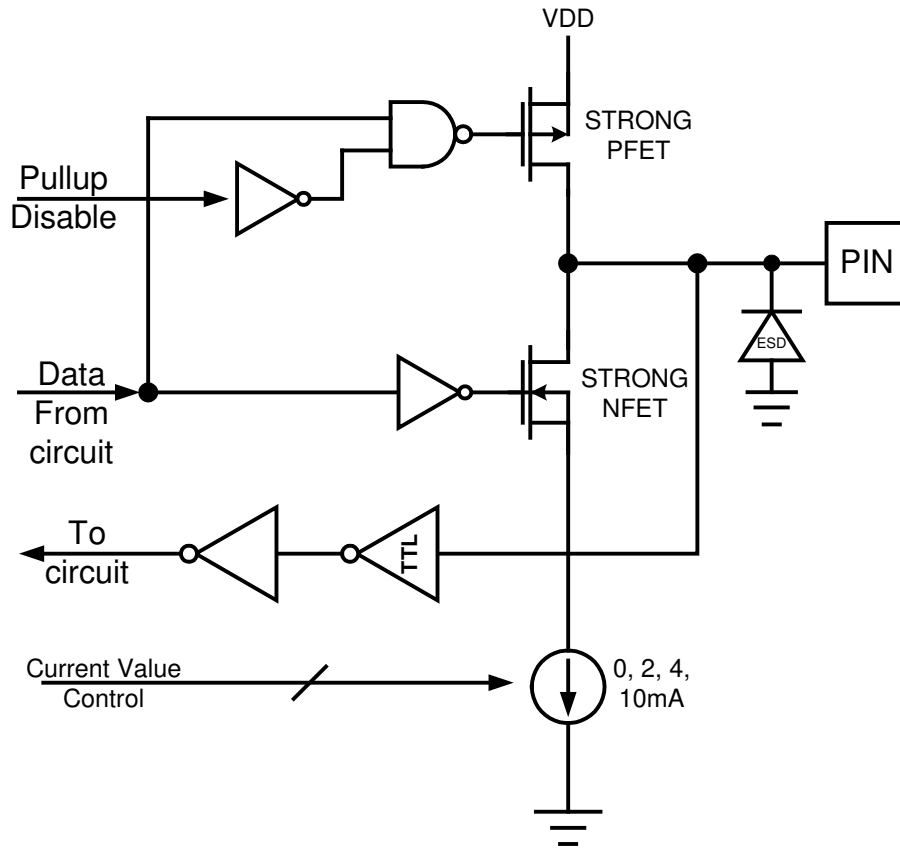


Figure 36: LED Circuit

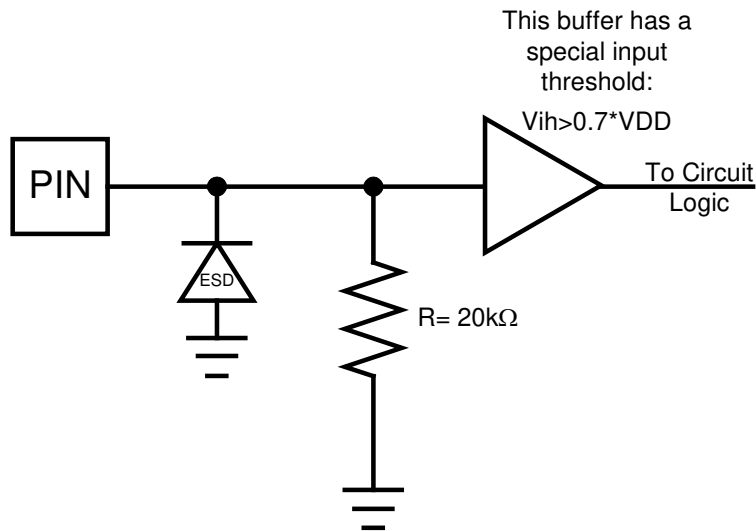


Figure 37: Test and Security Pin Circuit

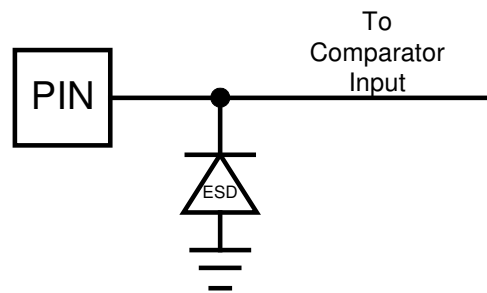


Figure 38: Analog Input Circuit

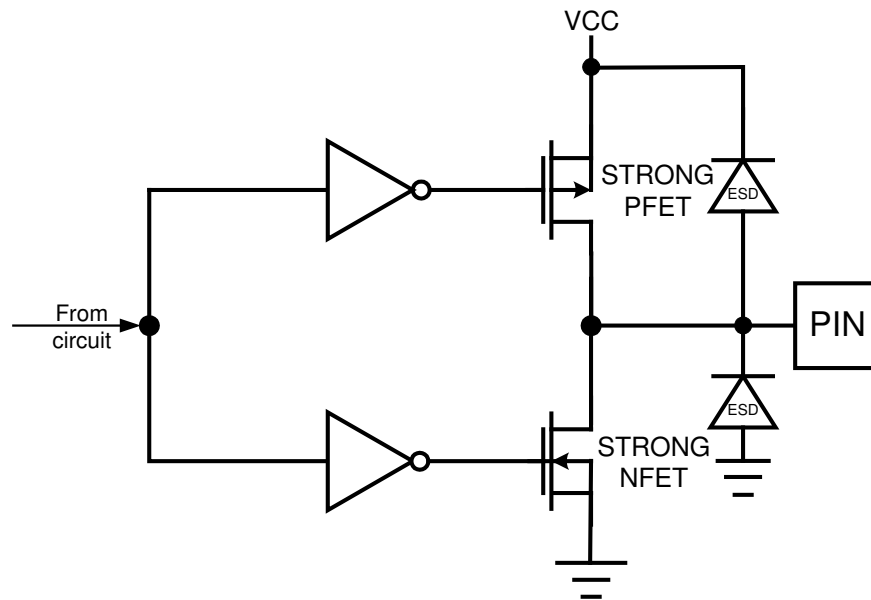


Figure 39: Smart Card Output Circuit

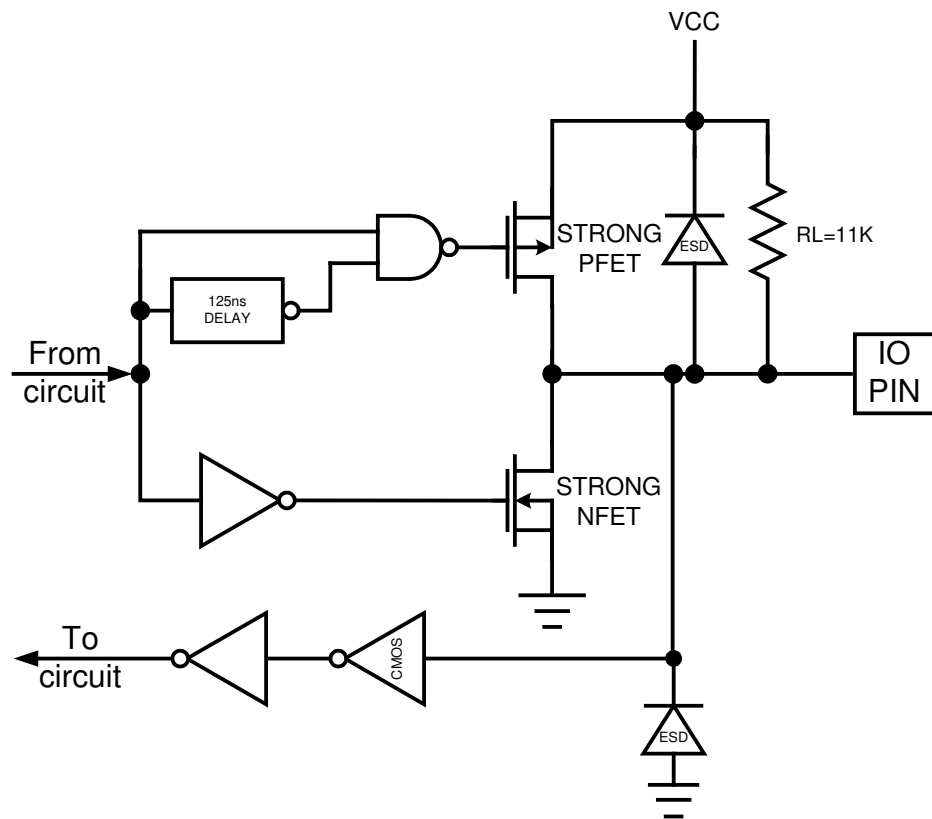


Figure 40: Smart Card I/O Circuit

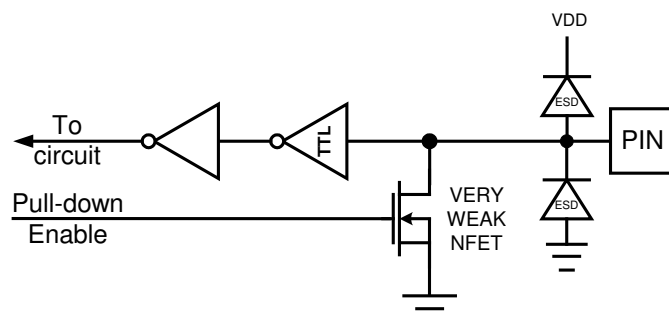


Figure 41: PRES Input Circuit

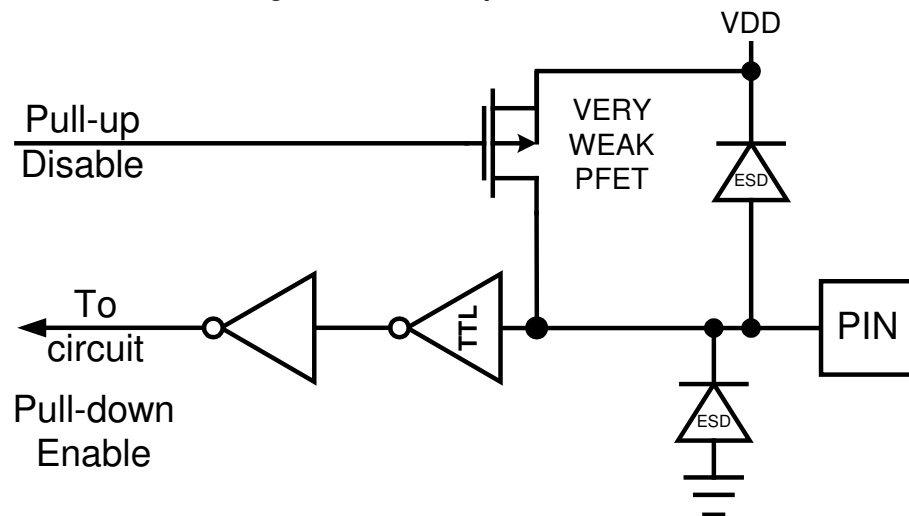


Figure 42: PRESB Input Circuit

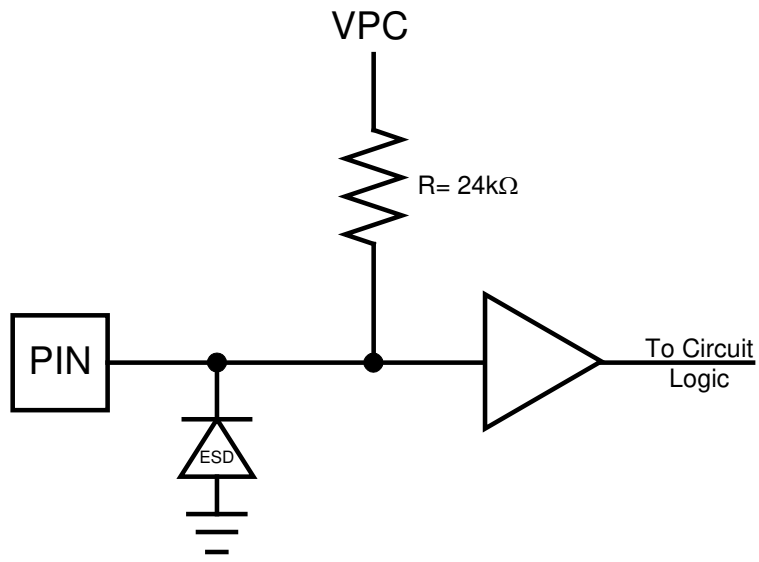


Figure 43: ON\_OFF Input Circuit

## 5 Package Pin Designation

### 5.1 68-pin QFN Pinout

CAUTION: Use handling procedures necessary for a static sensitive component

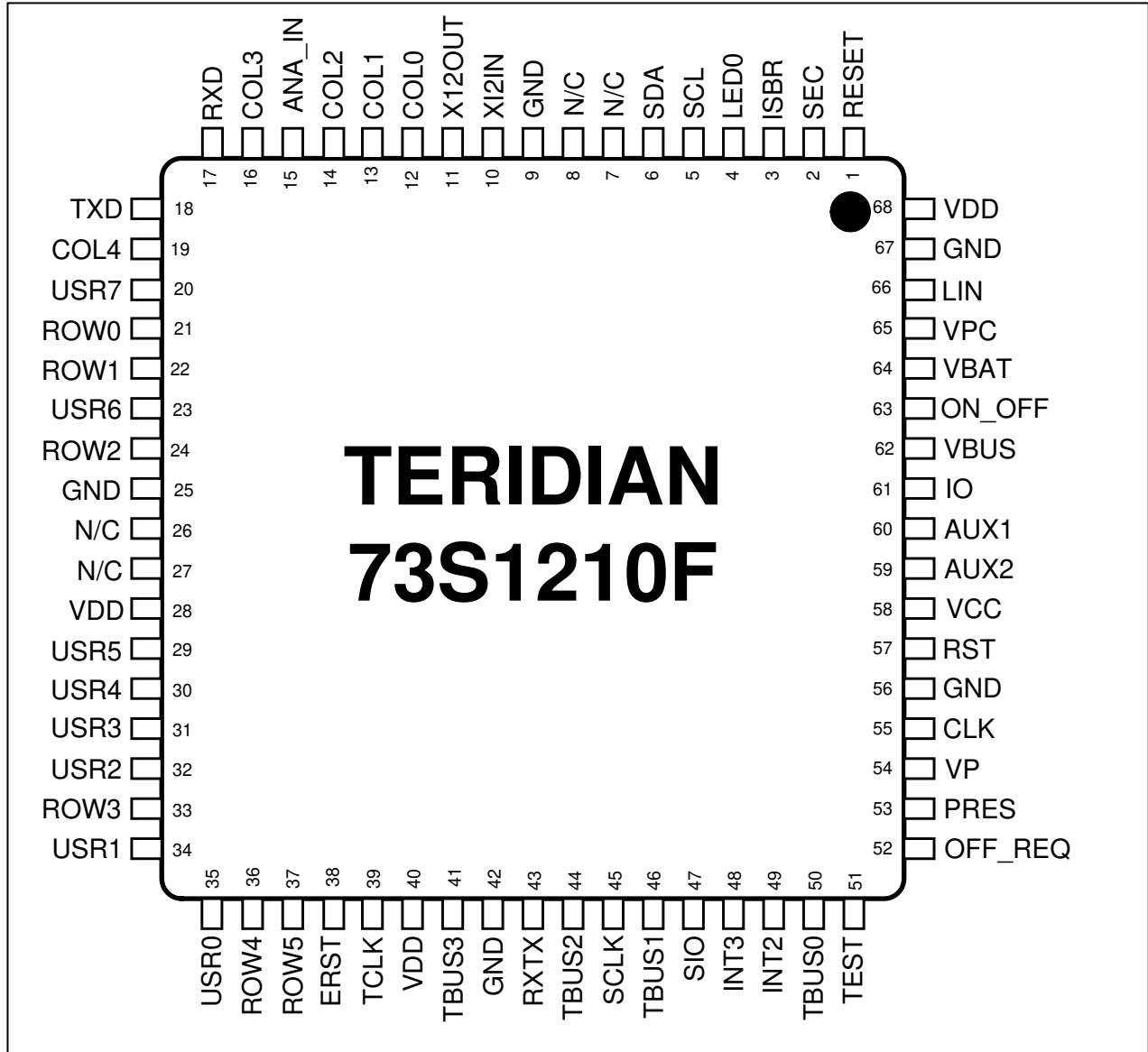


Figure 44: 73S1210F 68 QFN Pinout



## 5.2 44-pin QFN Pinout

CAUTION: Use handling procedures necessary for a static sensitive component.

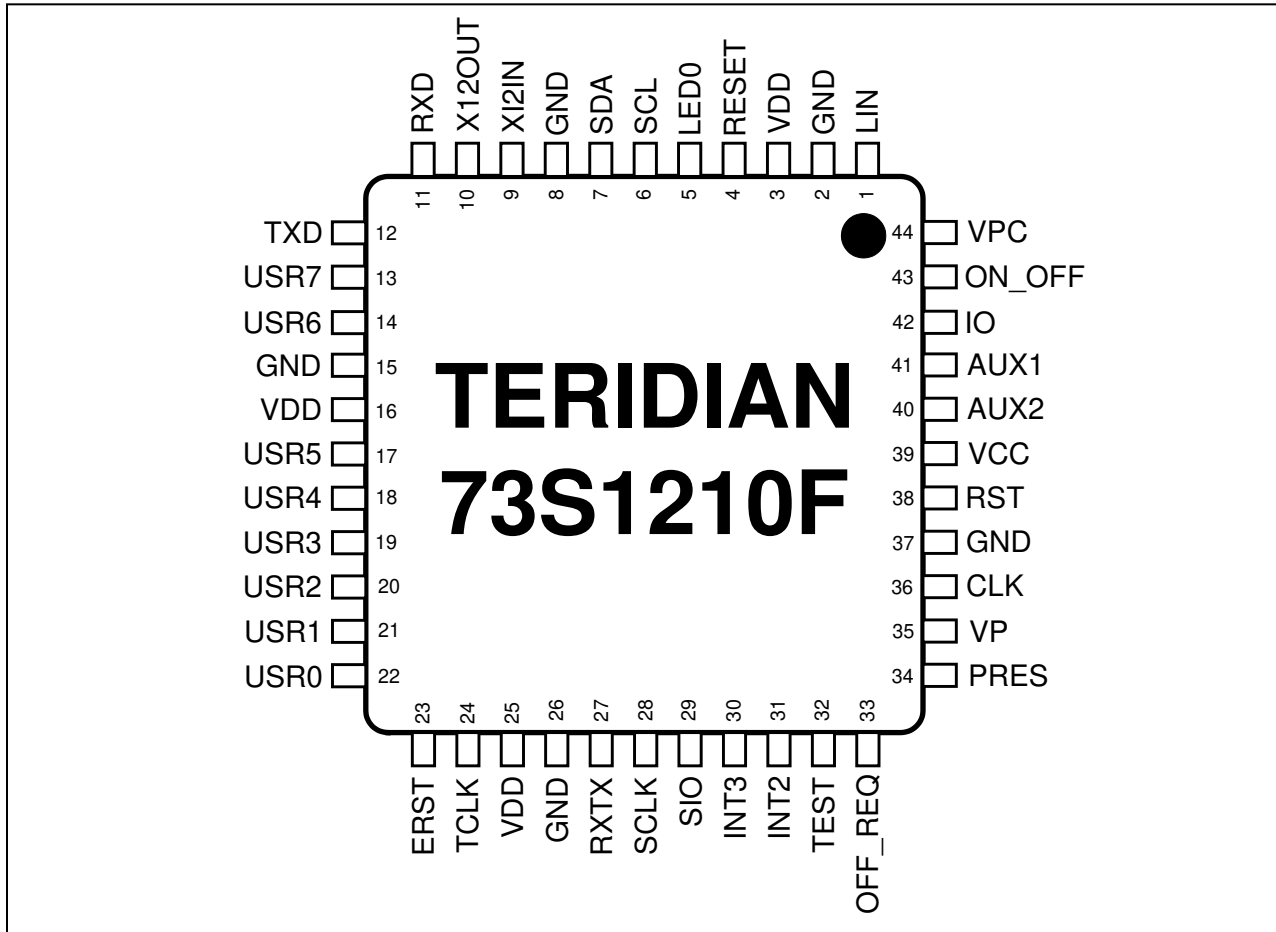


Figure 45: 73S1210F 44 QFN Pinout

## 6 Packaging Information

### 6.1 68-Pin QFN Package Outline

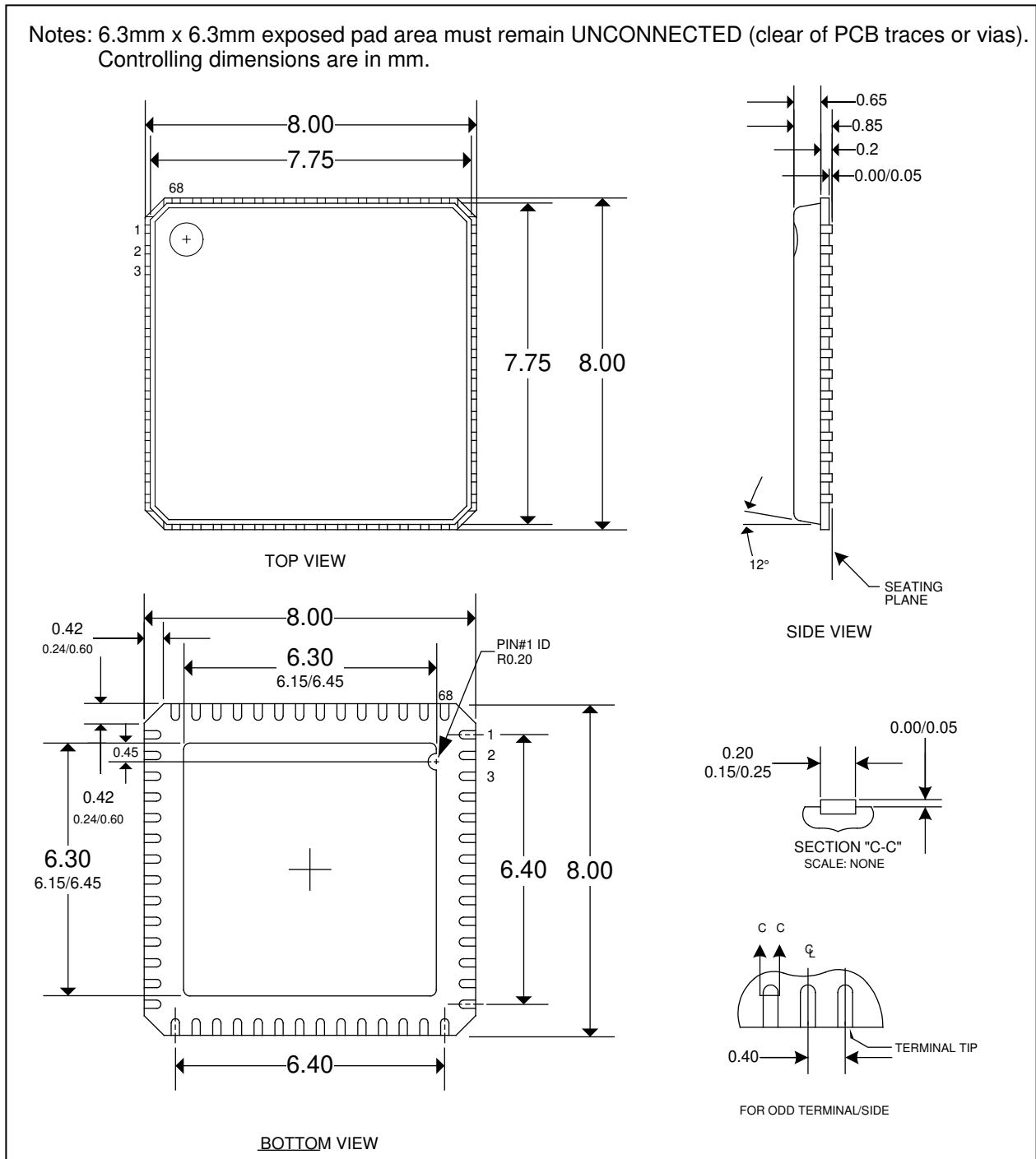


Figure 46: 73S1210F 68 QFN Mechanical Drawing

### 6.2 44-Pin QFN Package Outline

Notes: 5.1mm x 5.1mm exposed pad area must remain UNCONNECTED (clear of PCB traces or vias). Controlling dimensions are in mm.

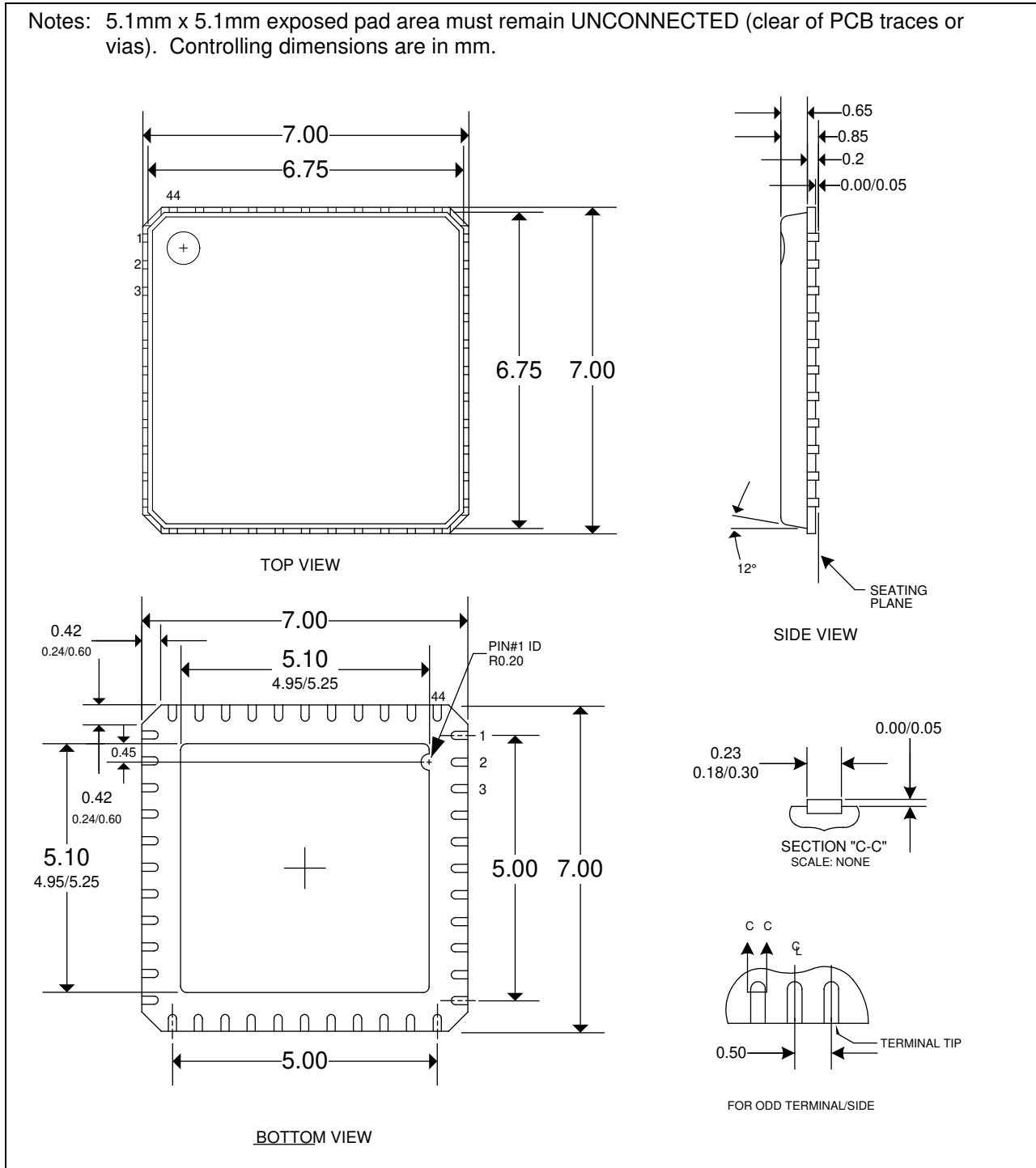


Figure 47: 73S1210F 44 QFN Package Drawing

## 7 Ordering Information

Table 109 lists the order numbers and packaging marks used to identify 73S1210F products.

**Table 109: Order Numbers and Packaging Marks**

Part Description	Order Number	Packaging Mark
73S1210F 68-Pin QFN, Lead Free	73S1210F-68IM/F	73S1210F68IM
73S1210F 68-Pin QFN, Lead Free with Programming	73S1210F-68IM/F/P	73S1210F68IM
73S1210F 68-Pin QFN, Lead Free, Tape and Reel	73S1210F-68IMR/F	73S1210F68IM
73S1210F 68-Pin QFN, Lead Free, Tape and Reel with Programming	73S1210F-68IMR/F/P	73S1210F68IM
73S1210F 44-Pin QFN, Lead Free	73S1210F-44IM/F	73S1210F44IM
73S1210F 44-Pin QFN, Lead Free with Programming	73S1210F-44IM/F/P	73S1210F44IM
73S1210F 44-Pin QFN, Lead Free, Tape and Reel	73S1210F-44IMR/F	73S1210F44IM
73S1210F 44-Pin QFN, Lead Free, Tape and Reel with Programming	73S1210F-44IMR/F/P	73S1210F44IM

## 8 Related Documentation

The following 73S1210F documents are available from Teridian Semiconductor Corporation:

*73S1210F Data Sheet* (this document)  
*73S1210F Development Board Quick Start Guide*  
*73S1210F Software Development Kit Quick Start Guide*  
*73S1210F Evaluation Board User's Guide*  
*73S12xxF Software User's Guide*  
*73S12xxF Synchronous Card Design Application Note*

## 9 Contact Information

For more information about Teridian Semiconductor products or to check the availability of the 73S1210F, contact us at:

6440 Oak Canyon Road  
 Suite 100  
 Irvine, CA 92618-5201

Telephone: (714) 508-8800  
 FAX: (714) 508-8878  
 Email: [scr.support@teridian.com](mailto:scr.support@teridian.com)

For a complete list of worldwide sales offices, go to <http://www.teridian.com>.

## Revision History

Revision	Date	Description
1.0	5/10/2007	First publication.
1.1	11/6/2007	<p>In <a href="#">Table 1</a>, added Equivalent Circuit references.</p> <p>In <a href="#">Section 1.4</a>, updated program security description to remove pre-boot and 32-cycle references.</p> <p>In <a href="#">Section 1.7.1</a>, changed “Mcount is configured in the MCLKCtl register must be bound between a value of 1 to 7. The possible crystal or external clock are shown in Table 12.” to “Mcount is configured in the MCLKCtl register must be bound between a value of 1 to 7. The possible crystal or external clock frequencies for getting MCLK = 96MHz are shown in Table 11.”</p> <p>In the <a href="#">BRCON</a> description, changed “If BSEL = 1, the baud rate is derived using timer 1.” to “If BSEL = 0, the baud rate is derived using timer 1.”</p> <p>In <a href="#">Section 1.7.14</a>, removed the following from the emulator port description: “The signals of the emulator port have weak pull-ups. Adding resistor footprints for signals E_RST, E_TCLK and E_RXTX on the PCB is recommended. If necessary, adding 10KΩ pull-up resistors on E_TCLK and E_RXTX and a 3KΩ on E_RST will help the emulator operate normally if a problem arises.”</p> <p>In <a href="#">Ordering Information</a>, removed the leaded part numbers.</p>
1.2	12/15/2008	<p>In <a href="#">Table 1</a>, added the “Pin (44 QFN)” column.</p> <p>In <a href="#">Table 1</a>, added more description to the SCL, SDA, PRES, VCC, VPC, SEC, TEST and VDD pins.</p> <p>In <a href="#">Section 1.3.2</a>, changed “FLSH_ERASE” to “ERASE” and “FLSH_PGADR” to “PGADDR”. Added “The PGADDR register denotes the page address for page erase. The page size is 512 (200h) bytes and there are 128 pages within the flash memory. The PGADDR denotes the upper seven bits of the flash memory address such that bit 7:1 of the PGADDR corresponds to bit 15:9 of the flash memory address. Bit 0 of the PGADDR is not used and is ignored.” In the description of the <a href="#">PGADDR register</a>, added “Note: the page address is shifted left by one bit (see detailed description above).”</p> <p>In <a href="#">Table 5</a>, changed “FLSHCRL” to “FLSHCTL”.</p> <p>In <a href="#">Table 5</a>, removed the PREBOOT bit description.</p> <p>In <a href="#">Table 5</a>, moved the TRIMPctl bit description to FUSEctl and moved the FUSEctl bit description to TRIMPctl.</p> <p>In <a href="#">Table 6</a>, changed “PGADR” to “PGADDR”.</p> <p>In <a href="#">Table 7</a>, added PGADDR.</p> <p>In <a href="#">Table 8</a>, changed the reset value for RTCCtl from “0x81” to “0x00”. Added the RTCTrim0 and ACOMP registers. Deleted the OMP, VRctl, LEDCal and LOCKctl registers.</p> <p>In <a href="#">Table 7</a>, removed the Mcount 7 row.</p> <p>In <a href="#">Table 50</a> through <a href="#">Table 53</a>, changed the names of registers USRIntCtl0 through USRIntCtl3 to USRIntCtl1 through USRIntCtl4.</p> <p>In <a href="#">TCON</a>, corrected the descriptions for TCON.2 and TCON.0.</p> <p>In <a href="#">Section 1.7.9</a>, added a note about USR pins defaulting as inputs after reset.</p> <p>Changed the register address for <a href="#">ATRMsb</a> from FE21 to FE1F.</p>

		<p>In <a href="#">Section 1.7.15.5</a>, deleted “The ETU clock is held in reset condition until the activation sequence begins (either by VCCOK=1 or VCCTMR timeout) and will go high ½ the ETU period thereafter.”</p> <p>In <a href="#">Section 1.7.15.5</a>, added “Synchronous card operation is broken down into three primary types. These are commonly referred to as 2-wire, 3-wire and I2C synchronous cards. Each card type requires different control and timing and therefore requires different algorithms to access. Teridian has created an application note to provide detailed algorithms for each card type. Refer to the application note titled <i>73S12xxF Synchronous Card Design Application Note</i>.”</p> <p>In <a href="#">Table 78</a> and <a href="#">Table 107</a>, changed the SYCKST bit to I2CMODE.</p> <p>In <a href="#">Figure 25</a>, replaced the schematic with a new schematic.</p> <p>In <a href="#">Section 3.4</a>, changed the Fxtal Min from 4 to 6.</p> <p>Added <a href="#">44-pin QFN package</a>.</p> <p>Added <a href="#">Section 8, Related Documentation</a>.</p> <p>Added <a href="#">Section 9, Contact Information</a>.</p> <p>Formatted the document per new standard. Added section numbering.</p>
1.3	1/22/2009	Changed the value for the <a href="#">I<sub>DD_IN</sub> Power Down (25°C)</a> parameter from 13 µA to 15 µA.
1.4	5/12/2009	In <a href="#">Table 1</a> , corrected the 44 QFN GND pin from 37 to 26. Added the “with Programming” ordering numbers to <a href="#">Table 109</a> .

© 2009 Teridian Semiconductor Corporation. All rights reserved.  
Teridian Semiconductor Corporation is a registered trademark of Teridian Semiconductor Corporation.  
Windows is a registered trademark of Microsoft Corporation.  
Signum Systems is a trademark of Signum Systems Corporation.  
All other trademarks are the property of their respective owners.

Teridian Semiconductor Corporation makes no warranty for the use of its products, other than expressly contained in the Company’s warranty detailed in the Teridian Semiconductor Corporation standard Terms and Conditions. The company assumes no responsibility for any errors which may appear in this document, reserves the right to change devices or specifications detailed herein at any time without notice and does not make any commitment to update the information contained herein. Accordingly, the reader is cautioned to verify that this document is current by comparing it to the latest version on <http://www.teridian.com> or by checking with your sales representative.

Teridian Semiconductor Corp., 6440 Oak Canyon, Suite 100, Irvine, CA 92618  
TEL (714) 508-8800, FAX (714) 508-8877, <http://www.teridian.com>