

NOTES:

- MATERIALS AND FINISHES:**
 - INSULATOR: GLASS FILLED PLASTIC UL 94 V-0 RATED, GREY RAL 7035
 - CONTACTS: COPPER ALLOY, PLATING MATING AREA: 0,8 µM GOLD OVER NICKEL
PLATING TERMINATION AREA: 0,8-1,5 µM TIN (SN 100)
- ELECTRICAL CHARACTERISTICS:**

CREEPING AND CLEARANCE DISTANCE; MINIMUM SPACING:

 - CONTACTS 5-16 TO ANY OTHER CONTACT WITHIN THIS GROUP: 0,7 MM
 - CONTACTS 17-24 TO ANY OTHER CONTACT WITHIN THIS GROUP: 2,5 MM
 - CONTACT 25 TO 26: 5,5 MM
 - CONTACTS 27-34 TO ANY OTHER CONTACT WITHIN THIS GROUP: 1,4 MM
 - CONTACTS 13-16 TO 17-20: 3,0 MM
 - CONTACTS 21-24 TO 25-26: 4,0 MM
 - CONTACTS 25-26 TO 27-29: 2,0 MM

CONTACT CURRENT RATING:

 - POWER CONTACTS: 16 AMPERES MINIMUM,
TESTED PER CSA C22.2 NO. 182.3-M1987, ALL CONTACTS UNDER LOAD
 - SIGNAL CONTACTS: 2 AMPERES NOMINAL

INITIAL CONTACT RESISTANCE PER IEC 512-2, TEST 2b:

 - POWER CONTACTS: 0,0022 OHM MAX.
 - SIGNAL CONTACTS: 0,0085 OHM MAX.

INSULATION RESISTANCE: 5 G OHM PER IEC 512-2, TEST 3a, METHOD A
- POSITIONS WITHOUT CONTACTS:** 1, 2, 3, 4
- WORKING TEMPERATURE:** -55°C TO +125°C
- PRESS-FIT PART OF CONTACTS ARE PATENT PROTECTED**
- CONNECTOR IS PART MARKED:** [PART-NO. CONEC ABC]

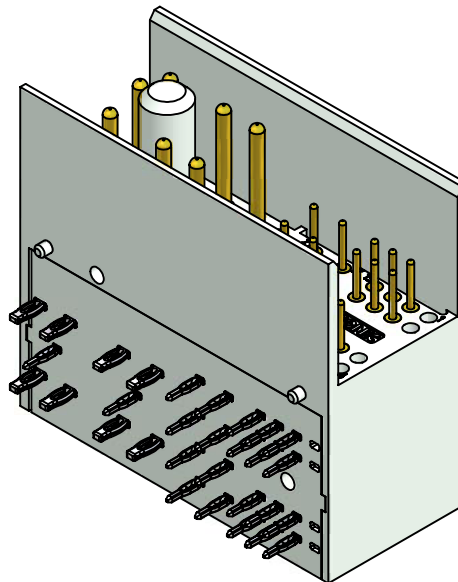

Drilled hole
Ø1,15±0,025 (22x)

Copper thickness
minimum 25µm

Tin thickness
minimum 15µm

Finished hole
Ø1^{+0,09}_{-0,06} (22x)

A (10:1)

Drilled hole
Ø1,75±0,025 (8x)

Copper thickness
minimum 25µm

Tin thickness
minimum 15µm

Finished hole
Ø1,6^{+0,09}_{-0,06} (8x)

B (10:1)

PCB hole pattern

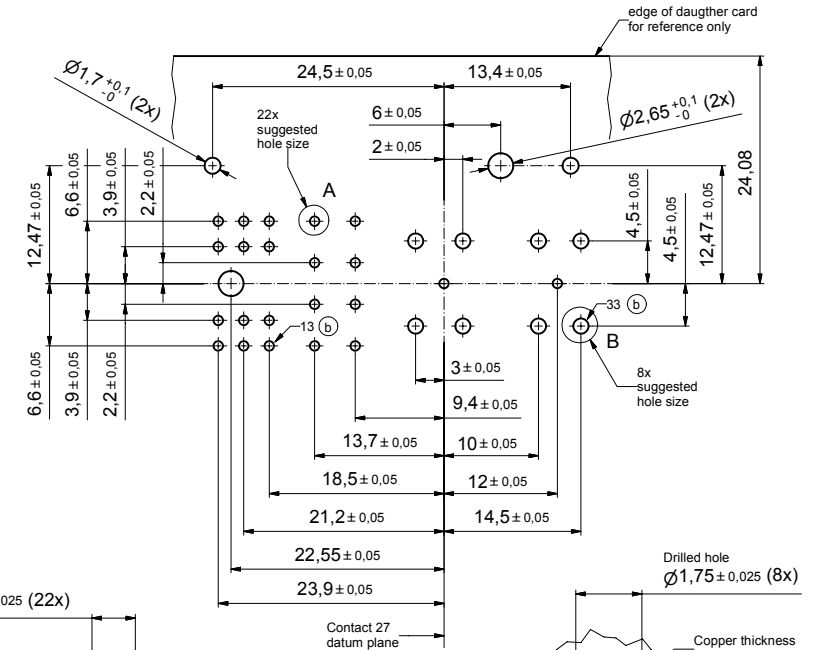

1	Fixing plate	13		
5	Signal contact type 7	12		
3	Signal contact type 6	11		
2	Signal contact type 5	10		
2	Signal contact type 4	9		
2	Signal contact type 3	8		
3	Signal contact type 2	7		
5	Signal contact type 1	6		
3	Power contact type 4	5		
1	Power contact type 3	4		
3	Power contact type 2	3		
1	Power contact type 1	2		
1	Case 34pos. male	1		
quantity	part description	partlist	item	dwg no. / norm material

finish: see notes		tolerance ISO 2768-m	scale: 2,5:1 (10:1)
date		name	material: see notes
drawn	22.08.05	Mankopf	
appd.	22.08.05	Kühle	
norm			
title: MALE CONNECTOR 30pos. PRESS-FIT ANGLED AdvancedTCA			dwg no: [Inventor]
5 x c	A 3057	21.07.08	Lehm. d-old
2 x b	A 2592	23.10.06	HS
a	Origin		
CONEC		dwg no: 46K2A005	DIN-A2
part no: ATC30W08MAE1S5X		sh: 1	

