

| LOC | DIST | REVISIONS |     |               |         |     |      |
|-----|------|-----------|-----|---------------|---------|-----|------|
| DW  | -    | P         | LTR | DESCRIPTION   | DATE    | DWN | APVD |
|     |      | C         |     | ECR-15-001514 | 10OCT15 | I.T | W.H  |

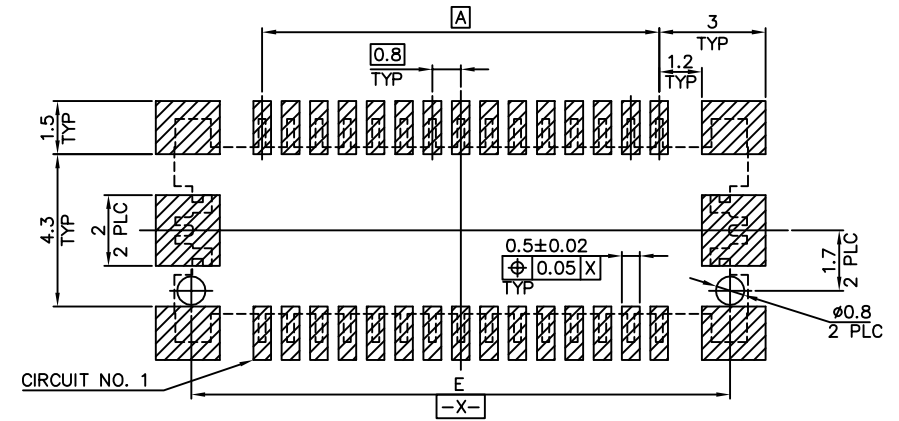

TOLERANCE: ±0.05  
 RECOMMENDED PCB LAYOUT  
 (TOP VIEW)

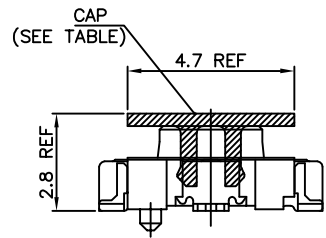
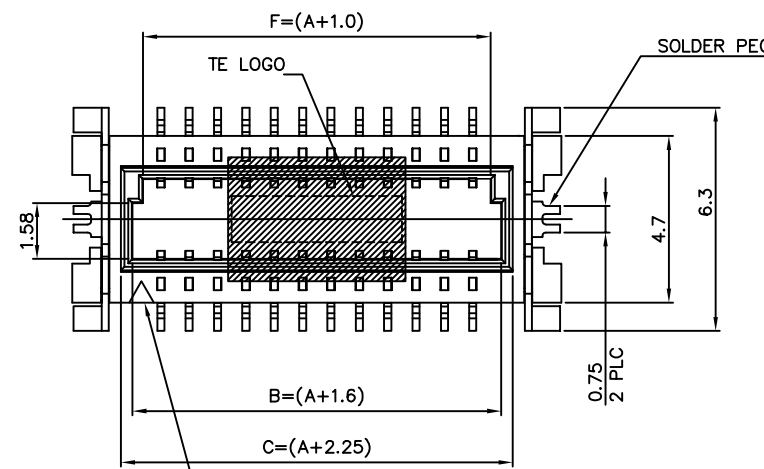
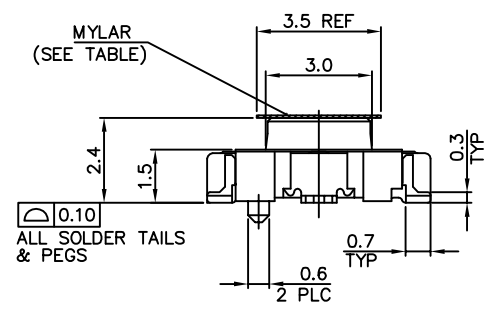
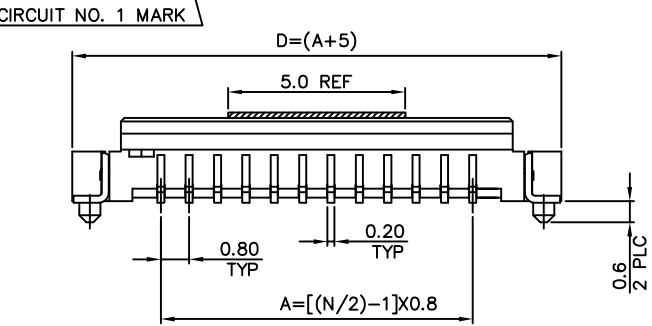

- NOTES:
- MATERIAL:  
 HOUSING: PA6T, WITH 30% GF, UL 94V-0, NATURAL COLOR.  
 CONTACTS: PHOSPHOR BRONZE.  
 PEGS: BRASS.  
 CAP: PA6T, WITH 30% GF, UL 94V-0, NATURAL COLOR.  
 MYLAR: POLYSTYRENES, ORANGE COLOR.
  - FINISH:  
 CONTACTS:  
 PLATING A: GOLD FLASH.  
 PLATING B: 2.54mm [100m] MIN. MATTE-TIN.  
 (WITH ENTIRE CONTACT UNDERPLATED 1.27mm [50m] MIN. NICKEL)  
 PEGS: 2.54mm [100m] MIN. MATTE-TIN OVER 1.27mm [50m] MIN. NICKEL.  
 RECOMMENDED PART NUMBER OF MATING RECEPTACLE: X-2041201-X
  - REFLOW SOLDER CAPABLE TO 260°C AS PER TEC-109-201, CONDITION B.
  - LOW HALOGEN SPEC:  
 CHLORINE(Cl): 900ppm MAX.  
 BROMIN(Br): 900ppm MAX.

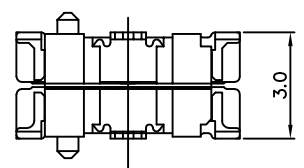

△ STACKING HEIGHT

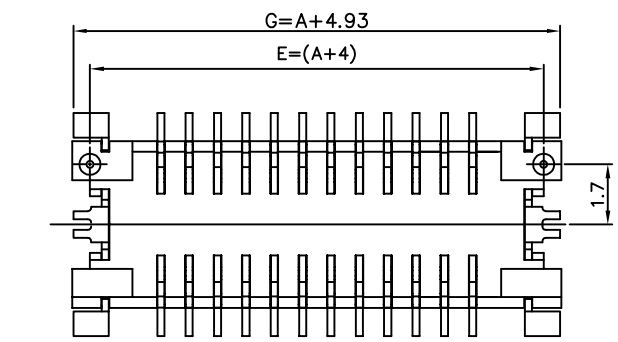

| SHEET    | MATERIAL         | QTY             | WEIGHT (GRAMS) | G          | F   | E    | D    | C     | B    | A   | NO. OF CONTACTS | PART NUMBER            |
|----------|------------------|-----------------|----------------|------------|-----|------|------|-------|------|-----|-----------------|------------------------|
| SHEET 2. | MYLAR            | B               | 0.199          | 13.73      | 9.8 | 12.8 | 13.8 | 11.05 | 10.4 | 8.8 | 24              | <del>2-2041173-4</del> |
| SHEET 3. | MYLAR            | B               | 0.125          | 8.93       | 5   | 8    | 9    | 6.25  | 5.6  | 4.0 | 12              | 1-2041173-2            |
| SHEET 2. | MYLAR            | A               | 0.125          | 8.93       | 5   | 8    | 9    | 6.25  | 5.6  | 4.0 | 12              | <del>2041173-4</del>   |
| SHEET 3. | CAP              | B               | 0.125          | 8.93       | 5   | 8    | 9    | 6.25  | 5.6  | 4.0 | 12              | <del>2041173-3</del>   |
| SHEET 2. | MYLAR            | A               | 0.199          | 13.73      | 9.8 | 12.8 | 13.8 | 11.05 | 10.4 | 8.8 | 24              | <del>2041173-2</del>   |
| PACKAGE  | PICK UP MATERIAL | CONTACT PLATING | WEIGHT (GRAMS) | DIMENSIONS |     |      |      |       |      |     | NO. OF CONTACTS | PART NUMBER            |

THIS DRAWING IS A CONTROLLED DOCUMENT.

DWN: A. WU, 16NOV2009  
 CHK: S. CHIEN, 16NOV2009  
 APVD: W. KODAMA, 16NOV2009

NAME: BOARD-TO-BOARD CONNECTOR, 0.8 MM PITCH, FINE-STACK, 3H, PLUG

PRODUCT SPEC: 108-57488

APPLICATION SPEC: -

WEIGHT: SEE TABLE

CUSTOMER DRAWING

SCALE: - SHEET: 1 of 3 REV: C

SIZE: A3 CAGE CODE: 00779 DRAWING NO: G=2041173 RESTRICTED TO: -

THIS DRAWING IS UNPUBLISHED. RELEASED FOR PUBLICATION  
 © COPYRIGHT 2009 BY TYCO ELECTRONICS CORPORATION. ALL RIGHTS RESERVED.

| LOC | DIST | REVISIONS    |      |     |      |
|-----|------|--------------|------|-----|------|
| P   | LTR  | DESCRIPTION  | DATE | DWN | APVD |
| DW  | -    | SEE SHEET 1. |      |     |      |

NOTES:

- MATERIAL:  
 BOX: FIBREBOARD, CORRUGATED, DOUBLE WALL.  
 COVER TAPE: POLYSTYRENES, 120°C HEAT-RESISTANT TEMPERATURE, TRANSPARENT COLOR.  
 CARRIER TAPE: POLYSTYRENES, 120°C HEAT-RESISTANT TEMPERATURE, TRANSPARENT COLOR.  
 REEL: HIPS, 70°C HEAT-RESISTANT TEMPERATURE, BLUE COLOR.  
 BAG: POLYETHYLENES, 100°C HEAT-RESISTANT TEMPERATURE, TRANSPARENT COLOR.
- EACH BAG SHALL BE INCLUDED DESICCANT.
- PEELING STRENGTH: 0.1 ~ 1.3 N (10 ~ 130 GRAMS).
- PEELING SPEED: 300 mm/min.

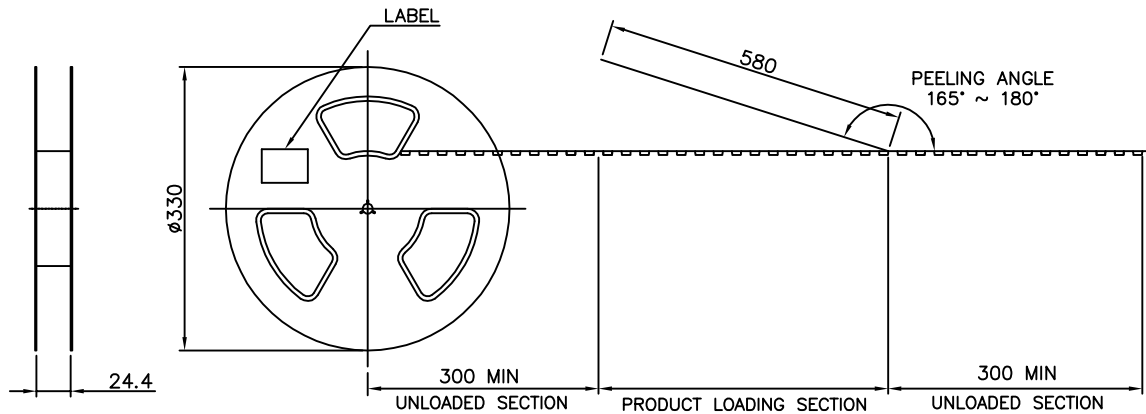

USER DIRECTION OF UNREELING →

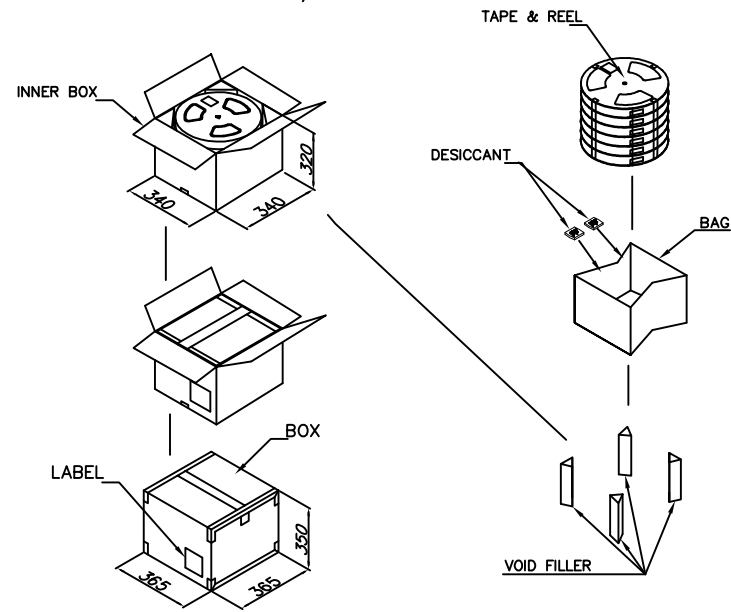
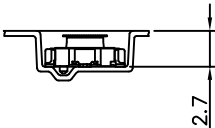
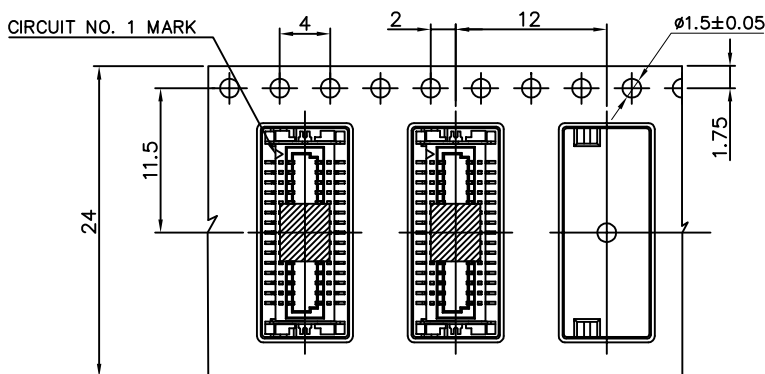

| QUTANTITY | PCS/TAPE | REELS/BOX | G/W (Kg) | N/W (Kg) | NO. OF CONTACTS |
|-----------|----------|-----------|----------|----------|-----------------|
| 15000 PCS | 1500     | 10        | 10.12    | 3.25     | 24              |
|           |          |           | 9.25     | 2.35     | 12              |

THIS DRAWING IS A CONTROLLED DOCUMENT.

|                  |  |           |   |
|------------------|--|-----------|---|
| DWN              | A. WU  | 16NOV2009 |  TE Connectivity |
| CHK              | S. CHIEN   | 16NOV2009 |   |
| APVD             | W. KODAMA  | 16NOV2009 |   |
| NAME             |  |           |   |
| PRODUCT SPEC     | BOARD-TO-BOARD CONNECTOR, 0.8 MM PITCH, FINE-STACK, 3H, PLUG |           |   |
| APPLICATION SPEC | SIZE   |           |   |
| WEIGHT           | A3   | 00779     | C=2041173   |
| CUSTOMER DRAWING | SCALE  | SHEET     | 2 of 3  |
|                  |  | REV       | C   |

THIS DRAWING IS UNPUBLISHED. RELEASED FOR PUBLICATION  
 © COPYRIGHT 2009 BY TYCO ELECTRONICS CORPORATION. ALL RIGHTS RESERVED.

| LOC | DIST | REVISIONS    |      |     |      |
|-----|------|--------------|------|-----|------|
| P   | LTR  | DESCRIPTION  | DATE | DWN | APVD |
| DW  | -    | SEE SHEET 1. |      |     |      |

NOTES:

- MATERIAL:  
 BOX: FIBREBOARD, CORRUGATED, DOUBLE WALL.  
 COVER TAPE: POLYSTYRENES, 120°C HEAT-RESISTANT TEMPERATURE, TRANSPARENT COLOR.  
 CARRIER TAPE: POLYSTYRENES, 120°C HEAT-RESISTANT TEMPERATURE, TRANSPARENT COLOR.  
 REEL: HIPS, 70°C HEAT-RESISTANT TEMPERATURE, BLUE COLOR.  
 BAG: POLYETHYLENES, 100°C HEAT-RESISTANT TEMPERATURE, TRANSPARENT COLOR.
- EACH BAG SHALL BE INCLUDED DESICCANT.
- PEELING STRENGTH: 0.1 ~ 1.3 N (10 ~ 130 GRAMS).
- PEELING SPEED: 300 mm/min.

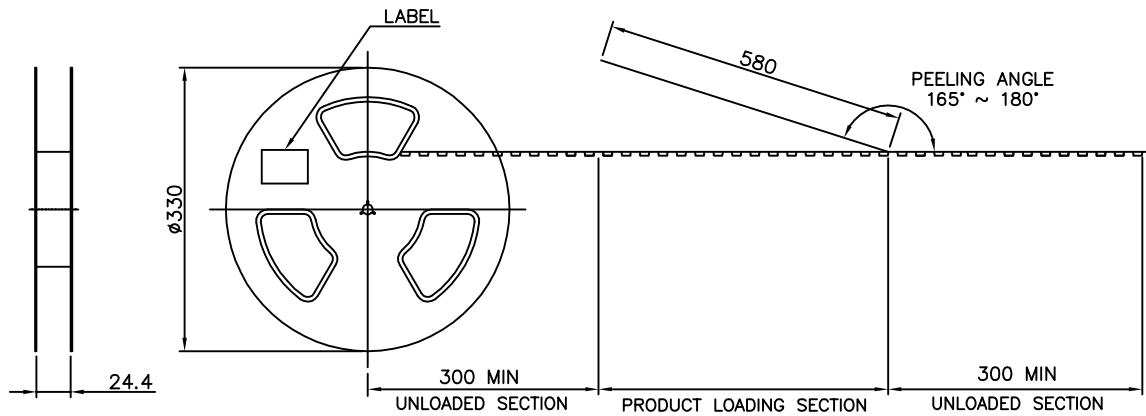

USER DIRECTION OF UNREELING →

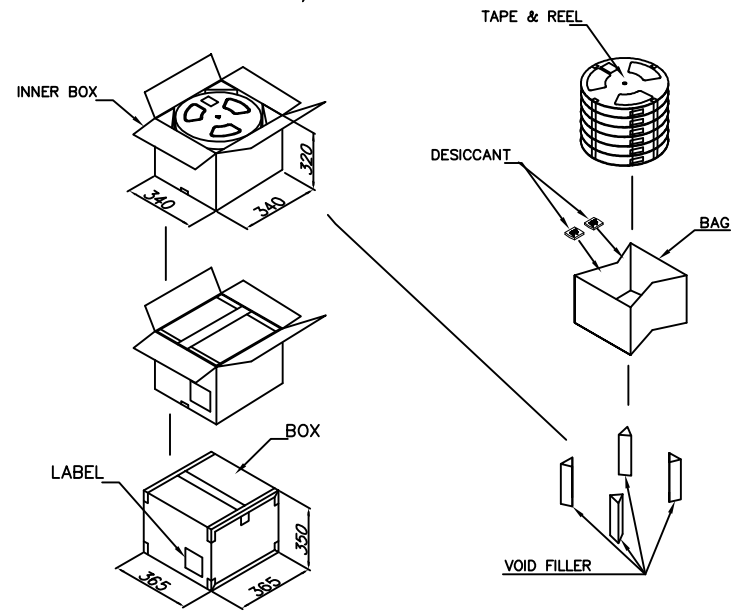
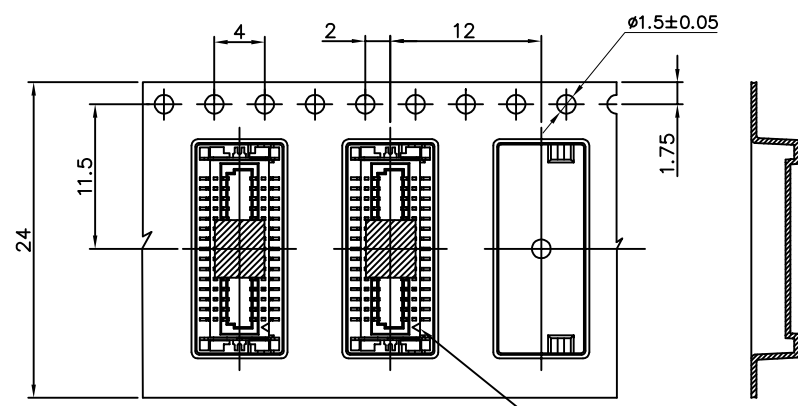

| 15000 PCS | 1500     | 10        | 9.25     | 2.35     | 12              |
|-----------|----------|-----------|----------|----------|-----------------|
| QUANTITY  | PCS/TAPE | REELS/BOX | G/W (Kg) | N/W (Kg) | NO. OF CONTACTS |

THIS DRAWING IS A CONTROLLED DOCUMENT.

|                    |           |           |   |
|--------------------|-----------|-----------|---|
| DWN                | A. WU     | 16NOV2009 | <br>TE Connectivity   |
| CHK                | S. CHIEN  | 16NOV2009 |   |
| APVD               | W. KODAMA | 16NOV2009 |   |
| PRODUCT SPEC       | NAME      |           |   |
| APPLICATION SPEC   | SIZE      |           |   |
| WEIGHT             | CAGE CODE |           |   |
| CUSTOMER DRAWING   |           |           | BOARD-TO-BOARD CONNECTOR,<br>0.8 MM PITCH, FINE-STACK, 3H, PLUG |
| SCALE              |           |           | RESTRICTED TO   |
| A3 00779 C=2041173 |           |           | —   |
| SHEET 3 of 3       |           |           | REV C   |

| DIMENSIONS: | TOLERANCES UNLESS OTHERWISE SPECIFIED: |
|-------------|--|
| MM          |  |
|             | 0 PLC ± -                              |
|             | 1 PLC ± -                              |
|             | 2 PLC ± -                              |
|             | 3 PLC ± -                              |
|             | 4 PLC ± -                              |
|             | ANGLES ± -                             |
| MATERIAL    | FINISH                                 |

