

SDIO Buffers

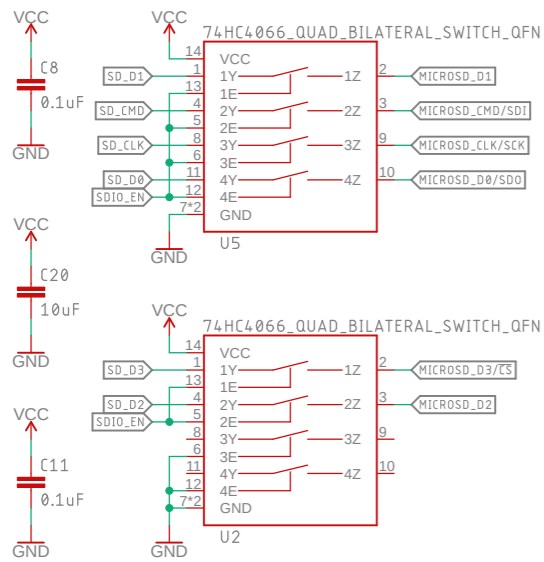

SPI Buffer

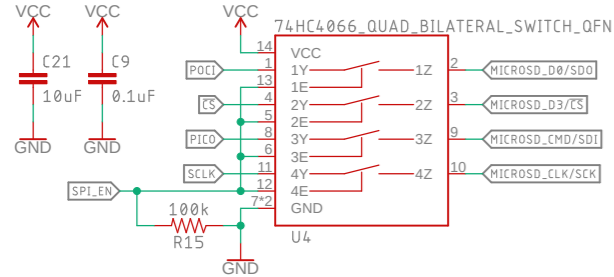

microSD Socket

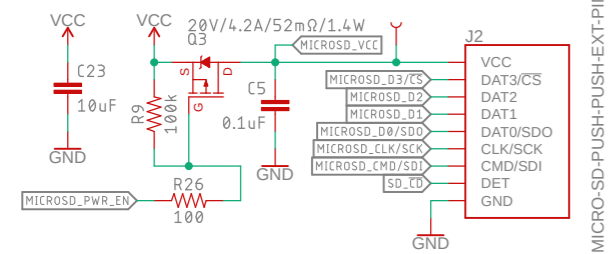

Thing Plus Footprint

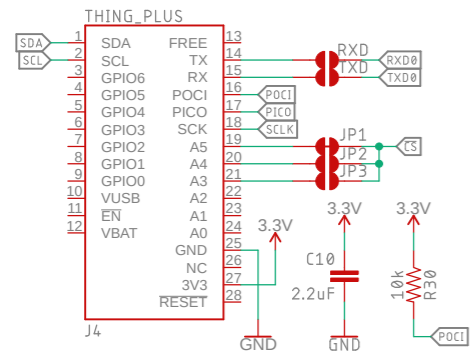

USB to SDIO Interface (USB2241)

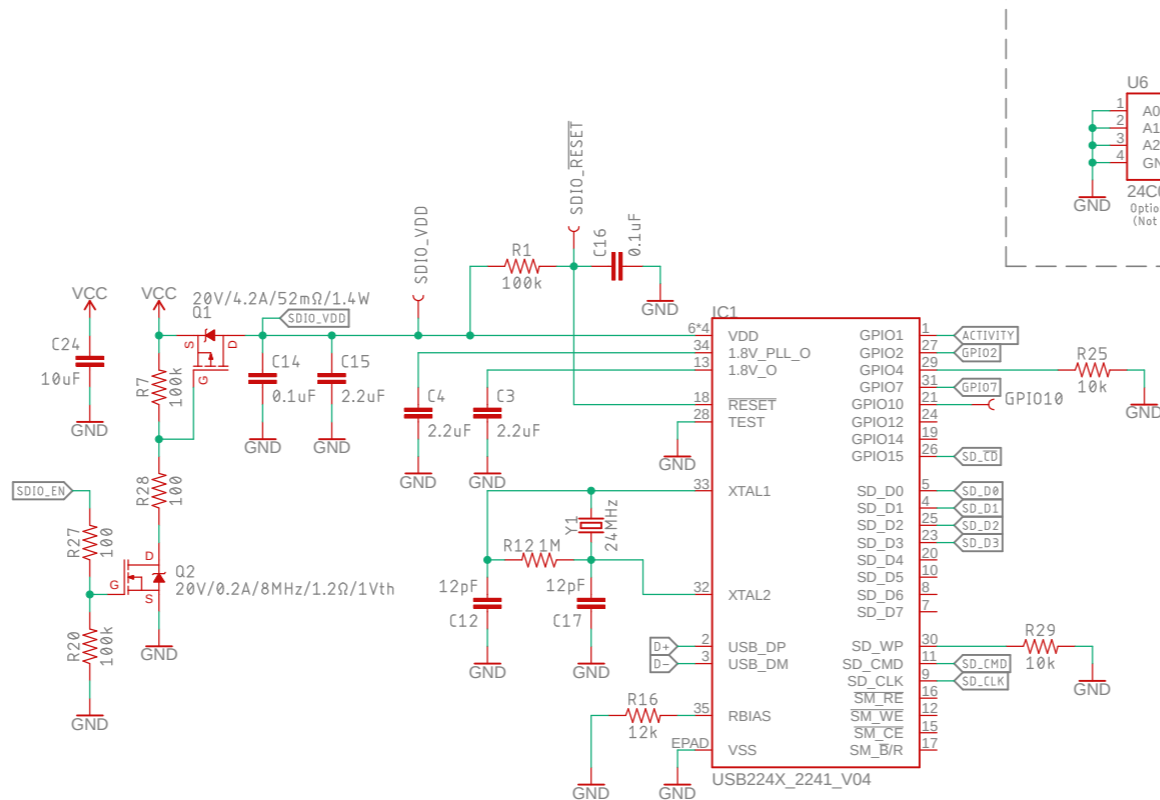

Optional EEPROM

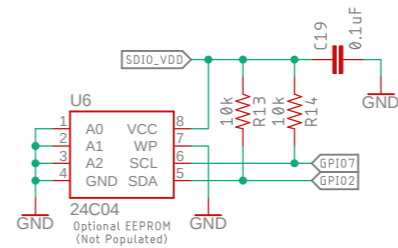

Power Mux

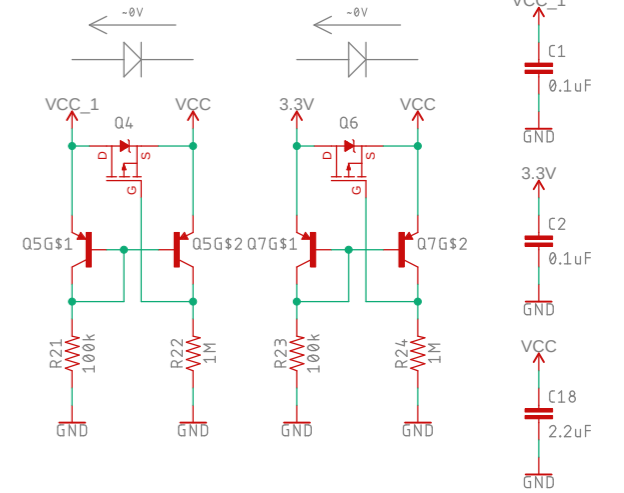

Voltage Sensing

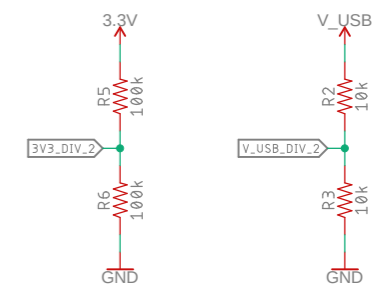

Attiny841

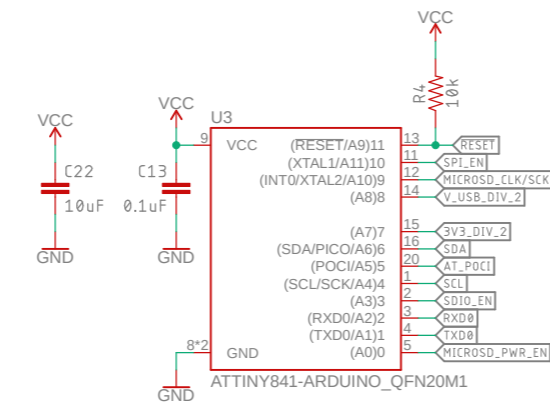

LEDs

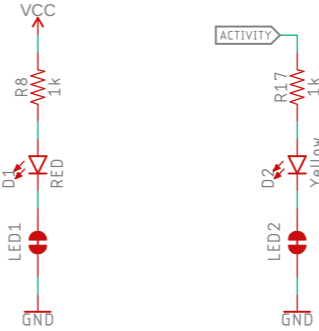

USB

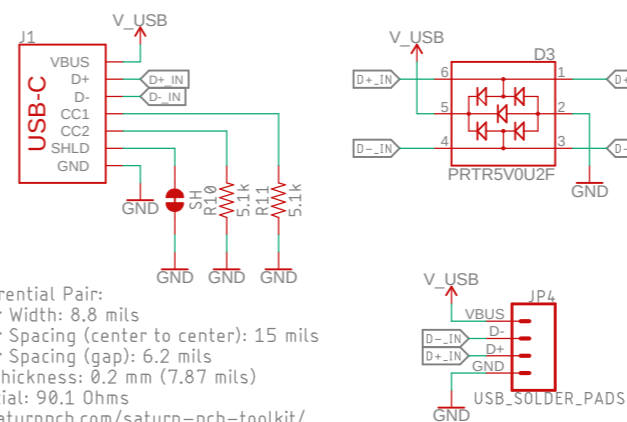

USB Differential Pair:
 Conductor Width: 8.8 mils
 Conductor Spacing (center to center): 15 mils
 Conductor Spacing (gap): 6.2 mils
 Prepreg Thickness: 0.2 mm (7.87 mils)
 Zdifferential: 90.1 Ohms
<https://saturnpcb.com/saturn-pcb-toolkit/>

USB Voltage Regulation

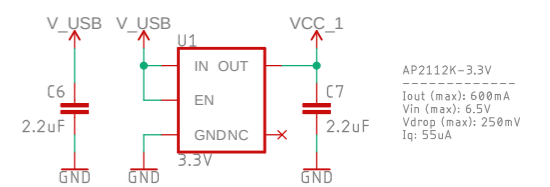

Released under the Creative Commons Attribution Share-Alike 4.0 License
<https://creativecommons.org/licenses/by-sa/4.0/>

TITLE: Dual-Port_Logging_Shield

Design by: Paul Clark

REV: v11

Date: 10/05/2022 10:15

Sheet: 1/1