

1. THIS PLUG WILL MATE WITH ANY 62 POSN., SIZE 4 RECEPTACLE IN AMPLIMITE SERIES.
2. STAINLESS STEEL RETENTION CLIPS ARE INCLUDED IN INSERT ASSEMBLY.
3. THIS CONNECTOR ACCEPTS SIZE 22 PIN CONTACTS.
4. FINISH: CADMIUM PER QQ-P-416; YELLOW CHROMATE.
5. FINISH: ZINC PLATED PER ASTM-B-633 .000200 MIN THK WITH SUPPLEMENTARY CHROMATE (Cr3+).

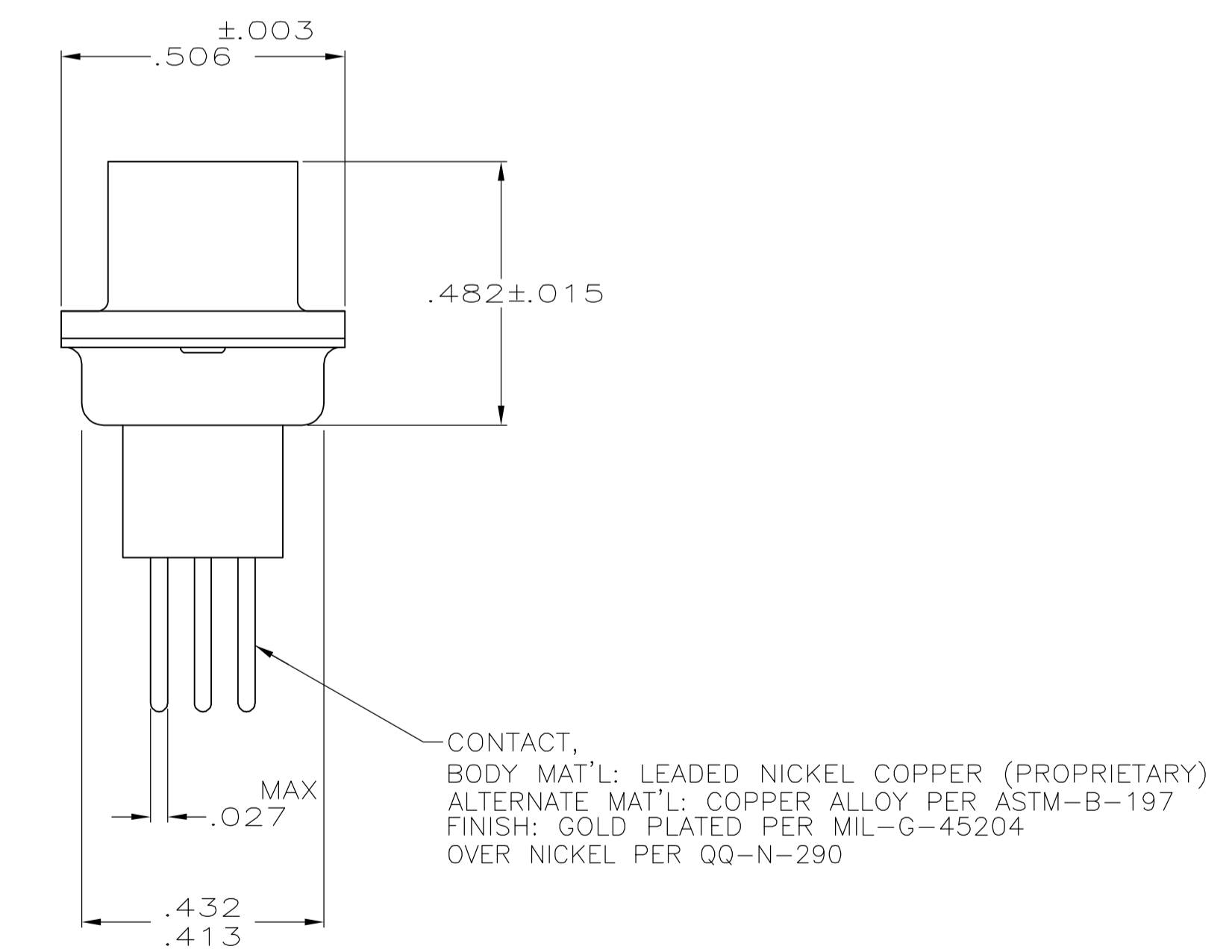
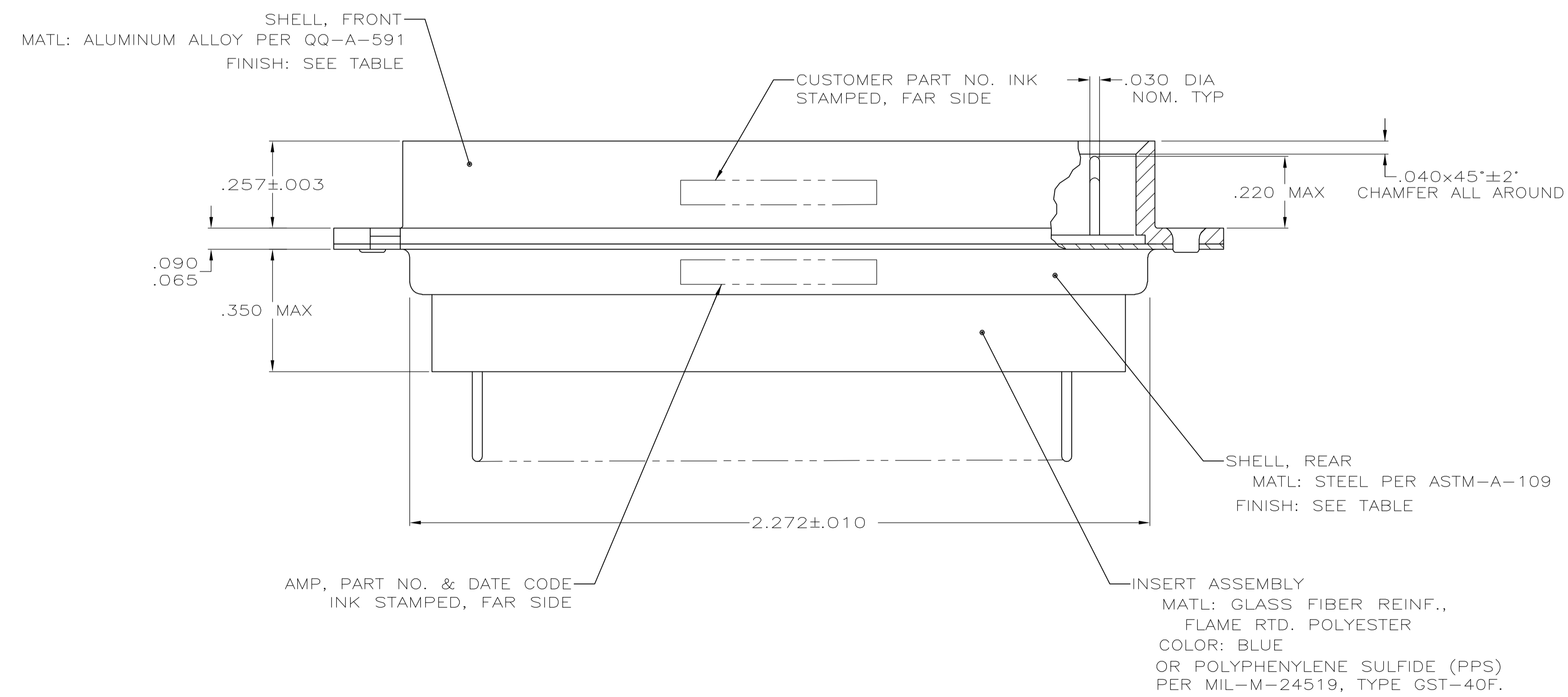
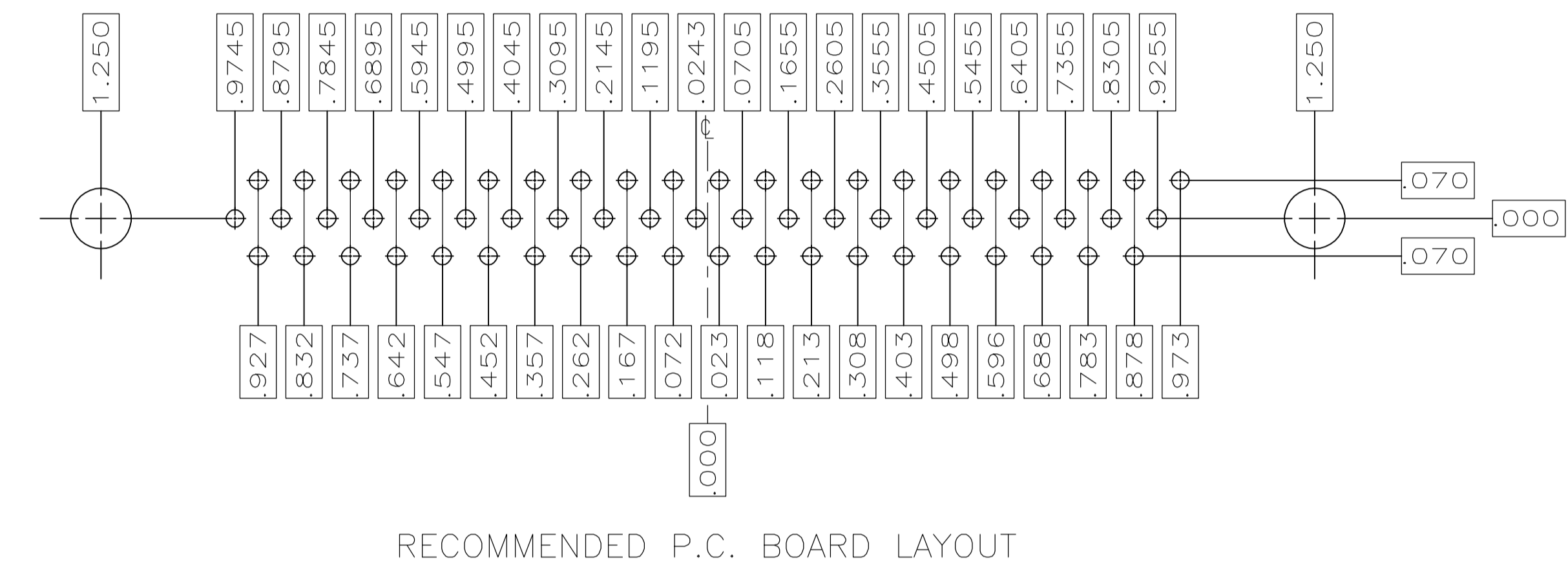
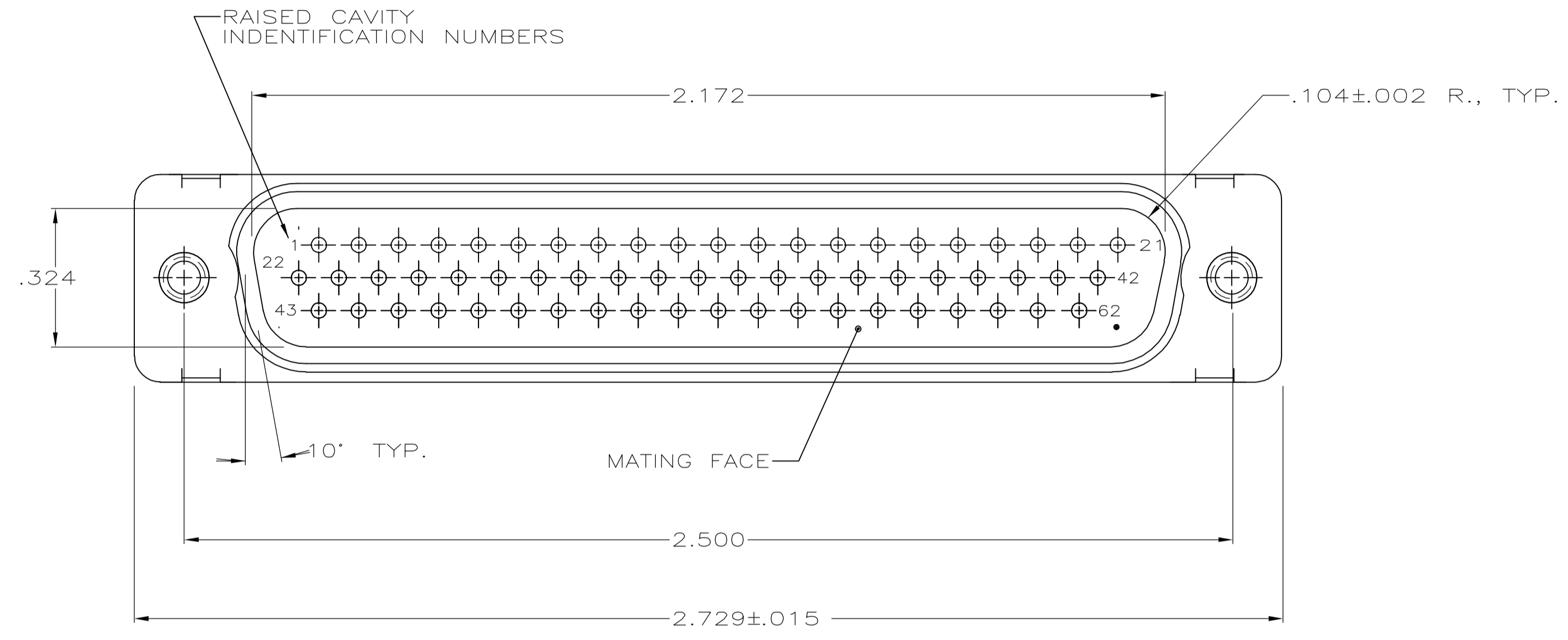

5	5-445089-1
4	445089-1
FINISH	PART NO.

THIS DRAWING IS A CONTROLLED DOCUMENT.		DWN: S. GLATFELTER 12-7-87	Tyco Electronics Corporation Harrisburg, PA 17105-3608
DIMENSIONS: INCHES		CHK: F.C. BALLEW 12-11-87	
TOLERANCES UNLESS OTHERWISE SPECIFIED:		APVD: F. BALLEW 12-11-87	NAME: PLUG ASSEMBLY BLINDMATE AMPLIMITE 62 POSN., SIZE 4, SERIES 90
0 PLC ± -	1 PLC ± -	2 PLC ± -	APPLICATION SPEC
3 PLC ± .005	4 PLC ± -	ANGLES ± 0.30°	SIZE: A1 00779 C=445089
MATERIAL: SEE CALLOUTS	FINISH: -	WEIGHT: -	RESTRICTED TO: -
CUSTOMER DRAWING		SCALE: 4:1	SHEET 1 OF 1 REV E