

WIRE READY OPT -47

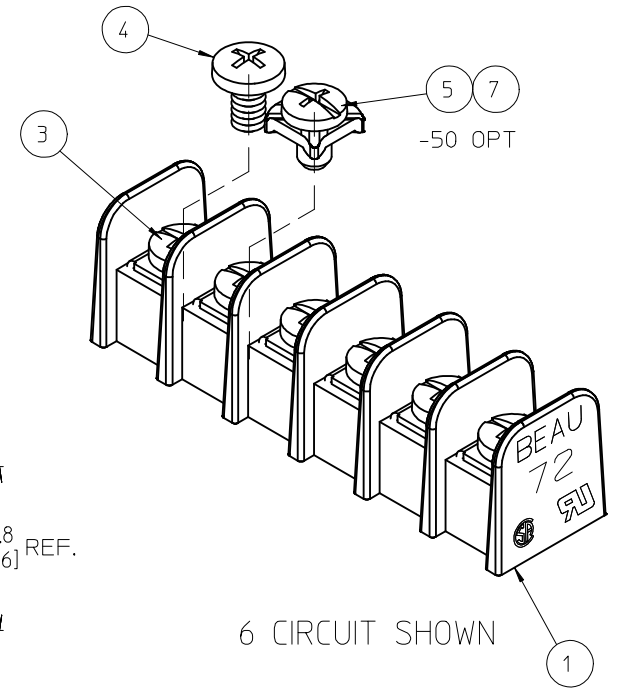
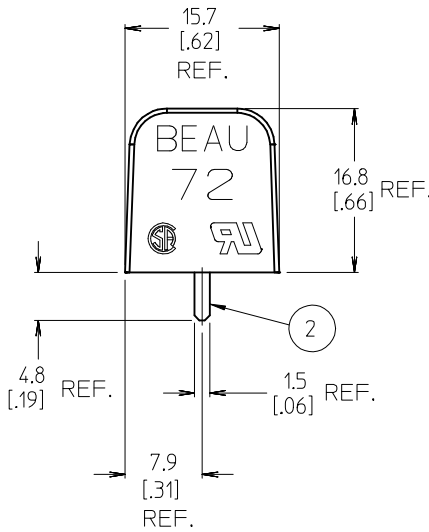
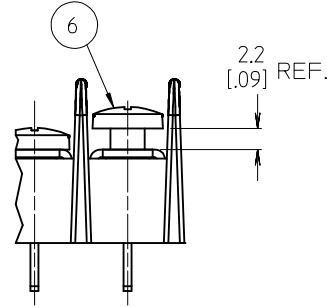

- NOTES:
1. MATERIAL: SEE TABLE
 2. FINISHES: SEE TABLE
 3. ELECTRICAL SPECIFICATIONS
 VOLTAGE RATING: 300V AC/DC
 CURRENT RATING: 15 AMPS (BINDING HD SCREW) REF.
 CURRENT RATING: 25 AMPS (WIRE CLAMP SCREW -50 OPT)
 4. WIRE RANGE: 14-22 AWG FOR BINDING HD., 12-22 AWG FOR -50 OPT
 5. SCREW TIGHTENING TORQUE: 12 IN LBS.
 6. WIRE STRIP: 7.9mm (.31 IN)
 7. OPERATING TEMP: -40°C TO +100°C
 4. PRODUCT SPEC: PS-38710-001
 5. XX REFERS TO NUMBER OF CIRCUITS

Ⓑ REF. THIS DRAWING SUPERSEDES CADKEY DOC SD-38720-002, REV-A

ITEM	QTY	DESCRIPTION	MATERIAL	FINISH
7	XX	6-32 PHSL SCR W/WSHR, NOKROM (-50-92 OPT)	STEEL	ZINC/NOKROM PLATED
6	XX	6-32 BHD PHIL-SLOT SCR, WRD (-47 OPTION)	BRASS	NICKEL PLATED
5	XX	6-32 PHSL SCR W/WSHR (-50 OPTION)	STEEL	ZINC PLATED
4	XX	6-32 BHD PHIL-SLOTTED SCREW (-49 OPTION)	BRASS	NICKEL PLATED
3	XX	6-32 SCREW PHIL.-SLOTTED (STANDARD)	STEEL	ZINC PLATED
2	XX	TERMINAL	BRASS	TIN PLATED
1	1	BARRIER	PBT	BLACK

REDRAWN & REVISED
 SEE SHEET 2
 EC NO: IPGZ016-0979
 DRW:HRSTONE 2016/01/11
 CHKD:MZIELINSKI 2016/01/14
 APPR:BRUPERT 2016/01/13

QUALITY SYMBOLS
 ▽=0
 ▽=0

GENERAL TOLERANCES (UNLESS SPECIFIED)	
mm	INCH
4 PLACES ± ---	± ---
3 PLACES ± ---	± ---
2 PLACES ± ---	± .01
1 PLACE ± 0.3	± ---
0 PLACE ± ---	± ---

ANGULAR ± 1°
 DRAFT WHERE APPLICABLE
 MUST REMAIN WITHIN DIMENSIONS

DIMENSION STYLE	
MM/IN	
DRAWN BY	DATE
RSTONE	2016/01/11
CHECKED BY	DATE
MZIELINSKI	2016/01/14
APPROVED BY	DATE
BRUPERT	2016/01/13

SCALE	DESIGN UNITS	THIRD ANGLE PROJECTION
1:10	INCH	⊙ □
9.53MM [0.375] SR BTS PC ASSY, NO MTG		
molex		
MATERIAL NO.	DOCUMENT NO.	SHEET NO.
SEE SHEET 2	SD-38720-002	1 OF 2

THIS DRAWING CONTAINS INFORMATION THAT IS PROPRIETARY TO MOLEX INCORPORATED AND SHOULD NOT BE USED WITHOUT WRITTEN PERMISSION

MATERIAL NO. (OPT -C,-50-92)	MATERIAL NO. (OPT -C,-47)	MATERIAL NO. (OPT -C,-50)	MATERIAL NO. (OPT -C,-49)	MATERIAL NO. (OPT -C)	MATERIAL NO. (INSULATOR)	NUMBER OF CIRCUITS "XX"	DIM. "A"	TOL 0.25/[±.010]	DIM. "B"
	38720-8102	38720-7502	38720-6902	38720-6302	38728-0035	02	21.1	[.83]	9.53 [1.375]
38729-1348	38720-8103	38720-7503	38720-6903	38720-6303	38728-0036	03	30.7	[1.21]	19.05 [1.750]
38729-1349	38720-8104	38720-7504	38720-6904	38720-6304	38728-0037	04	40.1	[1.58]	28.58 [1.125]
38729-1350	38720-8105	38720-7505	38720-6905	38720-6305	38728-0038	05	49.8	[1.96]	38.10 [1.500]
	38720-8106	38720-7506	38720-6906	38720-6306	38728-0039	06	59.2	[2.33]	47.63 [1.875]
	38720-8107	38720-7507	38720-6907	38720-6307	38728-0040	07	68.8	[2.71]	57.15 [2.250]
	38720-8108	38720-7508	38720-6908	38720-6308	38728-0041	08	78.3	[3.08]	66.68 [2.625]
	38720-8109	38720-7509	38720-6909	38720-6309	38728-0042	09	87.8	[3.46]	76.20 [3.000]
	38720-8110	38720-7510	38720-6910	38720-6310	38728-0043	10	97.3	[3.83]	85.73 [3.375]
38729-1495	38720-8111	38720-7511	38720-6911	38720-6311	38728-0044	11	106.9	[4.21]	95.25 [3.750]
38729-1351	38720-8112	38720-7512	38720-6912	38720-6312	38728-0045	12	116.3	[4.58]	104.78 [4.125]
	38720-8113	38720-7513	38720-6913	38720-6313	38728-0046	13	126.0	[4.96]	114.30 [4.500]
38729-1346	38720-8114	38720-7514	38720-6914	38720-6314	38728-0047	14	135.3	[5.33]	123.83 [4.875]
38729-1352	38720-8115	38720-7515	38720-6915	38720-6315	38728-0048	15	145.0	[5.71]	133.35 [5.250]
38729-1353	38720-8116	38720-7516	38720-6916	38720-6316	38728-0049	16	154.4	[6.08]	142.88 [5.625]
	38720-8117	38720-7517	38720-6917	38720-6317	38728-0050	17	164.1	[6.46]	152.40 [6.000]
	38720-8118	38720-7518	38720-6918	38720-6318	38728-0051	18	173.5	[6.83]	161.93 [6.375]
	38720-8119	38720-7519	38720-6919	38720-6319	38728-0052	19	183.1	[7.21]	171.45 [6.750]
	38720-8120	38720-7520	38720-6920	38720-6320	38728-0053	20	192.5	[7.58]	180.98 [7.125]
38729-1347	38720-8121	38720-7521	38720-6921	38720-6321	38728-0054	21	202.2	[7.96]	190.50 [7.500]
	38720-8122	38720-7522	38720-6922	38720-6322	38728-0055	22	211.6	[8.33]	200.03 [7.875]
	38720-8123	38720-7523	38720-6923	38720-6323	38728-0056	23	221.2	[8.71]	209.55 [8.250]
	38720-8124	38720-7524	38720-6924	38720-6324	38728-0057	24	230.6	[9.08]	219.08 [8.625]
	38720-8125	38720-7525	38720-6925	38720-6325	38728-0058	25	240.3	[9.46]	228.60 [9.000]
	38720-8126	38720-7526	38720-6926	38720-6326	38728-0059	26	249.6	[9.83]	238.13 [9.375]

PTH PATTERN

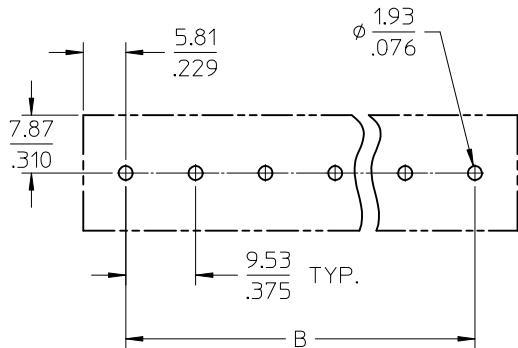

ADD PINS TO TABLE ELEC MFG DOC: 2016/01/11 DRW:RSTONE 2016/01/14 CHK:HZ/EL/INSKI 2016/01/13 APPR:BRUPERT	DESCRIPTION REV B	QUALITY SYMBOLS ▽=0 ▽=0	GENERAL TOLERANCES (UNLESS SPECIFIED) mm INCH 4 PLACES ± --- ± --- 3 PLACES ± --- ± --- 2 PLACES ± --- ± .01 1 PLACE ± 0.3 ± --- 0 PLACE ± --- ± ---	DIMENSION STYLE MM/IN DRAWN BY DATE RSTONE 2016/01/11 CHECKED BY DATE MZIEL INSKI 2016/01/14 APPROVED BY DATE BRUPERT 2016/01/13	SCALE 1:1 DESIGN UNITS INCH THIRD ANGLE PROJECTION	TITLE 9.53MM [.375] SR BTS PC ASSY, NO MTG
		ANGULAR ± 1 ° DRAFT WHERE APPLICABLE MUST REMAIN WITHIN DIMENSIONS	MATERIAL NO. -	DOCUMENT NO. SD-38720-002	SHEET NO. 2 OF 2	
		THIS DRAWING CONTAINS INFORMATION THAT IS PROPRIETARY TO MOLEX INCORPORATED AND SHOULD NOT BE USED WITHOUT WRITTEN PERMISSION				
		SIZE B				