

Specification

Part Number: TM141044

Description: Omni-Directional Electret Condenser Microphone

(Size 9.7mm x 4.5mm)

RoHS Compliant

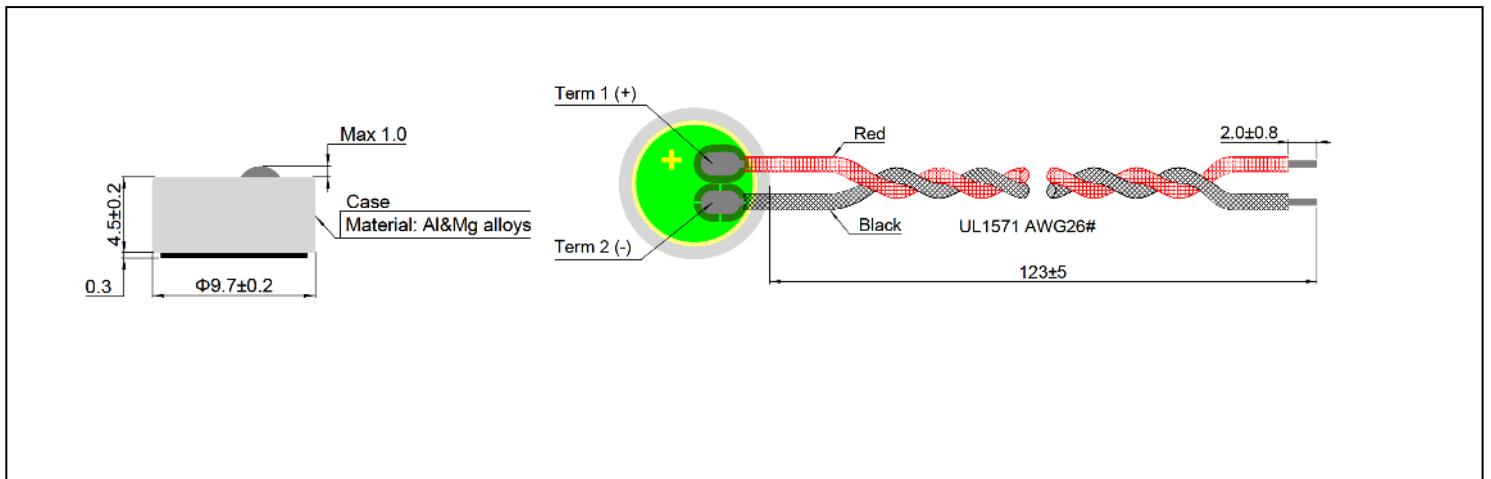

Revision	Date	Comments
A	July 29, 2018	Initial Release

1. ELECTRICAL SPECIFICATIONS

Standard Conditions		Basic Test Conditions	
Temperature	5 to 35°C	Temperature	20 ± 2°C
Humidity	45 to 85%	Humidity	63 to 67%
Air Pressure	86 to 106kPa	Air Pressure	86 to 106kPa

Parameter	SPEC	Unit
Directional Characteristic	Omni Directional	—
Sensitivity	-40±3	dB
Impedance	1.5(Max)	kΩ
S/N Ratio (A weighted network)	60(typical)	dB
Maximum Input Sound Pressure Level	110 THD≤3%	dB
Standard Operating Voltage	5.0	Vdc
Operating Voltage Range	1.0~10	Vdc
Decrease Voltage Characteristics (Vs=2.0 to 1.5V dc)	-3(Max)	dB
Current Consumption	500	μA
Standard Test Circuit	See Fig. 1	—
Frequency Response Characteristic	See Fig. 2	—
Memo	Standard test condition	RL=1.5kΩ, Vs=5.0V dc (@f=1kHz, Pin=1Pa, 0dB=1V/Pa,L=50cm)

2. STANDARD TEST CIRCUIT

Fig.1

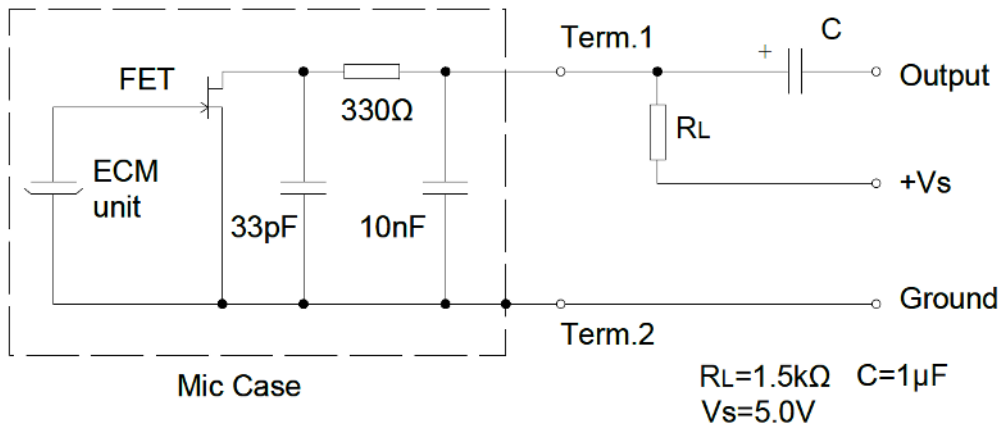

3. TYPICAL FREQUENCY RESPONSE

Fig.2

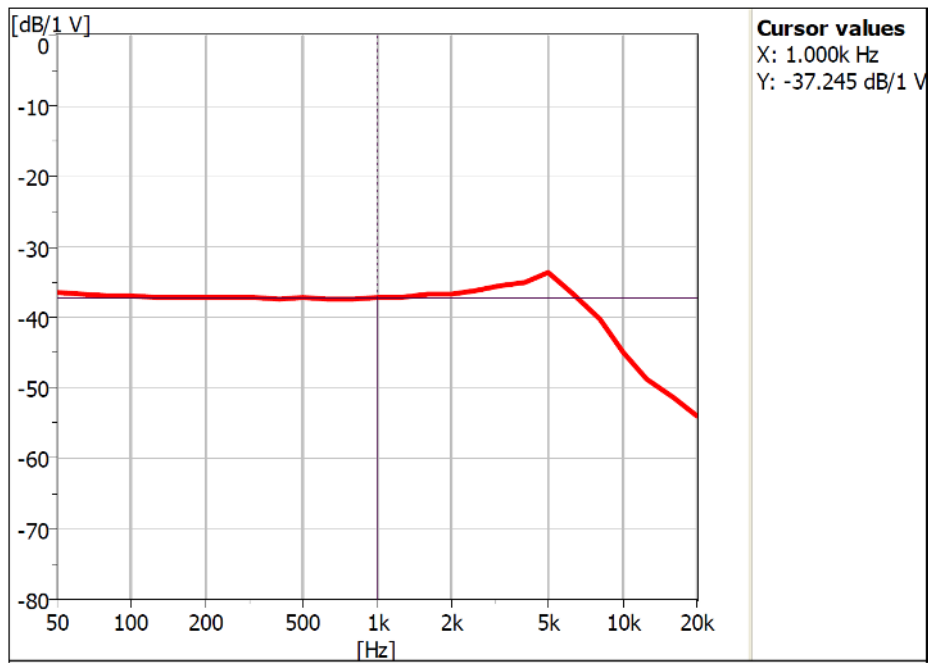

4. RELIABILITY

Item		Test conditions	Evaluation standard
1	Hi-Temp.Test	The microphone unit must be subjected to +80°C for 100 hours and exposed to room temperature for 3 hours.	After any of the tests, the sensitivity of the microphone unit shall not change more than ± 3 dB from initial value and shall keep its initial operation and appearance.
2	Low-Temp.Test	The microphone unit must be subjected to -40°C for 100 hours and exposed to room temperature for 3 hours.	
3	Humidity &Heat Test	The microphone unit must be subjected to +55°C, 85% RH-for 100 hours and exposed to room temp for 3 hours.	
4	Thermal Shock Test	The microphone unit must be subjected to following condition [+80°C 0.5H → room temp 1H→ -40°C 0.5H →room temp 1H]at 10 cycles and exposed to room temp for 3 hours	
5	Vibration Test	The microphone unit must be subjected to a procedure that it is vibrating for two hours from each of the three directions(x y z) with a frequency of 10-55Hz and a 1.52mm-high amplitude.	
6	Drop Test	The microphone unit must be subjected to a procedure that it is dropped on a slippery marble floor for 5 times from a 1.0-meter-height without package.	
7	Storage Temperature	-30°C~+60°C	
8	Operating Temperature	30°C~+60°C	

Additional Notes

- 1) All the soldering procedures upon microphones must be completed in a heat sink device. The temperature of the soldering iron must be limited to 360°C±10°C and the soldering time should not exceed 3 seconds.
- 2) Operators, the soldering fixture and the soldering iron must be statically grounded under each soldering process.