

NUMBER
C-1734069

3RD ANGLE PROJECTION

METRIC

THIS INFORMATION IS CONFIDENTIAL AND IS DISCLOSED TO YOU ON CONDITION THAT NO FURTHER DISCLOSURE IS MADE BY YOU TO OTHER THAN AMP PERSONNEL WITHOUT WRITTEN AUTHORIZATION FROM AMP (TAIWAN) LTD. DIMENSIONS IN MILLIMETERS. DO NOT SCALE PRINT.

PRINT
DW

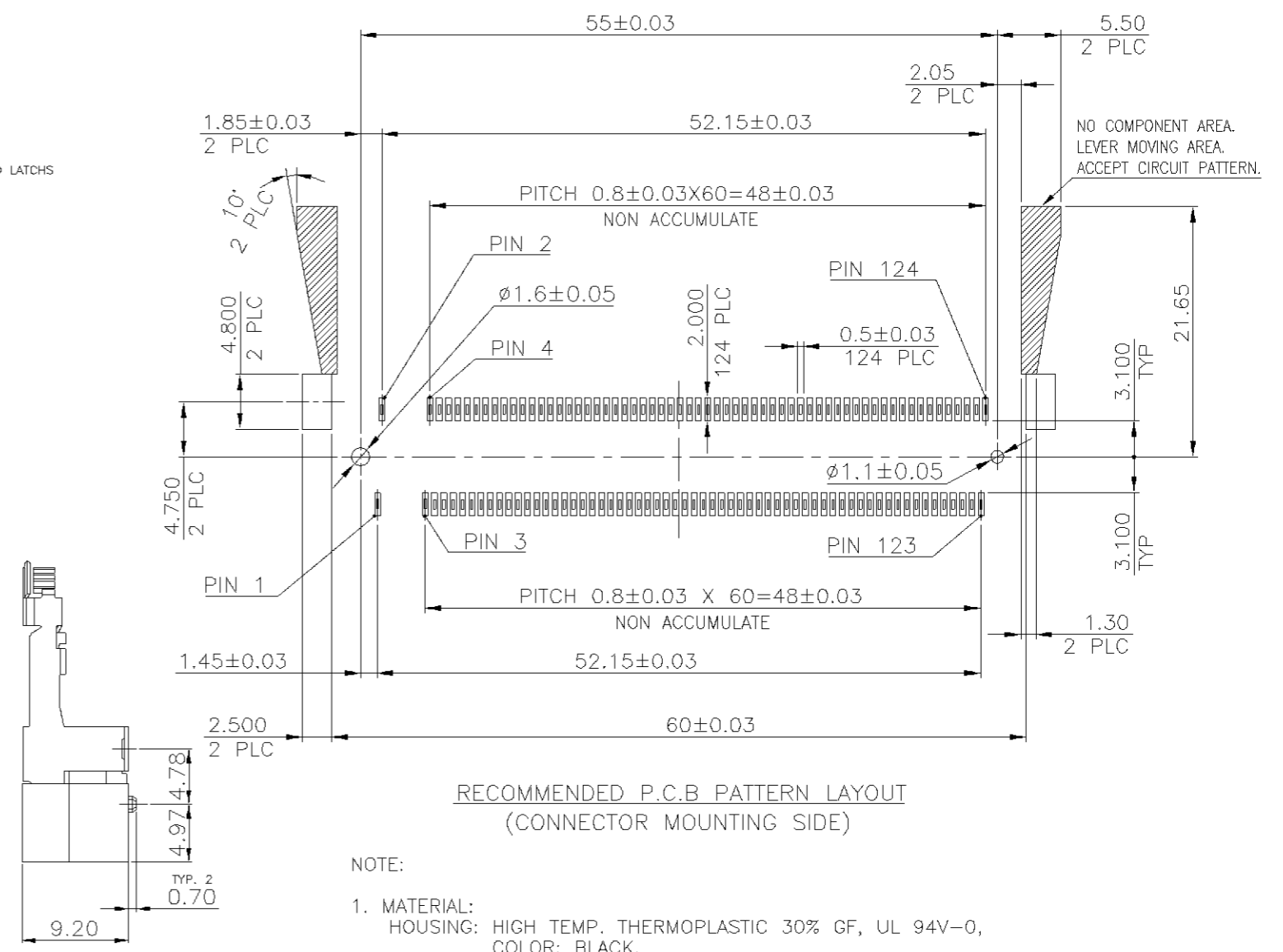
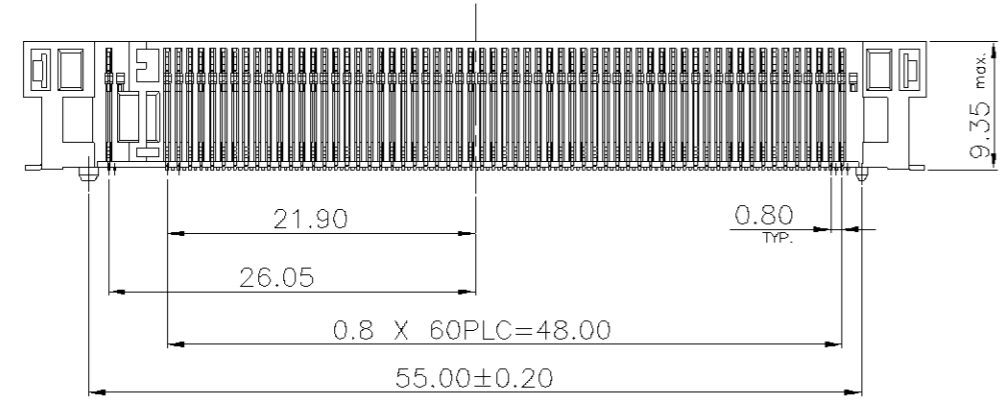
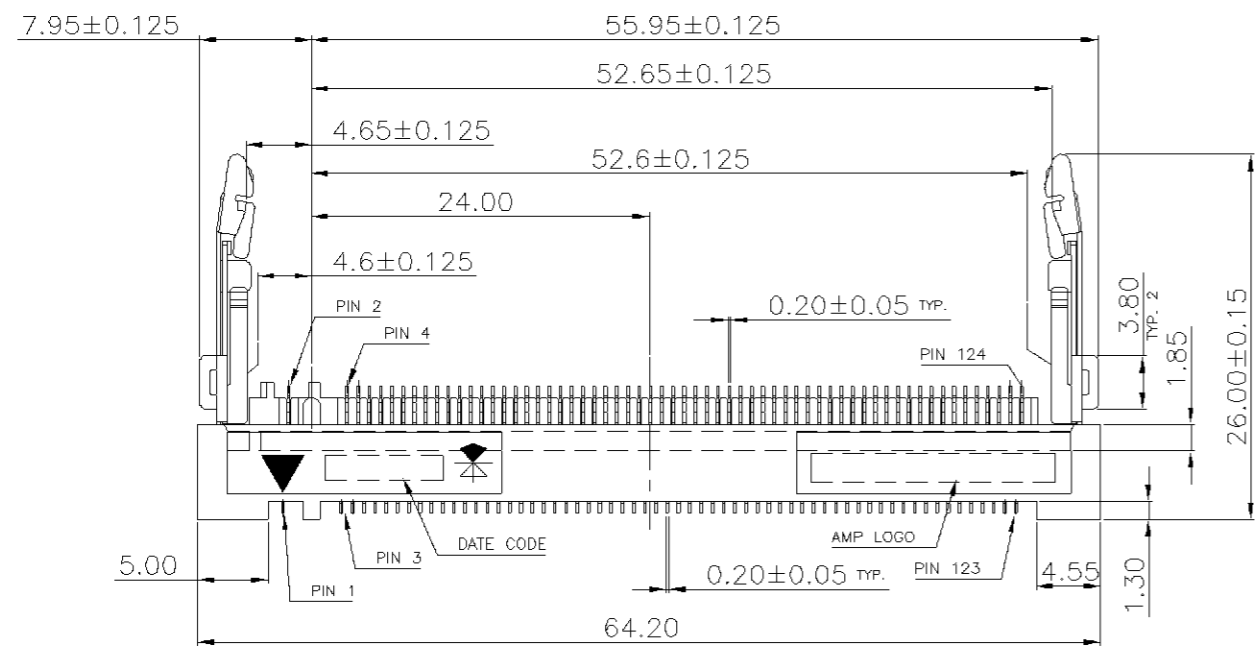
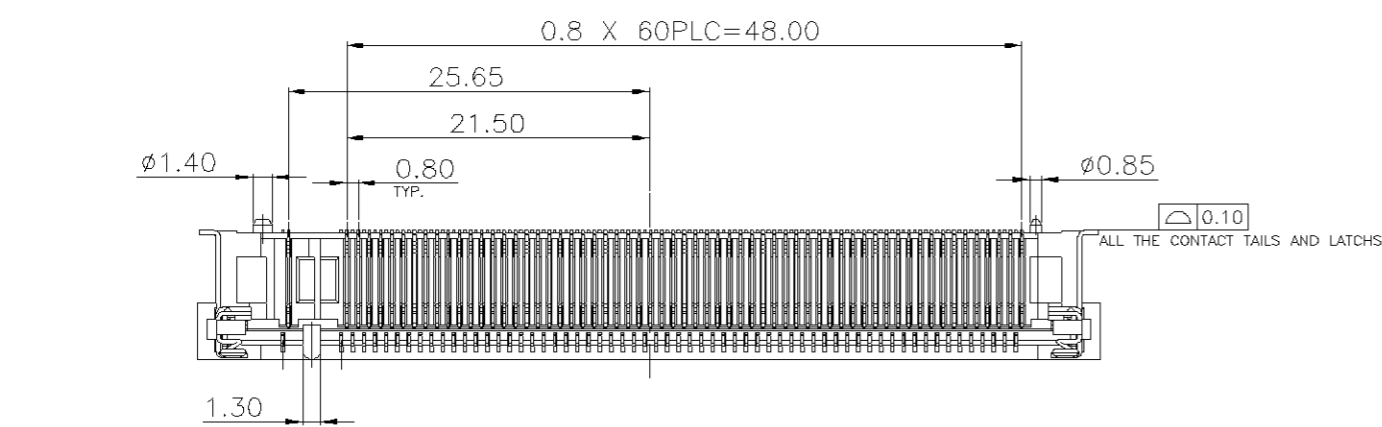

RECOMMENDED P.C.B. PATTERN LAYOUT
(CONNECTOR MOUNTING SIDE)

- NOTE:
- MATERIAL:
HOUSING: HIGH TEMP. THERMOPLASTIC 30% GF, UL 94V-0, COLOR: BLACK.
CONTACTS: PHOSPHOR BRONZE.
LATCHES: STAINLESS STEEL.
 - FINISH:
CONTACTS: 5μ" MIN. GOLD PLATED IN CONTACT AREA, 100μ" MIN. TIN(MATTE) OVER 50μ" MIN. NICKEL ON SOLDER TAIL.
50μ" MIN. NICKEL UNDERPLATED ALL OVER.
LATCHES: 100μ" MIN. TIN (MATTE) OVER 50μ" MIN. NICKEL.
 - PRODUCT NET WEIGHT: 6.4g/PC.

	TAPE REEL	1734069-3
NO PRODUCTION	TRAY	1734069-2
	HARD TRAY	1734069-1
	PACKAGE TYPE	PART NUMBER

TOLERANCES UNLESS OTHERWISE SPECIFIED: 0 PLC ±0.25 1 PLC ±0.15 2 PLC ±0.1 3 PLC ±0.05 ANGLES ±2'	DWN J. LEE 11-JUN-2004	tyco TYCO HOLDINGS (BERMUDA) Electronics VII LTD. TAIWAN BRANCH NAME
MATERIAL SEE NOTE	CHK S. HOU 11-JUN-2004	
FINISH SEE NOTE	APVD W.J. KE 11-JUN-2004	0.8 PITCH MINI PCI SOCKET, 9.2 HEIGHT, 124 POSITION
	PRODUCT SPEC 108-57380	LOC DW
	APPLICATION SPEC -	SIZE A ₃
	WEIGHT	DRAWING NO C-1734069
		REV 0
		SCALE --
		SHEET 1 OF 6

O	FIRST RELEASED	FZ00-0113-04	JL SH	11JUN 2004
LTR	REVISION RECORD	ECN	DWN CHK	DATE

THIS INFORMATION IS CONFIDENTIAL AND IS DISCLOSED TO YOU ON CONDITION THAT NO FURTHER DISCLOSURE IS MADE BY YOU TO OTHER THAN AMP PERSONNEL WITHOUT WRITTEN AUTHORIZATION FROM AMP (TAIWAN) LTD. DIMENSIONS IN MILLIMETERS. DO NOT SCALE PRINT.

PRINT DIST
DW

METRIC

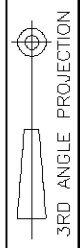

NUMBER
C-1734069

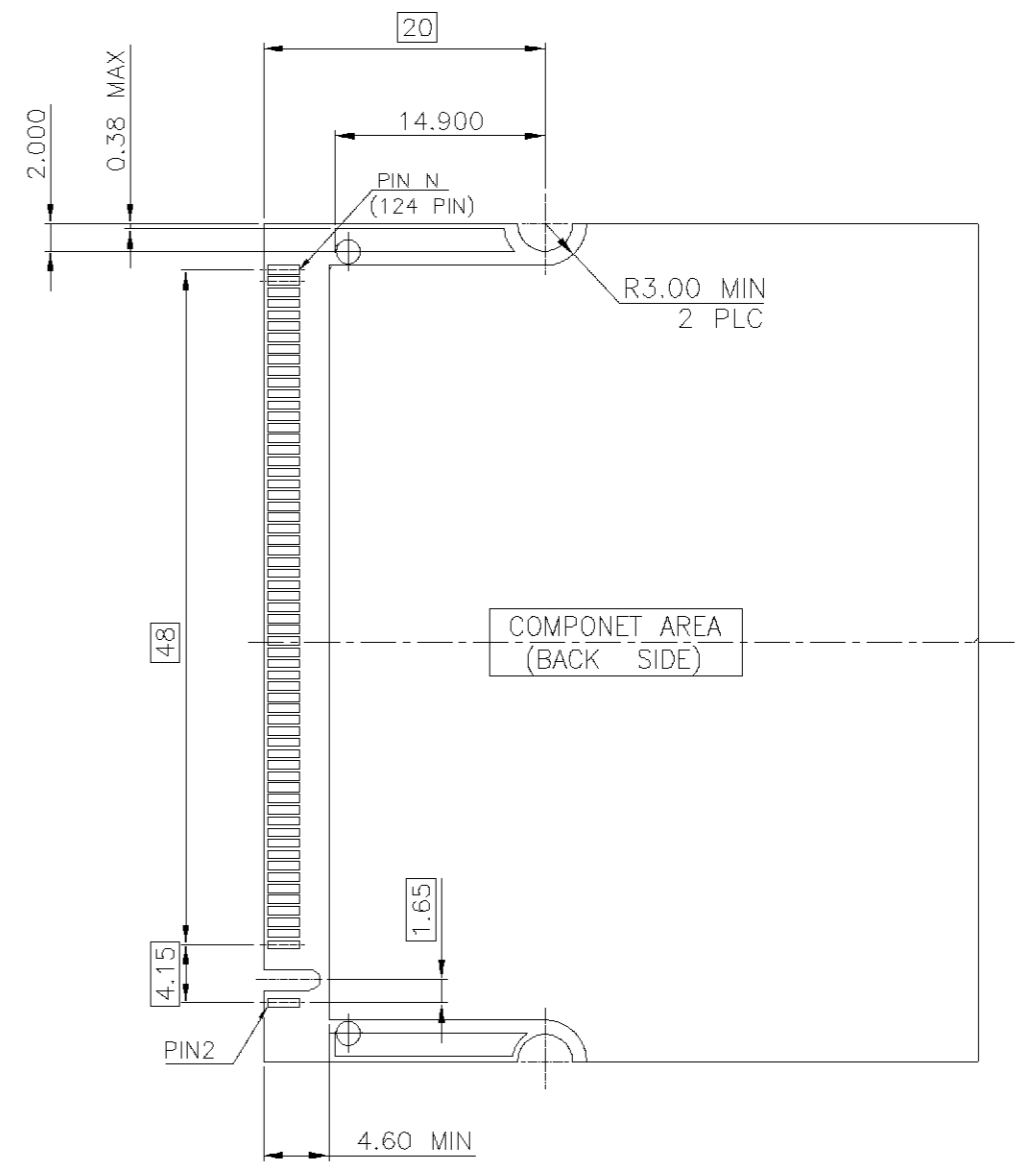
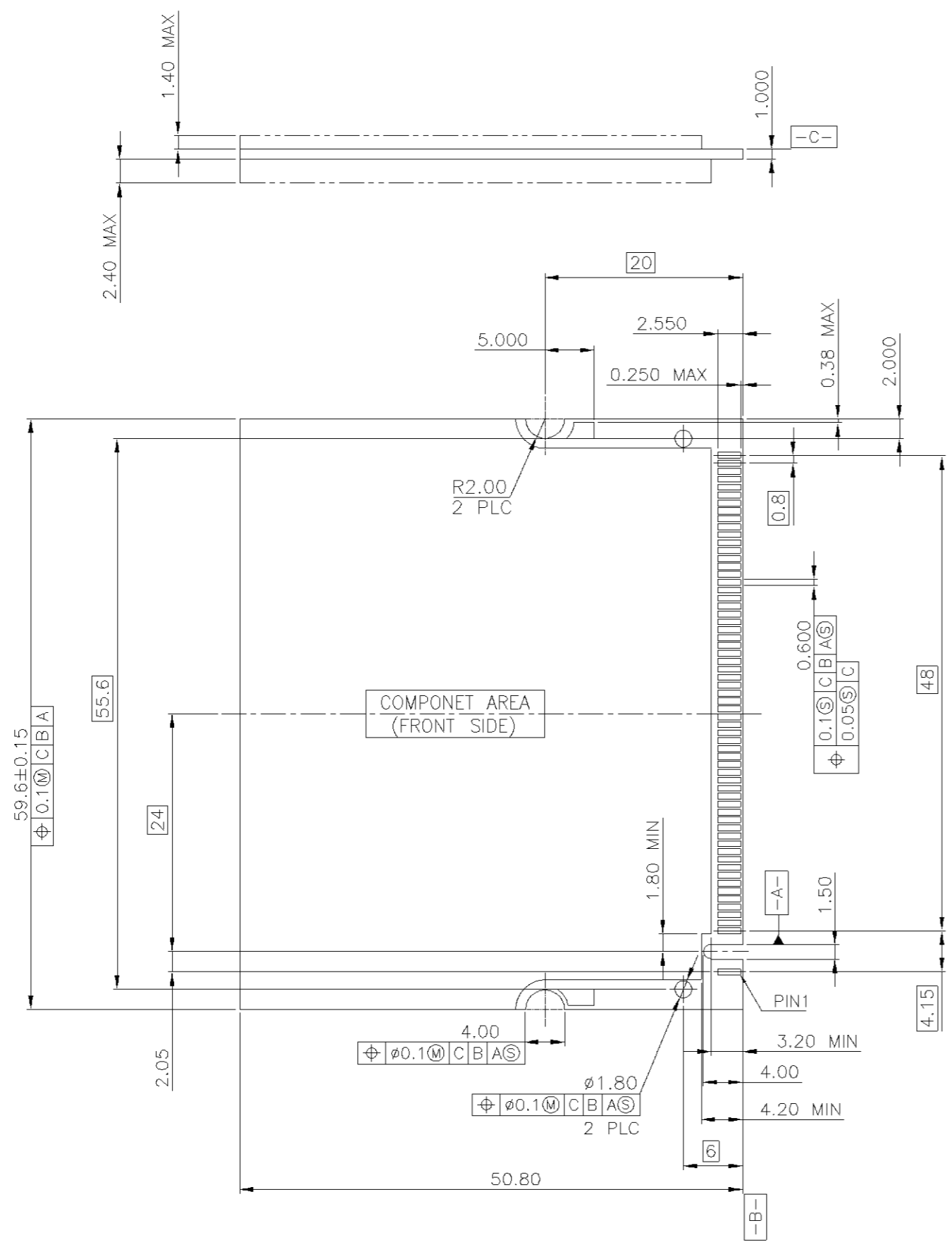

TOLERANCES UNLESS OTHERWISE SPECIFIED:		DWN		J. LEE		tyco		TYCO HOLDINGS (BERMUDA)	
0 PLC ±0.25		11-JUN-2004		S. HOU		Electronics		VII LTD. TAIWAN BRANCH	
1 PLC ±0.15		11-JUN-2004		W.J. KE		NAME		0.8 PITCH MINI PCI SOCKET, 9.2 HEIGHT, 124 POSITION	
2 PLC ±0.1		11-JUN-2004		11-JUN-2004		APVD		LOC	
3 PLC ±0.05		11-JUN-2004		11-JUN-2004		PRODUCT SPEC		SIZE	
ANGLES ±2'		11-JUN-2004		11-JUN-2004		APPLICATION SPEC		DRAWING NO	
MATERIAL		-		-		WEIGHT		REV	
FINISH		-		-		SCALE		C-1734069	
-		-		-		SHEET		0	
-		-		-		2 OF 6		-	

SEE SHEET 1.	ECN	DWN	CHK	DATE
LTR	REVISION RECORD			

NUMBER
C-1734069

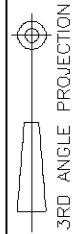

METRIC

THIS INFORMATION IS CONFIDENTIAL AND IS DISCLOSED TO YOU ON CONDITION THAT NO FURTHER DISCLOSURE IS MADE BY YOU TO OTHER THAN AMP PERSONNEL WITHOUT WRITTEN AUTHORIZATION FROM AMP (TAIWAN) LTD. DIMENSIONS IN MILLIMETERS. DO NOT SCALE PRINT.

PRINT DIST
DW

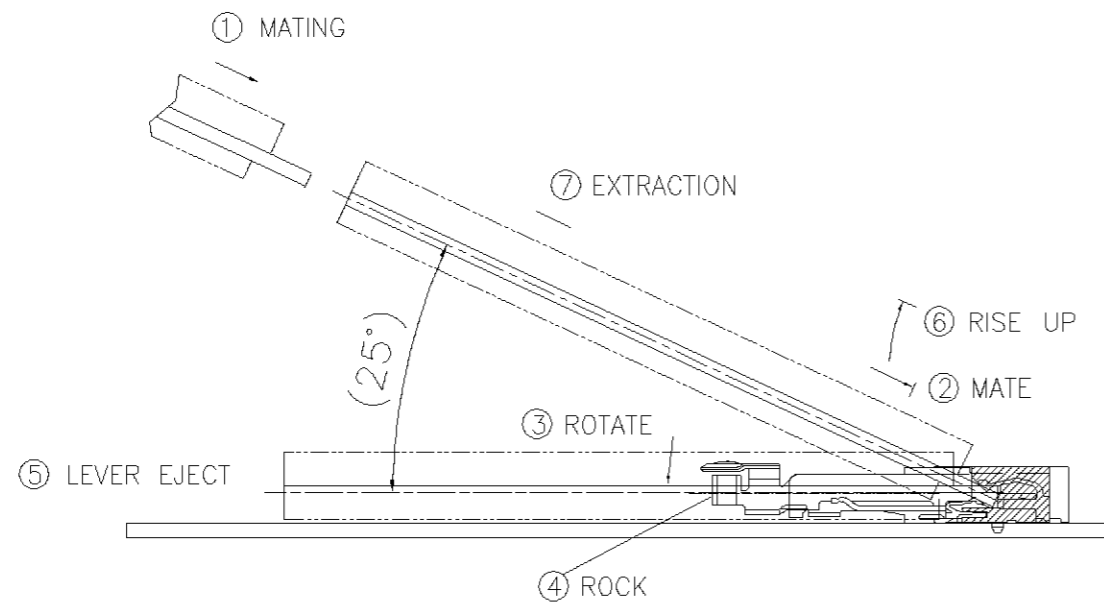
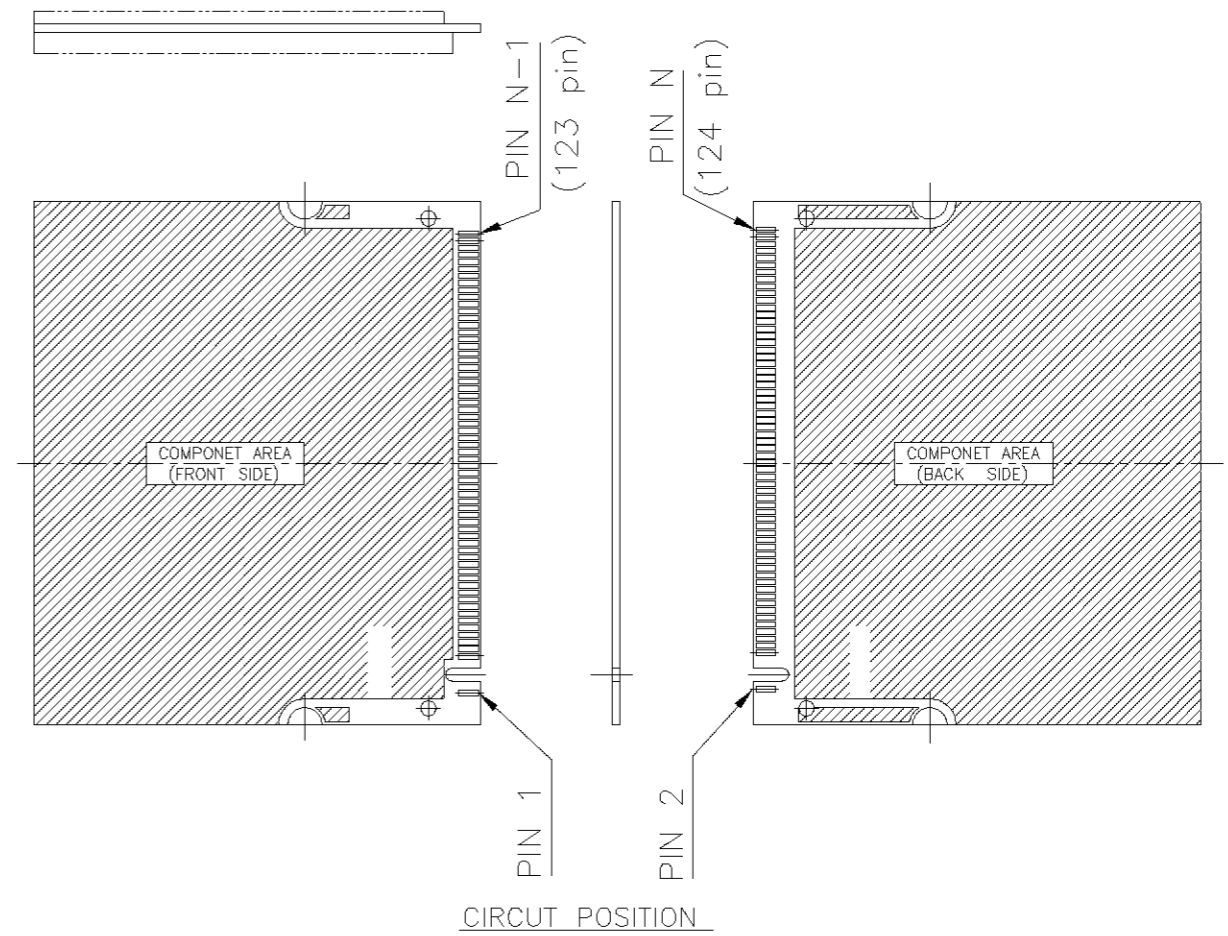
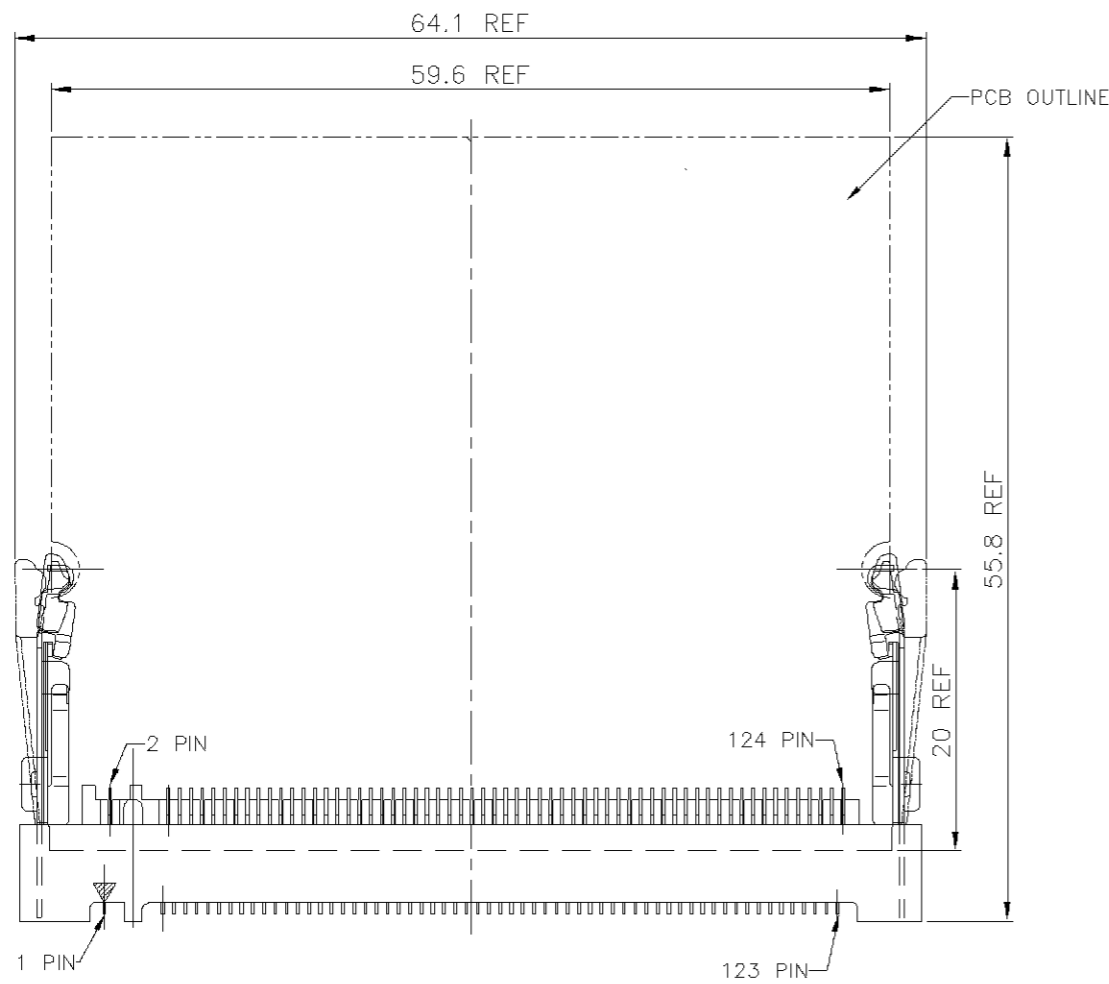

HOW TO MATE AND UNMATE

MATE: ① ~ ④
UNMATE: ⑤ ~ ⑦

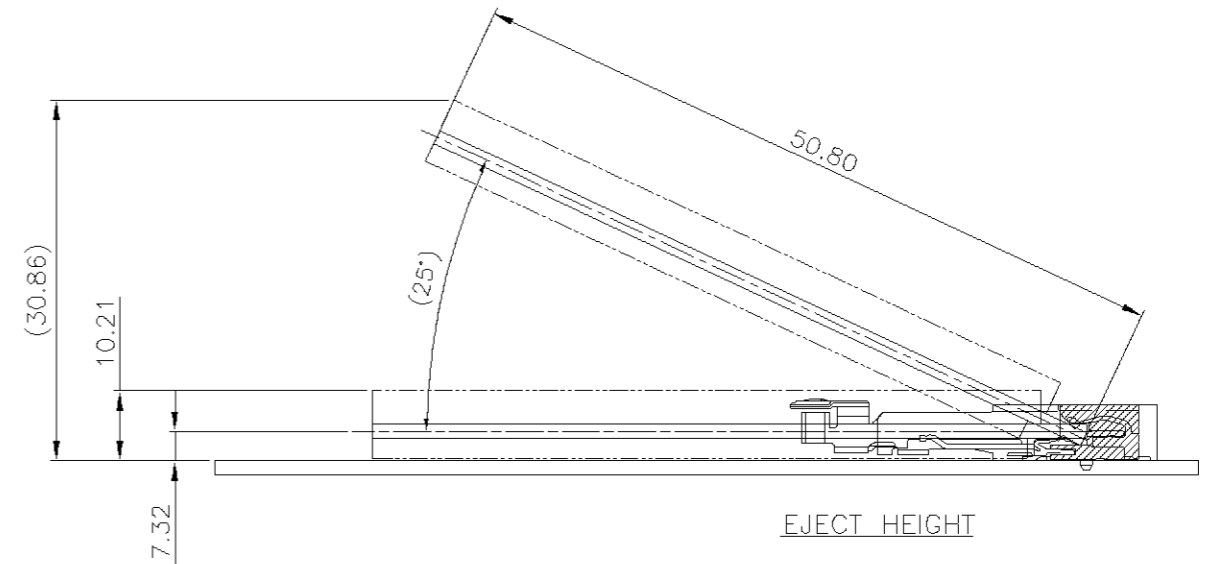

TOLERANCES UNLESS OTHERWISE SPECIFIED:		DWN	J. LEE	tyco TYCO HOLDINGS (BERMUDA) VII LTD. TAIWAN BRANCH
0 PLC	±0.25	CHK	S. HOU	
1 PLC	±0.15	11-JUN-2004		NAME
2 PLC	±0.1	11-JUN-2004		
3 PLC	±0.05	11-JUN-2004		0.8 PITCH MINI PCI SOCKET, 9.2 HEIGHT, 124 POSITION
ANGLES	±2'	11-JUN-2004		
MATERIAL	-	APVD	W.J. KE	LOC SIZE DRAWING NO REV DW A ₃ C-1734069 0
FINISH	-	PRODUCT SPEC	11-JUN-2004	
		APPLICATION SPEC		SCALE SHEET -- 3 OF 6
		WEIGHT		

SEE SHEET 1.	ECN	DWN	CHK	DATE
LTR	REVISION RECORD			

CUSTOMER DRAWING

NUMBER
C-1734069

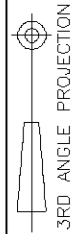

METRIC

THIS INFORMATION IS CONFIDENTIAL AND IS DISCLOSED TO YOU ON CONDITION THAT NO FURTHER DISCLOSURE IS MADE BY YOU TO OTHER THAN AMP PERSONNEL WITHOUT WRITTEN AUTHORIZATION FROM AMP (TAIWAN) LTD. DIMENSIONS IN MILLIMETERS. DO NOT SCALE PRINT.

PRINT DIST
DW

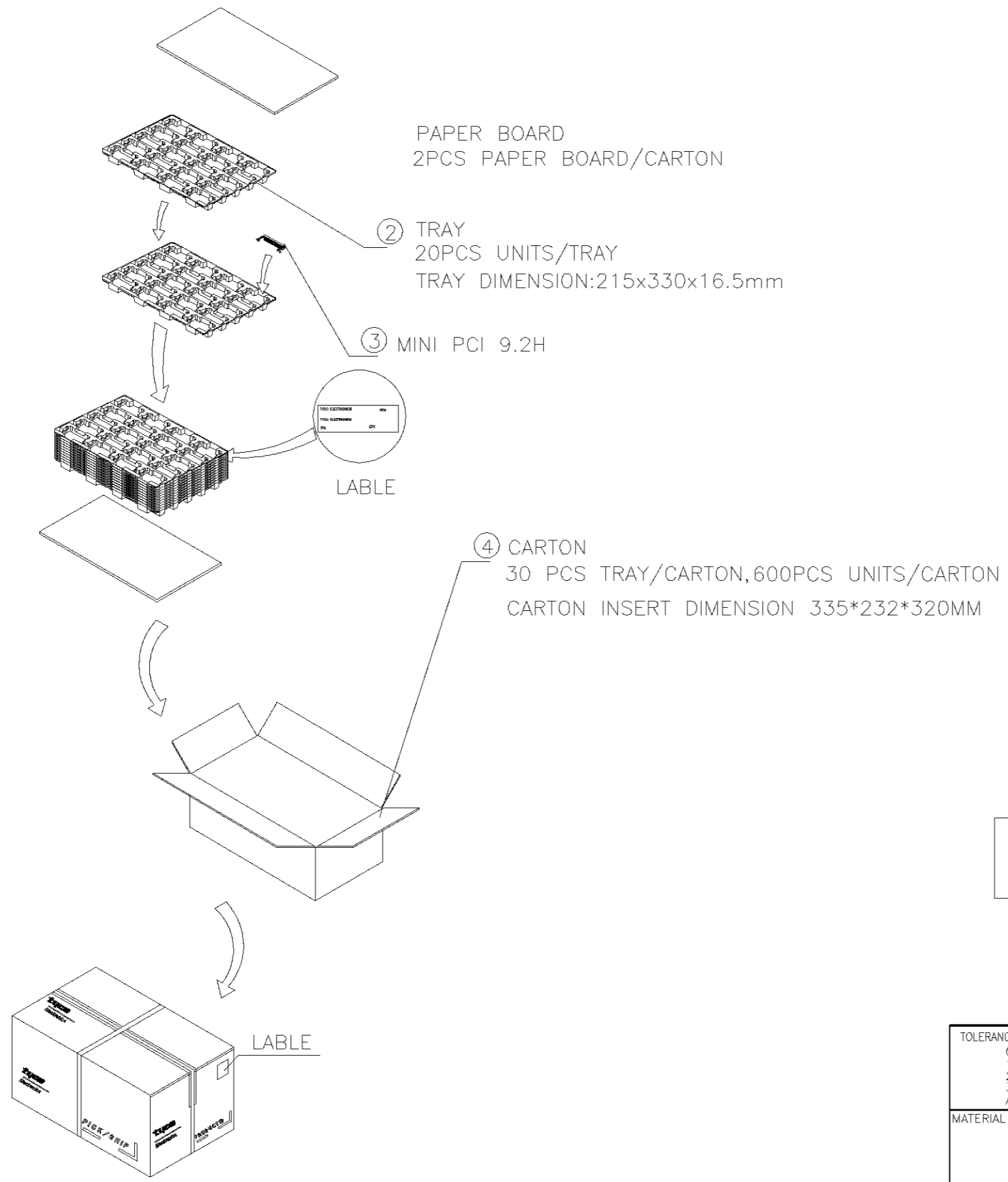

NOTES:

1. TRAYA MATERIAL: PS, CLEAR CLEAR
2. PRIMARY PACKING: 600PCS/CARTON
3. SECONDARY PACKING: 20PCS/TRAY
4. NET WEIGHT: 6.4g/PC UNIT.
128g/TRAY, 3.84kg/CARTON
5. GROSS WEIGHT: 5.5Kg/CARTON.

FOR 1734069-2

TOLERANCES UNLESS OTHERWISE SPECIFIED: 0 PLC ± 1 PLC ± 2 PLC ± 3 PLC ± ANGLES ±	DWN	J. LEE 11-JUN-2004	TYCO HOLDINGS (BERMUDA) VII LTD. TAIWAN BRANCH
	CHK	S. HOU 11-JUN-2004	
MATERIAL	APVD	W.J. KE 11-JUN-2004	NAME 0.8 PITCH MINI PCI SOCKET, 9.2 HEIGHT, 124 POSITION
FINISH	PRODUCT SPEC		LOC SIZE DRAWING NO REV DW A ₃ C-1734069 0
	APPLICATION SPEC		SCALE SHEET -- 4 OF 6
	WEIGHT		

SEE SHEET 1.			
LTR	REVISION RECORD	ECN	DWN CHK DATE

NUMBER
C-1734069

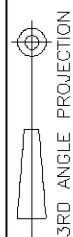

METRIC

THIS INFORMATION IS CONFIDENTIAL AND IS DISCLOSED TO YOU ON CONDITION THAT NO FURTHER DISCLOSURE IS MADE BY YOU TO OTHER THAN AMP PERSONNEL WITHOUT WRITTEN AUTHORIZATION FROM AMP (TAIWAN) LTD. DIMENSIONS IN MILLIMETERS. DO NOT SCALE PRINT.

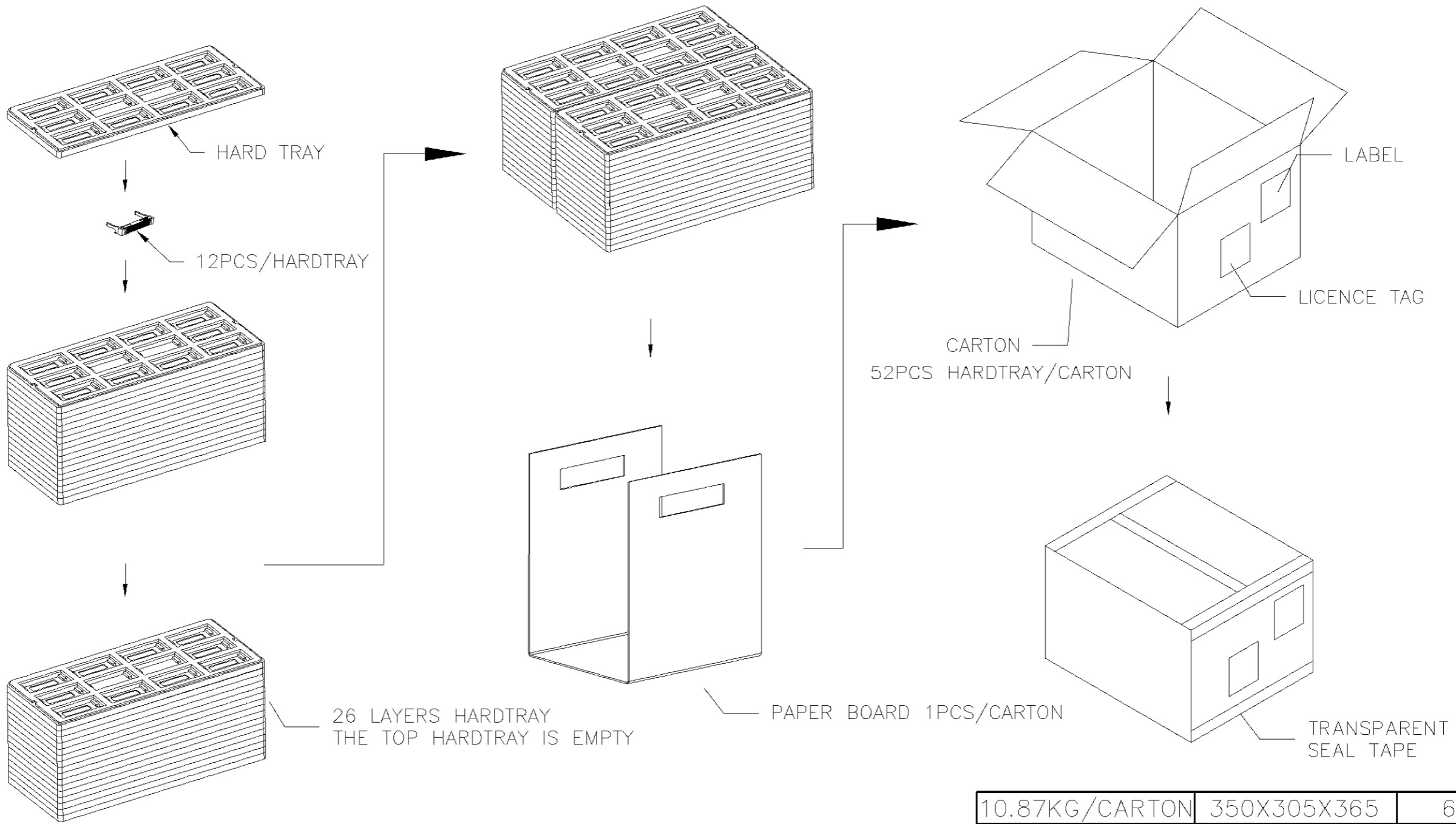

FOR 1734069-1

10.87KG/CARTON	350X305X365	600 PCS
GROSS WEIGHT	CARTON SIZE	QT'Y/CARTON

TOLERANCES UNLESS OTHERWISE SPECIFIED: 0 PLC ± 1 PLC ± 2 PLC ± 3 PLC ± ANGLES ±	DWN J. LEE 11-JUN-2004	tyco TYCO HOLDINGS (BERMUDA) Electronics VII LTD. TAIWAN BRANCH NAME
MATERIAL -	CHK S. HOU 11-JUN-2004	
FINISH -	APVD W.J. KE 11-JUN-2004	0.8 PITCH MINI PCI SOCKET, 9.2 HEIGHT, 124 POSITION.
	PRODUCT SPEC -	
	APPLICATION SPEC -	LOC SIZE DRAWING NO REV DW A ₃ C-1734069 0
	WEIGHT	SCALE SHEET -- 5 OF 6

	SEE SHEET 1.			
LTR	REVISION RECORD	ECN	DWN CHK	DATE

NUMBER
C-1734069

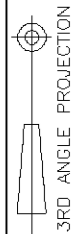

METRIC

THIS INFORMATION IS CONFIDENTIAL AND IS DISCLOSED TO YOU ON CONDITION THAT NO FURTHER DISCLOSURE IS MADE BY YOU TO OTHER THAN AMP PERSONNEL WITHOUT WRITTEN AUTHORIZATION FROM AMP (TAIWAN) LTD. DIMENSIONS IN MILLIMETERS. DO NOT SCALE PRINT.

PRINT DIST
DW

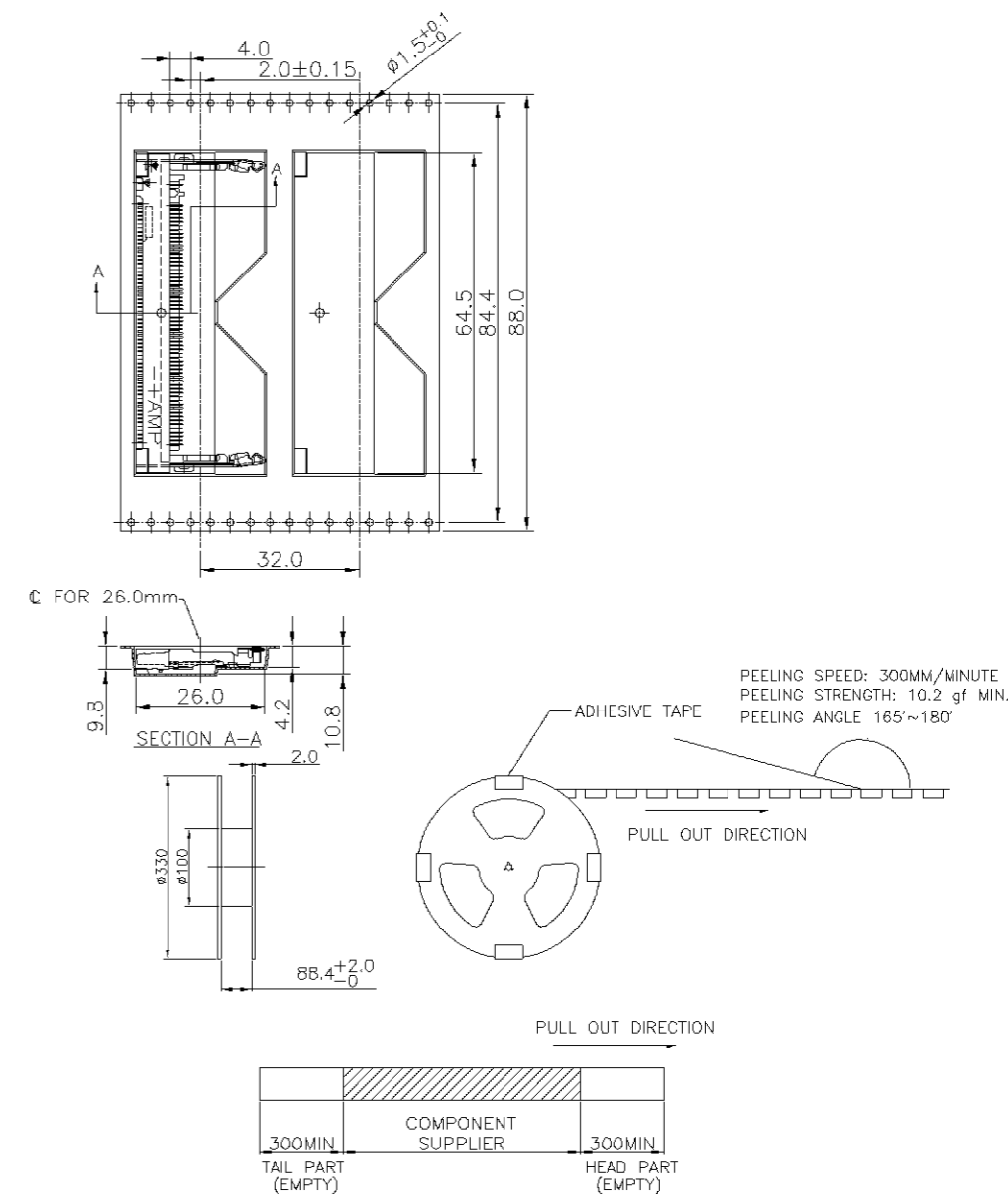
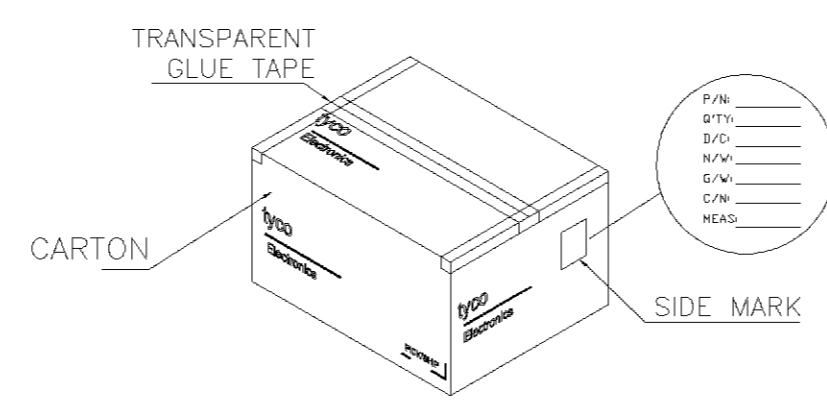
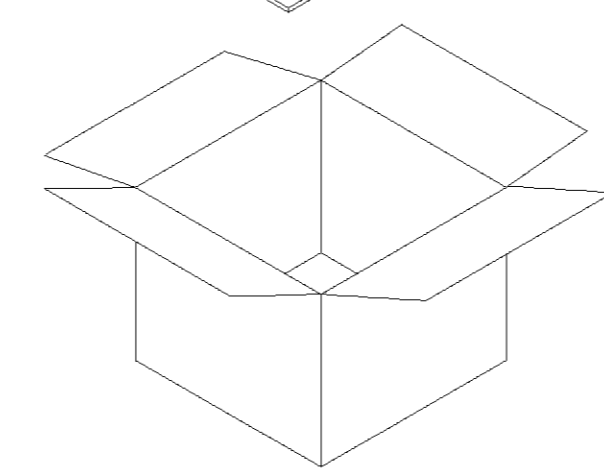
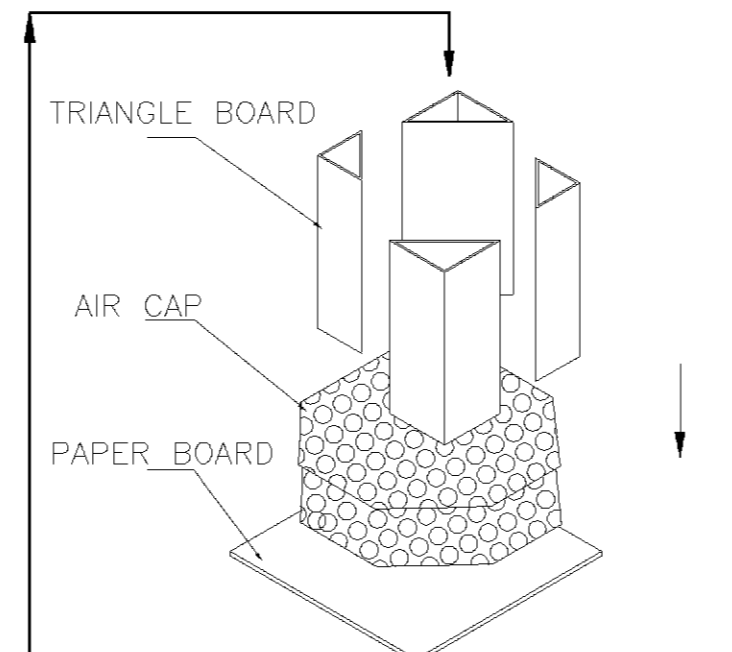
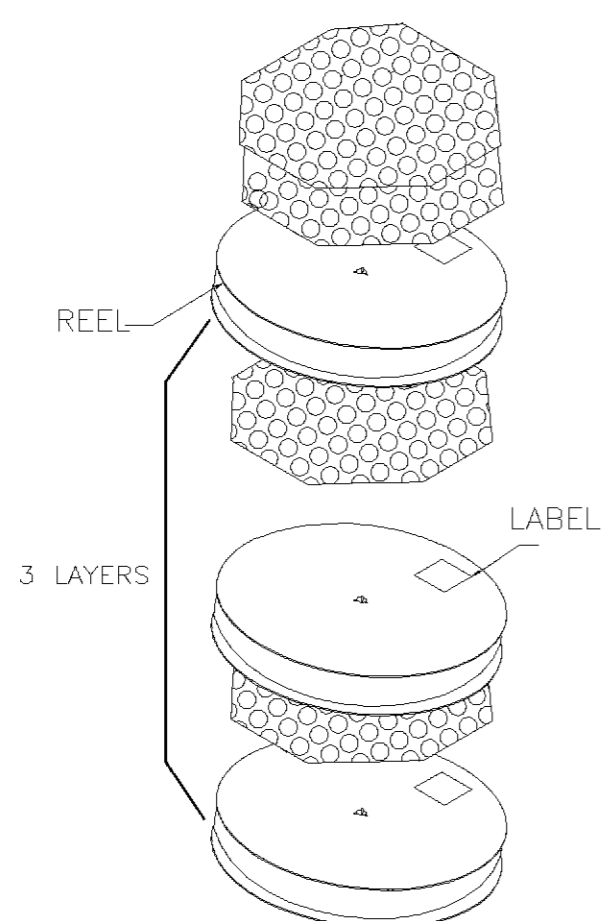

FOR 1734069-3

5.8KG/CARTON	355X355X345	450 PCS
GROSS WEIGHT	CARTON SIZE	QT'Y/CARTON

TOLERANCES UNLESS OTHERWISE SPECIFIED: 0 PLC ± 1 PLC ±0.15 2 PLC ±0.10 3 PLC ±0.05 ANGLES ±2'	DWN	J. LEE	tyco Electronics TYCO HOLDINGS (BERMUDA) VII LTD. TAIWAN BRANCH
	CHK	S. HOU	
MATERIAL	APVD	W.J. KE	NAME 0.8 PITCH MINI PCI SOCKET, 9.2 HEIGHT, 124 POSITION.
-	PRODUCT SPEC	11-JUN-2004	
FINISH	APPLICATION SPEC	-	LOC DW A ₃ DRAWING NO C-1734069 REV 0
-	WEIGHT	-	SCALE -- SHEET 6 OF 6

LTR	REVISION RECORD	ECN	DWN	CHK	DATE
	SEE SHEET 1.				