

REVISIONS					
P	LTR	DESCRIPTION	DATE	DWN	APVD
E6		RELEASED PER ECR-20-011015	12AUG2020	FDP	TD

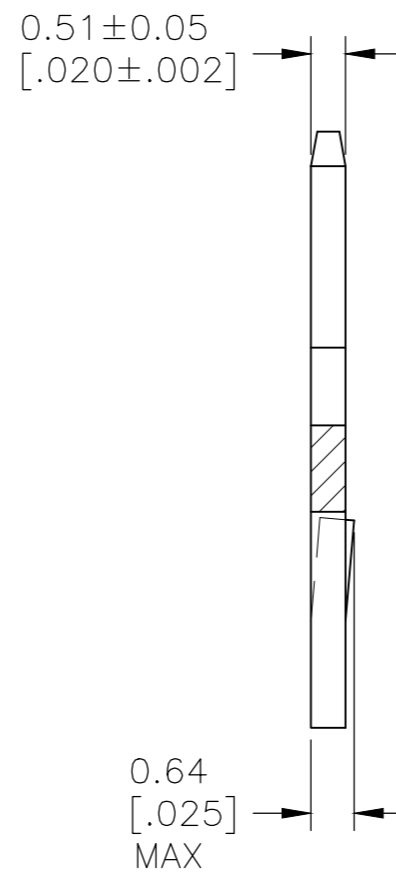

- 1 SPECIFICATIONS:  
MAGNET WIRE #18 - #34 AWG,  
1.02 [.040]-0.16 [.006] DIA COPPER.  
OTHER SIZES MAY BE ACCOMMODATED,  
CONSULT TYCO ELECTRONICS FOR APPROVAL.
- 2 POCKET RECOMMENDATION: #1601424
- 3 TERMINAL APPLICATION TO COMPLY WITH TE CONNECTIVITY SPECIFICATION 114-13166 FIGURE 5.
- 4 TWO(2) TERMINALS SHOWN FOR ILLUSTRATION PURPOSES ONLY.
- 5 HAND SOLDERING WITH SOLDER ALLOY.  
SOLDERING TEMPERATURE IS 370°C.

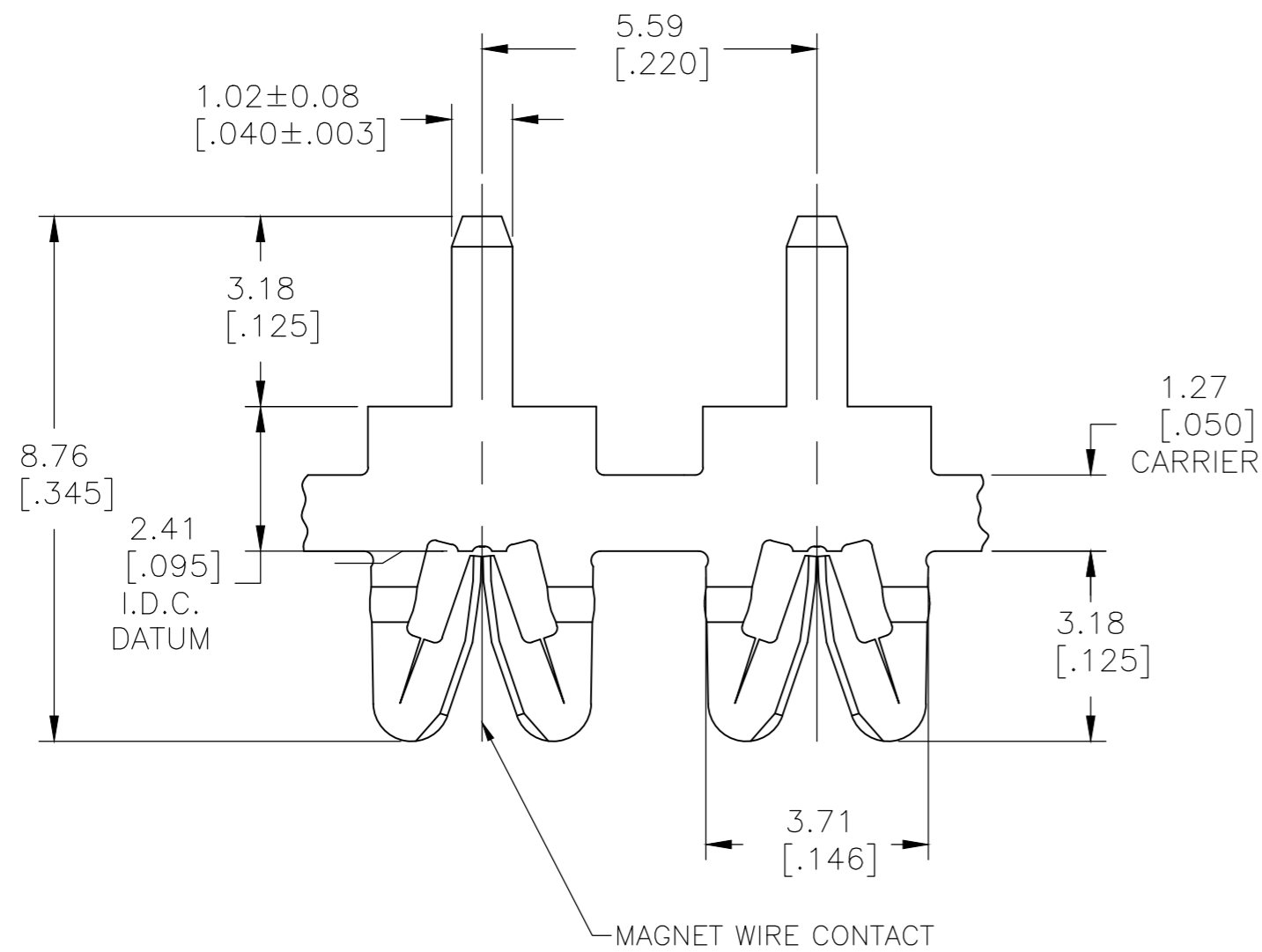
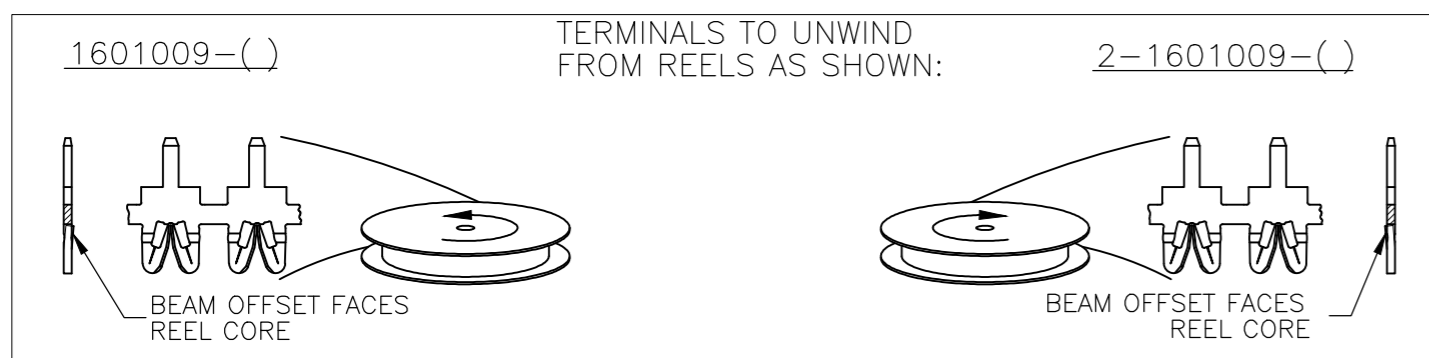
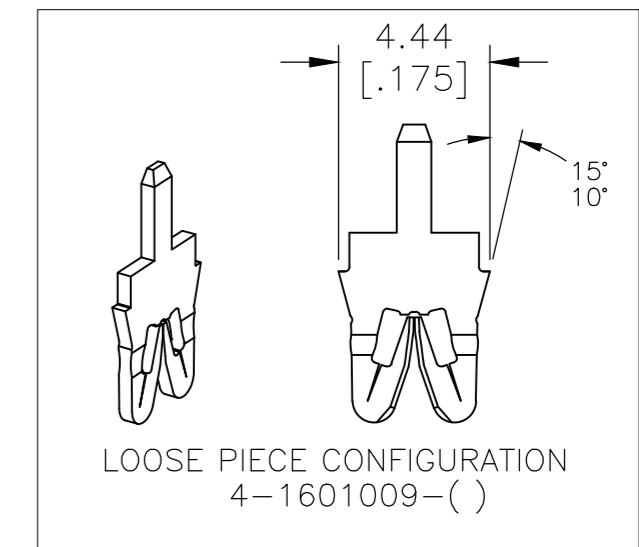

EXTRA HARD CU ALLOY	UNPLATED	-	4-1601009-5	5
EXTRA HARD CU ALLOY	UNPLATED	-	1601009-5	5
BRASS,SPRING HARD	POST TIN PLATE OVER NICKEL	-	4-1601009-4	
BRASS,SPRING HARD	POST TIN PLATE OVER NICKEL	-	1601009-4	
OBSELETE	BRASS,SPRING HARD	SELECTIVE POST TIN-LEAD PLATE OVER NICKEL	031-020-124	4-1601009-3
SUPERSEDED BY 4-1601009-4	BRASS,SPRING HARD	POST TIN-LEAD PLATE OVER NICKEL	031-020-024	4-1601009-2
SUPERSEDED BY 1601009-4	BRASS,SPRING HARD	POST TIN-LEAD PLATE OVER NICKEL	131-020-024	1601009-2
	BRASS,SPRING HARD	UNPLATED	131-020-000	1601009-1
MATERIAL	FINISH	REFERENCE PART NUMBER	TE PART NUMBER	

THIS DRAWING IS A CONTROLLED DOCUMENT.

DIMENSIONS: mm [INCHES]

TOLERANCES UNLESS OTHERWISE SPECIFIED:

0 PLC	± -
1 PLC	± -
2 PLC	± 0.13[.005]
3 PLC	± -
4 PLC	± -
ANGLES	± 2°

MATERIAL: SEE TABLE      FINISH: SEE TABLE

APPROVALS:

DWN	J.WELLER	11JAN2002
CHK	M.FEHER	11JAN2002
APVD	K.RANDOLPH	11JAN2002

PRODUCT SPEC: 108-2085

APPLICATION SPEC: 3

TE Connectivity

STANDARD RANGE WIRE TO 1.01 X 0.51 P.C.B. SIAMEZE TERMINAL

SIZE: A2      CAGE CODE: 00779      DRAWING NO: C=1601009      RESTRICTED TO: -

WEIGHT: 0      SCALE: 9:1      SHEET: 1 OF 1      REV: E6

CUSTOMER DRAWING