

REV	DESCRIPTION, ECN, EAR NO.	DATE	APP'D
A	PROPOSAL DRAWING	MAY16/19	L.CHAN
B	PROPOSAL DRAWING	MAY20/19	L.CHAN
C	PROPOSAL DRAWING	DEC10/19	L.CHAN
D	ADD PACKAGING INFORMATION	DEC11/19	L.CHAN
E	ADD PACKAGING SHEET	DEC13/19	L.CHAN

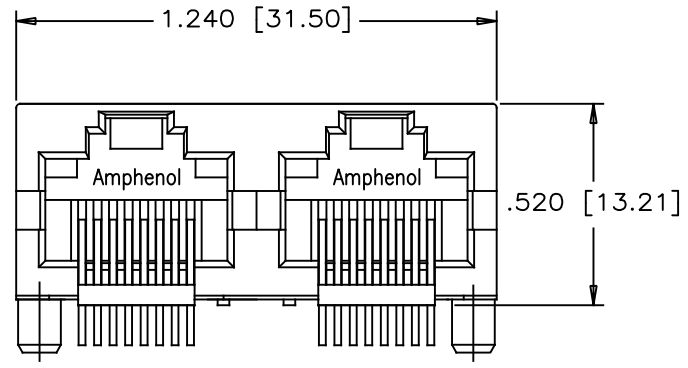

FRONT VIEW

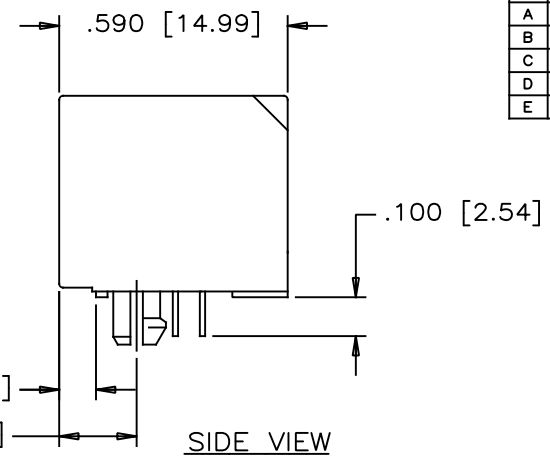

SIDE VIEW

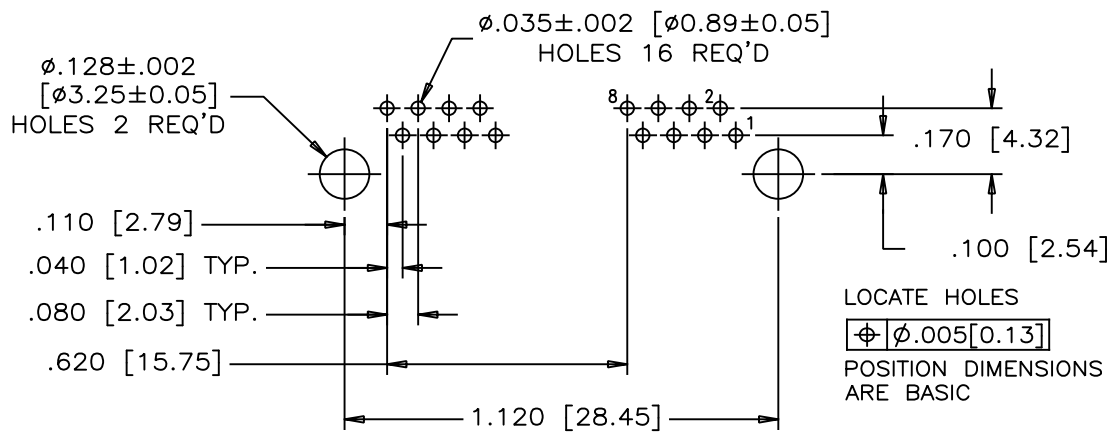

RECOMMENDED P.C.B. LAYOUT
(COMPONENT SIDE OF BOARD)

MATERIALS:

PLASTIC HOUSING: HIGH TEMPERATURE THERMOPLASTIC
FLAMMABILITY RATING UL 94V-0
COLOR: BLACK

CONTACTS:

PHOSPHOR BRONZE
PLATING: SELECTIVE GOLD PLATING ON MATING SURFACES
SEE AMPHENOL PART NUMBER FOR DETAIL.
50 μ" [1.27 MICRONS]
MIN. NICKEL UNDERPLATE
100 μ" [2.54 MICRONS]
MIN. MATTE TIN ON CONTACT TAILS.

PACKAGING: TUBE PACKAGING

PART NUMBER: RJHSE-X080-02

GOLD PLATING

E=RJ45 FLAT CONTACT 6u"
G=RJ45 FLAT CONTACT 15u"
J=RJ45 FLAT CONTACT 30u"
5=RJ45 FLAT CONTACT 50u"

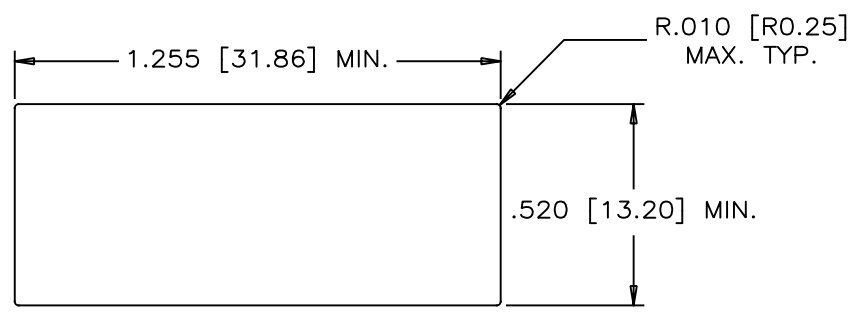

RECOMMENDED PANEL CUTOUT

UNLESS SPECIFIED OTHERWISE	DRAWN HANSON.C	MAY16/19	Amphenol Canada Corp. Commercial Products
PRIMARY UNITS INCHES	CHECKED L.CHAN	MAY16/19	
SECONDARY MILLIMETERS	M.E. APP'D		
REFERENCE IN PARENTHESES	Q.A. APP'D		
GENERAL TOLERANCES		DWG APP'D	2 PORT HIGH SPEED MODULAR JACK, 8P8C, WITHOUT LEADS, UNSHIELDED, TUBE PACKAGING- RoHS COMPLIANT
1 DECIMAL PLACE	±0.025	ENG. REL. NO.	
2 DECIMAL PLACES	±0.02		
3 DECIMAL PLACES	±0.015	REF.	DWG NO. RJHSE-X080-02
ANGULAR DEGREES	±1°	THIRD ANGLE PROJECTION	REV E
		DO NOT SCALE DRAWING	CODE ID NO. 03554 DWG SIZE C SCALE NA SHEET 1 OF 2

REV	DESCRIPTION, ECN, EAR NO.	DATE	APP'D
A	PROPOSAL DRAWING	MAY16/19	L.CHAN
B	PROPOSAL DRAWING	MAY20/19	L.CHAN
C	PROPOSAL DRAWING	DEC10/19	L.CHAN
D	ADD PACKAGING INFORMATION	DEC11/19	L.CHAN
E	ADD PACKAGING SHEET	DEC13/19	L.CHAN

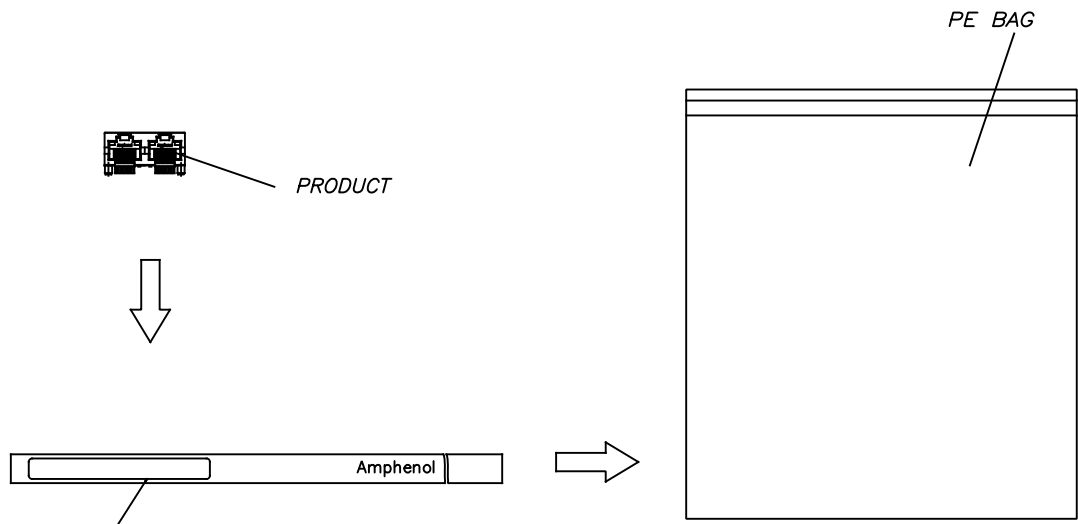

APPLY LABEL P/N FRJ-2690-41 AT LEFT END OF TUBE.

FIGURE 1

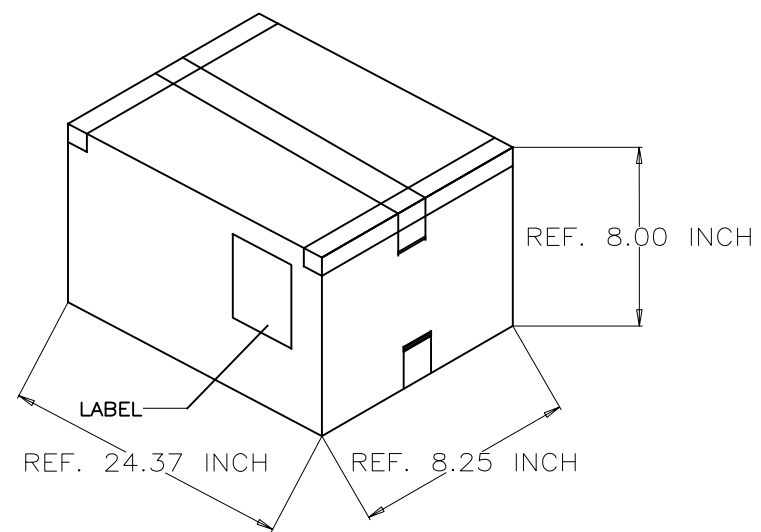

NOTES: (FOR TUBE PACKAGING)

1. ASSEMBLE 18PCS CONNECTORS INTO TUBES AS SHOWN IN FIGURE 1.
2. PLUG THE ENDS OF THE TUBES AND APPLY LABEL TO THE TUBE.
3. FULLY LOADED CARTONS WILL CONTAIN 81 TUBES.
4. MARK CARTON WITH PART NUMBER AND QUANTITY. NOTE THAT SHIPPING INSTRUCTIONS WILL INDICATE THE NEED FOR ADDITIONAL TUBE OR CARTON BAR CODED LABEL INFORMATION.
5. PUT THE FINISH TUBES AND DESICCANT INTO A PE BAG, THEN PUT INTO CARTON.

THIS DOCUMENT CONTAINS PROPRIETARY INFORMATION AND SUCH INFORMATION MAY NOT BE DISCLOSED TO OTHERS FOR ANY PURPOSE OR USED FOR MANUFACTURING PURPOSES WITHOUT WRITTEN PERMISSION FROM AMPHENOL CANADA CORP.

UNLESS SPECIFIED OTHERWISE	DRAWN HANSON.C	MAY16/19	Amphenol Canada Corp. Commercial Products
PRIMARY UNITS INCHES	CHECKED L.CHAN	MAY16/19	
SECONDARY MILLIMETERS	M.E. APP'D		2 PORT HIGH SPEED MODULAR JACK, 8P8C, WITHOUT LEADS, UNSHIELDED, TUBE PACKAGING- RoHS COMPLIANT
REFERENCE IN PARENTHESES	Q.A. APP'D		
GENERAL TOLERANCES	DWG APP'D		
1 DECIMAL PLACE ±0.025	ENG. REL. NO.		DWG NO. RJHSE-X080-02
2 DECIMAL PLACES ±0.02	REF.		
3 DECIMAL PLACES ±0.015	THIRD ANGLE PROJECTION	DO NOT SCALE DRAWING	REV E
ANGULAR DEGREES ±1°			CODE ID NO. 03554 DWG SIZE C SCALE NA SHEET 2 OF 2