

# EMV 1025S-0 1

## Single Hole Mounting Meter

EMV 1025S-0 1 is an easy to mount LCD digital voltmeter. It features 200mV full scale reading, auto-zero and auto-polarity. Installation time is greatly reduced with only 3 wires to connect. The user need only drill a single 5.5mm /  $\frac{7}{32}$ " hole in the panel. The module is fitted to the panel by locating its screw threaded stud through the hole, adding the washer and tightening the nut provided. The module's connections pass through the hollow stud into the target application. A rubber seal is included, providing splashproof protection for the unit when fitted to the meter during installation.

This datasheet also refers to OEM variants, referred to as EMV 1025S-XX X, where XX refers to the factory-configured scaling and decimal configuration options.

- 🔌 Single Hole Mounting
- 🔌 12.5mm / 0.5" LCD Digit Height
- 🔌 200mV Full Scale Reading
- 🔌 3-Wire Connection
- 🔌 Auto-zero, Auto-polarity
- 🔌 Low Battery Warning
- 🔌 Splashproof



Stock Numbers*	
EMV 1025S-X X	
Range	Decimal Point
0=200mV	0=NO DP
1=2V	1=DP1
2=20V	2=DP2
3=200V**	3=DP3

e.g.: EMV 1025S-1 3 2Vd.c. full scale, DP3 displayed (1.999)

For modules manufactured to your scaling requirements, contact Lascar direct.\*

\* Minimum order quantity of 50 pcs. applies.

\*\* Maximum allowable input voltage is 60Vd.c.

Specifications	Min.	Typ.	Max.	Unit
Accuracy (overall error)*		0.1		% ( $\pm 2$ counts)
Linearity			$\pm 1$	count
Displayed reading	-1999		1999	
Resolution		0.1		mV d.c.
Sample rate		3		sample/sec
Operating temperature range	0		50	$^{\circ}\text{C}$
Temperature stability <sup>1</sup>		100		ppm/ $^{\circ}\text{C}$
Supply voltage	3.5	5	7.0	V d.c.
Supply current		250		$\mu\text{A}$

\* To ensure maximum accuracy, recalibrate periodically.

Unless otherwise noted, specifications apply at  $T_A=25^{\circ}\text{C}$ ,  $V_{\text{supply}}=5\text{Vd.c.}$  ( $f_{\text{clock}}=48\text{kHz}$ ) and are tested with the module configured for fully floating input mode.

### DIMENSIONS All dimensions in mm (inches)

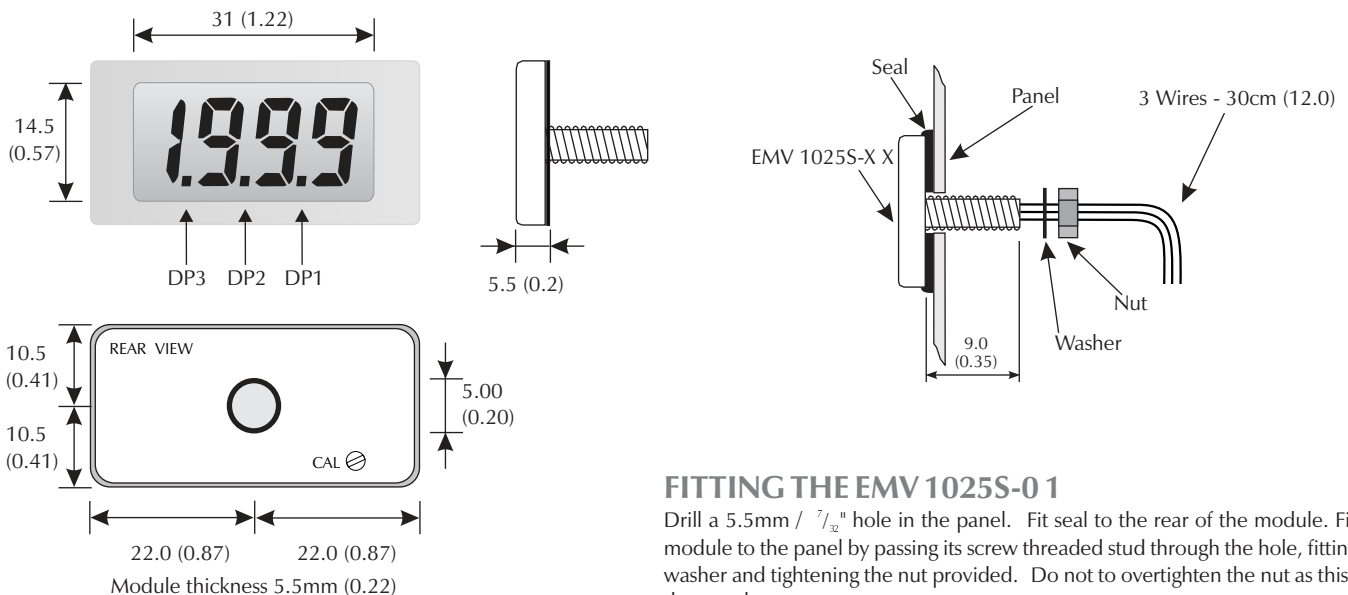

## TERMINAL FUNCTIONS

1. Red V+ Positive power supply connection.
2. Black GND Negative power supply connection.
3. Yellow IN HI Positive measuring input with reference to GND.

## SAFETY

To comply with the Low Voltage Directive (LVD 93/68/EEC), input voltages to the module's pins must not exceed 60Vdc. The user must ensure that the incorporation of the unit into the user's equipment conforms to the relevant sections of BS EN 61010 (Safety Requirements for Electrical Equipment for Measuring, Control and Laboratory Use).

## VOLTAGE SCALING

Two resistors Ra and Rb may be added in order to alter the full scale reading (FSR) of the meter - see table and diagrams below. The meter may be re-calibrated by adjusting the calibration potentiometer at the rear of the module.

Required $V_{FSR}$	Ra	Rb
2V*	910k $\Omega$	100k $\Omega$
20V*	1M $\Omega$	10k $\Omega$
200V*	1M $\Omega$	1k $\Omega$

\* Subject to a minimum order quantity of 50 pcs., pre-scaled modules are available from Lascar. See stock number table on the front of this datasheet. Customer-specific scaling options may also be available on request. Contact Lascar sales office for details.

## CURRENT SCALING

A current shunt Rs may be added in order to alter the full scale reading (FSR) of the meter - see table and diagrams below. The meter may be re-calibrated by adjusting the calibration potentiometer at the rear of the module.

Required $I_{FSR}$	Rs	P (Power Rating)
200uA	1k $\Omega$	0.04mW
2mA	100 $\Omega$	0.4mW
20mA	10 $\Omega$	4mW
200mA	1 $\Omega$	40mW
2A	100m $\Omega$ **	400mW
20A	10m $\Omega$ **	4W
200A	1m $\Omega$	40W

\*\* We recommend that purpose made shunts are used for these ranges.

## APPLICATIONS

Do not connect more than one meter to the same power supply if the meters cannot use the same signal ground. Do not connect IN HI to a voltage greater than (V+ - 1V) or to a voltage lower than -(V+) + 1V if the meter is unscaled, as this may damage the meter. Keep leads short to ensure noise-free operation. To maximise measurement accuracy, use high precision (1%), low temperature drift (50ppm/ $^{\circ}$ C or better) scaling resistors (Ra, Rb and Rs).

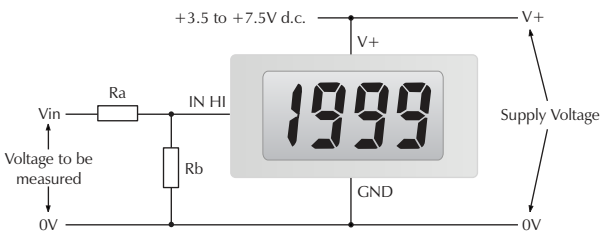

Measuring a single ended input referenced to supply.

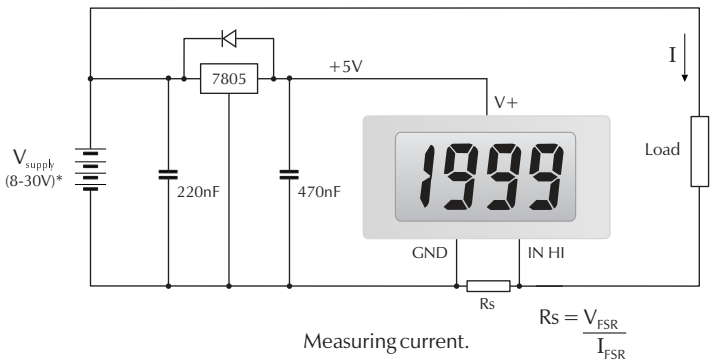

Measuring current.

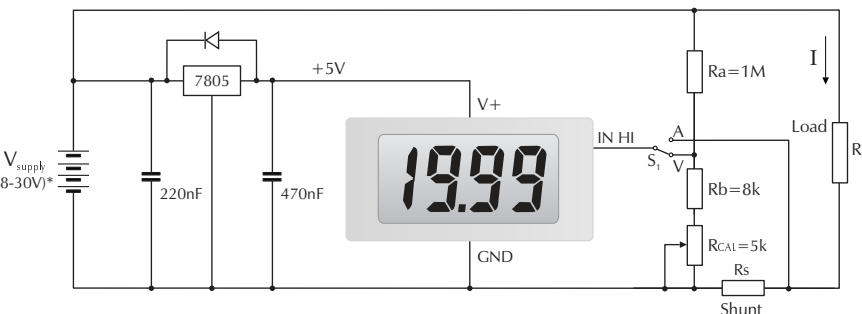

Measuring supply voltage and current.

The module shown is an EMV 1025S-0 2

S<sub>1</sub> selects between voltage and current measurement

Voltage: Ra, Rb and Rcal scale the module for 20V<sub>FSR</sub>

Current:  $R_s = \frac{200mV}{I_{FSR}}$  (e.g. 10m $\Omega$  / 4W for I<sub>FSR</sub>=20A)

Calibration:

First calibrate the current range, by adjusting the meter's own calibration potentiometer. Then calibrate the voltage range, by adjusting the Rcal potentiometer.

\* Consult 7805 voltage regulator manufacturer's datasheet for minimum and maximum allowable input voltage ratings.