

Tous droits strictement réservés. Reproduction ou communication à des tiers interdite sous quelque forme que ce soit sans autorisation écrite du propriétaire. Propriété de FCI. Droits de reproduction FCI.

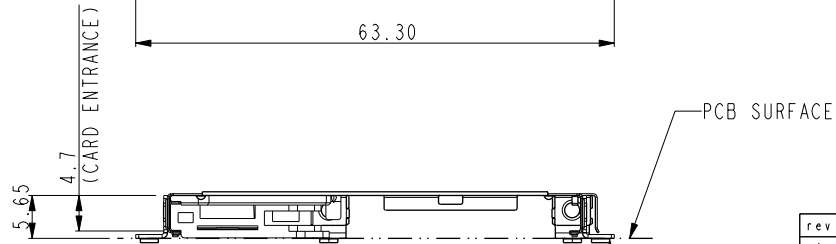

All rights strictly reserved. Reproduction or issue to third parties in any form whatever is not permitted without written authority from the proprietor. Property of FCI. Copyright FCI.

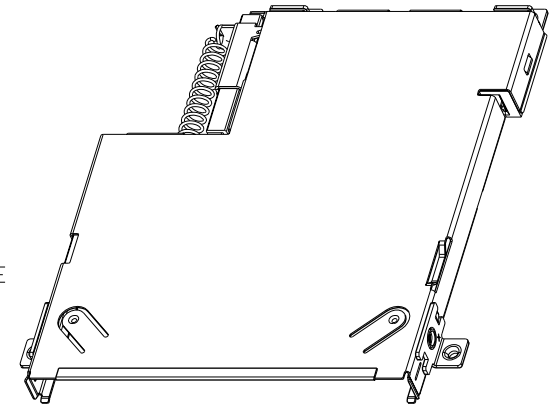
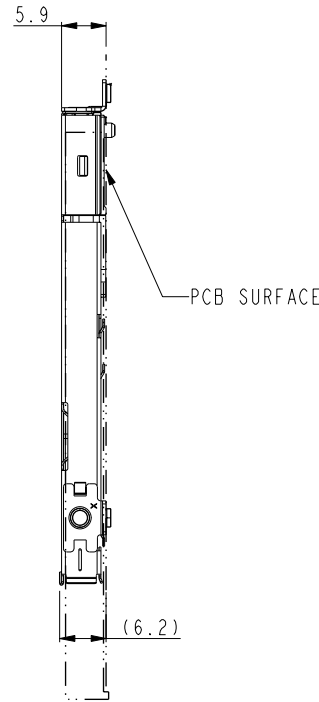
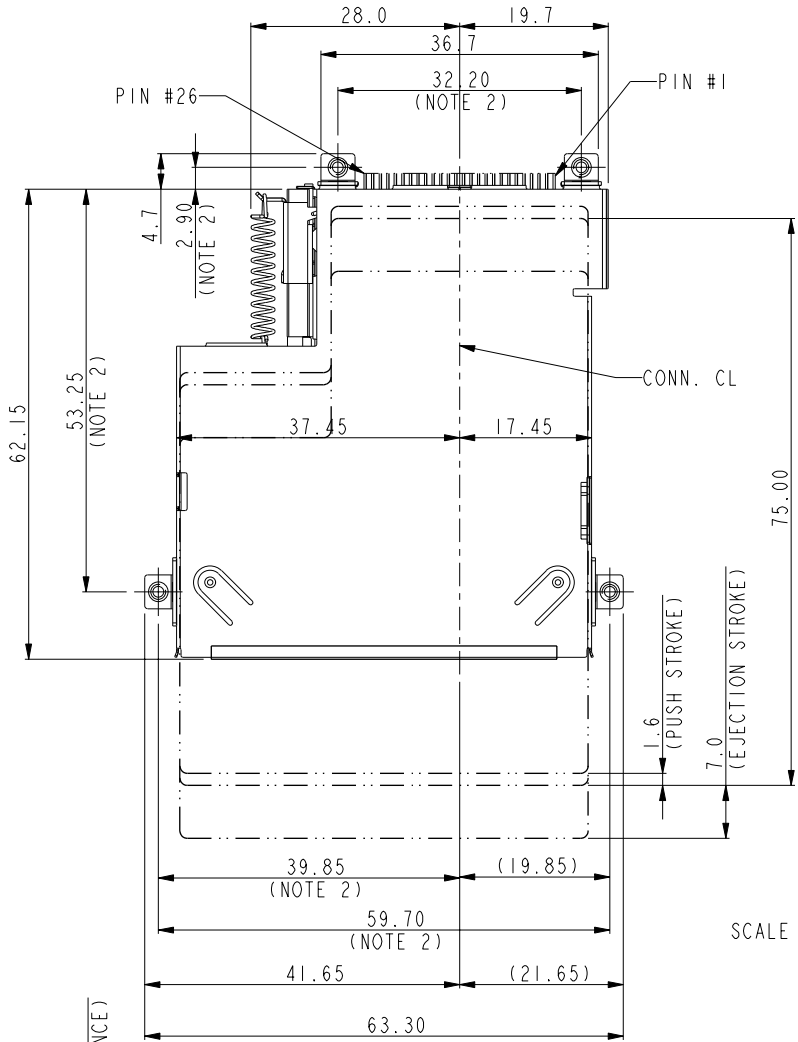

rev	ecn no	dr	date
A	T05-0186	TAI	08/31/05
B	T05-0244	TAI	11/02/05
-	-	-	-
-	-	-	-
-	-	-	-
-	-	-	-

		www.fciconnect.com	tolerance ASME Y14.5	projection	MM
Dr	KENNY TAI	04/07/05	Product family	size	A4
Eng	KENNY TAI	04/07/05	Spec ref	Scale	1.000
Chr	KENNY TAI	04/07/05	Material	ECN	T05-0244
Appr	PAUL WANG	04/07/05	SEE NOTES		
title			BELOW MOUNT, 0 S/O		Rev. B
EXPRESSCARD HOST MECH.					
catalog no			10055263	CUSTOMER	sheet 1 of 2

tolerance unless otherwise specified	
linear	.X ± .5
	.XX ± .30
angles	0° ± 2°

1

2

3

4

PART NO.	MOUNTING	STAND-OFF	HOST CONN P/N	PRODUCT SPEC.	PACKING SPEC.
I0055263-00BLF	BELOW	0MM	I0055262-X00BXXLF	GS-12-301	GS-14-295

Tous droits strictement reserves. Reproduction ou communication a des tiers interdite sous quelque forme que ce soit sans autorisation ecrite du proprietaire. Propriete de c FCI. Droits de reproduction FCI.



All rights strictly reserved. Reproduction or issue to third parties in any form whatever is not permitted without written authority from the proprietor. Property of FCI. Copyright FCI.

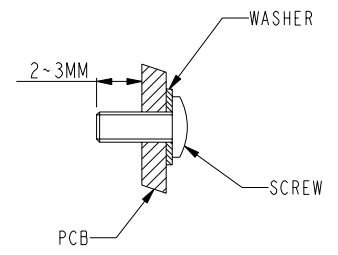
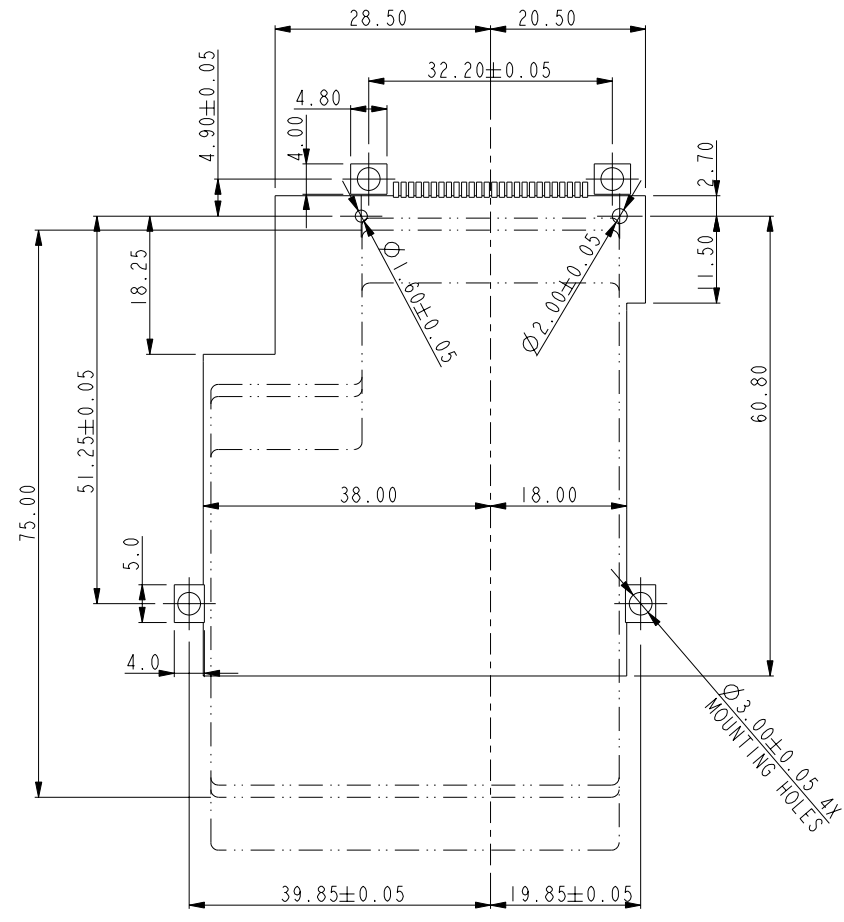

DETAIL 2
RECOMMENDED SCREW LENGTH

NO MOUNTING PART AREA

- NOTE:
- 4 M2*0.4P SCREWS WITH WASHER ARE REQUIRED.
 - SHOW DIMENSION AFTER FASTENED TO PCB.
 - SEE HOST CONNECTOR DRAWINGS FOR PCB LAYOUT DETAIL.
 - RECOMMENDED TIGHTING TORQUE 1.6~1.8 KGF-CM.
 - SEE DETAIL 2 FOR RECOMMENDED SCREW LENGTH.

RECOMMENDED PCB LAYOUT
VIEW FROM MOUNTING SIDE
SCALE 1.000

title	BELOW MOUNT, 0 S/O EXPRESSCARD HOST MECH.	dwg no	I0055263	Rev.	B
catalog no	I0055263	CUSTOMER	sheet 2 of 2		